



Model : 45/2023



Su-57 Felon / T-50 PAK FA

1000mm

Specs :

1. Wingspan 1000mm / 39.37 inches
2. Flying weight : 1028 grams/ 36.3 oz
3. Wing loading : 20.4 gram/dm² - 6.7 oz/sq.ft.
4. Wing cube loading : 2.9
5. Wing Area : 50.35 dm² / 780 sq.in.
6. CG : 8 cm / 5.39 inch from Wing Break

Electronics for test (pusher prop)

- DXW 3536 1200kv
- Prop 10x6 (2 blades)
- 50A ESC
- Battery Lipo 4S 2200mah
- 4 x 9 gram servos (micro servo)

Electronics for test (EDF)

- FMS 70mm 12 blades 6S EDF
- 80A Predator ESC
- Battery Lipo 3S 2200mah x2 (series connection)
- 4 x 9 gram servos (micro servo)

Transmitter

- Jumper T16 + BetaFPV Express LRS TX module
- 10 ch BetaFPV Express LRS RX

Materials :

1. 5mm Foamboard/ Depron/ Polyfoam
2. 10mm Carbon Tube/ Bamboo/ Wood Dowel 1 meter
3. 0.3mm Mica Plastic
4. hot glue, UHU glue, CA glue, PVA glue
5. Packing tapes

Build Instructions :

1. paper-replika.com
2. youtube channel : Julius Perdana

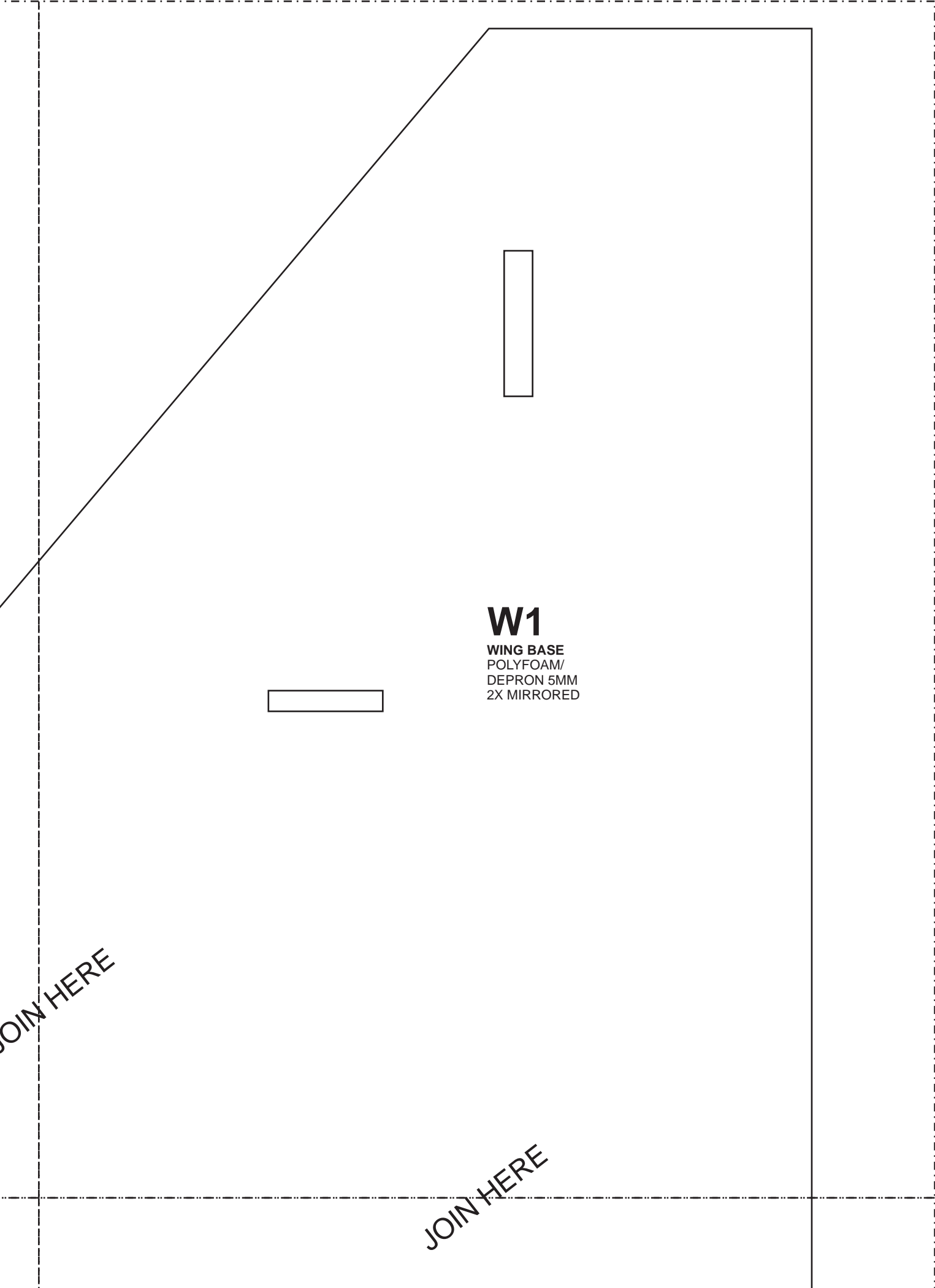

W1

WING BASE
POLYFOAM/
DEPRON 5MM
2X MIRRORED

JOIN HERE

JOIN HERE

F1

FUSELAGE FORMER
POLYFOAM/
DEPRON 5MM

F2

FUSELAGE FORMER
POLYFOAM/
DEPRON 5MM

F5

FUSELAGE FORMER
POLYFOAM/
DEPRON 5MM

W1

JOIN HERE

JOIN HERE

JOIN HERE

JOIN HERE

JOIN HERE



JOIN HERE

W1

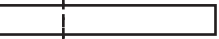

JOIN HERE

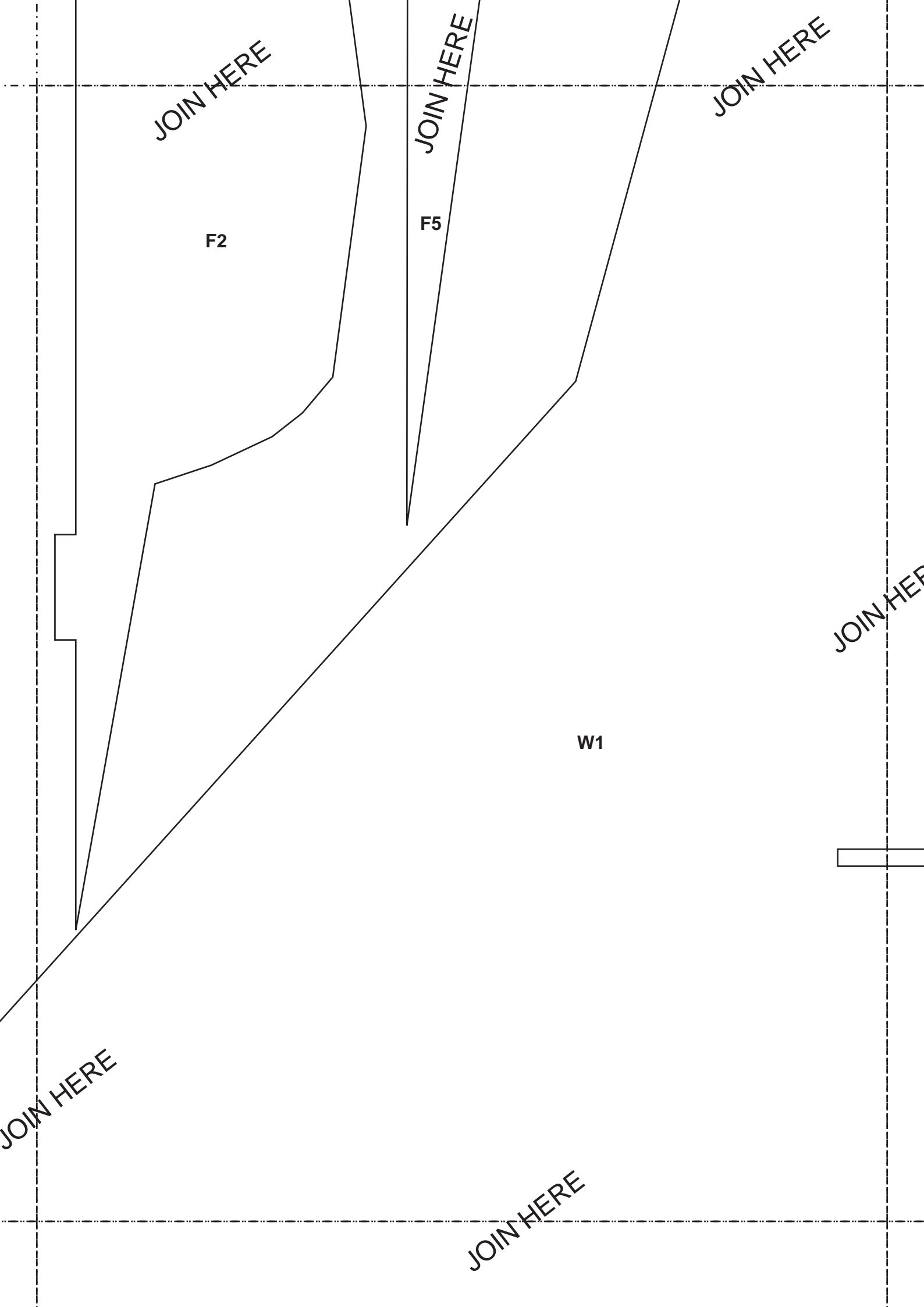

F11

NOSE
POLYFOAM/
DEPRON 5MM

S1

ELEVATOR
POLYFOAM/
DEPRON 5MM
2X MIRRORED

JOIN HERE

JOIN HERE

w1

JOIN HERE

JOIN HERE

W1



JOIN HERE

JOIN HERE

ERE



JOIN HERE

JOIN HERE

W1

JOIN HERE

JOIN HERE

JOIN HERE

F11

JOIN HERE

JOIN HERE

W1

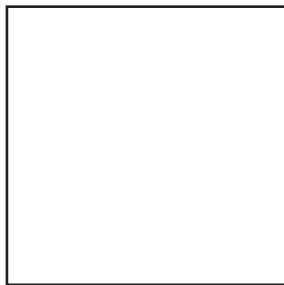

JOIN HERE

W1

JOIN HERE

JOIN HERE

W1

JOIN HERE

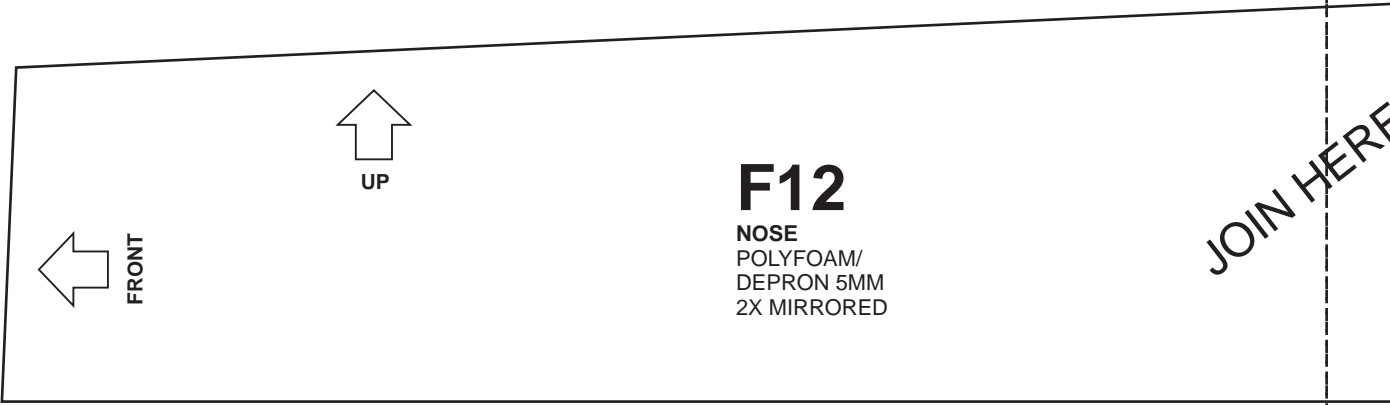

FRONT



UP

F12

NOSE
POLYFOAM/
DEPRON 5MM
2X MIRRORED

JOIN HERE

JOIN HERE

JOIN HERE

W1



F9A

FUSELAGE
POLYFOAM/
DEPRON 5MM

F12

JOIN HERE

JOIN HERE

JOIN HERE



W1

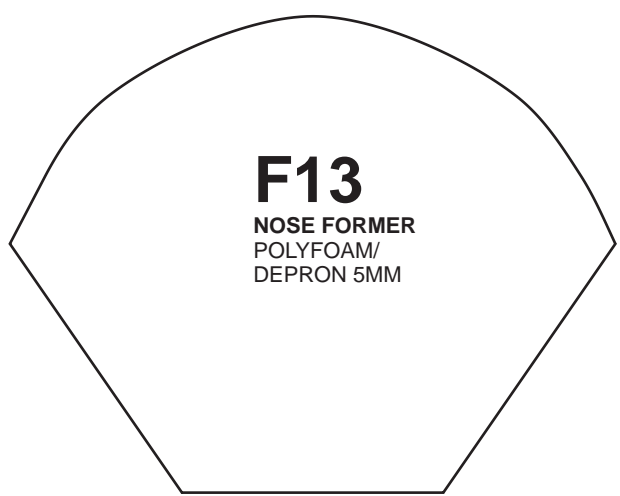

F13
NOSE FORMER
POLYFOAM/
DEPRON 5MM

F3

FUSELAGE
FORMER
POLYFOAM/
DEPRON 5MM

JOIN HERE

F4

FUSELAGE
FORMER
POLYFOAM/
DEPRON 5MM

JOIN HERE

F9

FUSELAGE
POLYFOAM/
DEPRON 5MM
2X MIRRORED

JOIN HERE

JOIN HERE

JOIN HERE

JOIN HERE

F4

F3

F9

F10

JOIN HERE

JOIN HERE

JOIN HERE

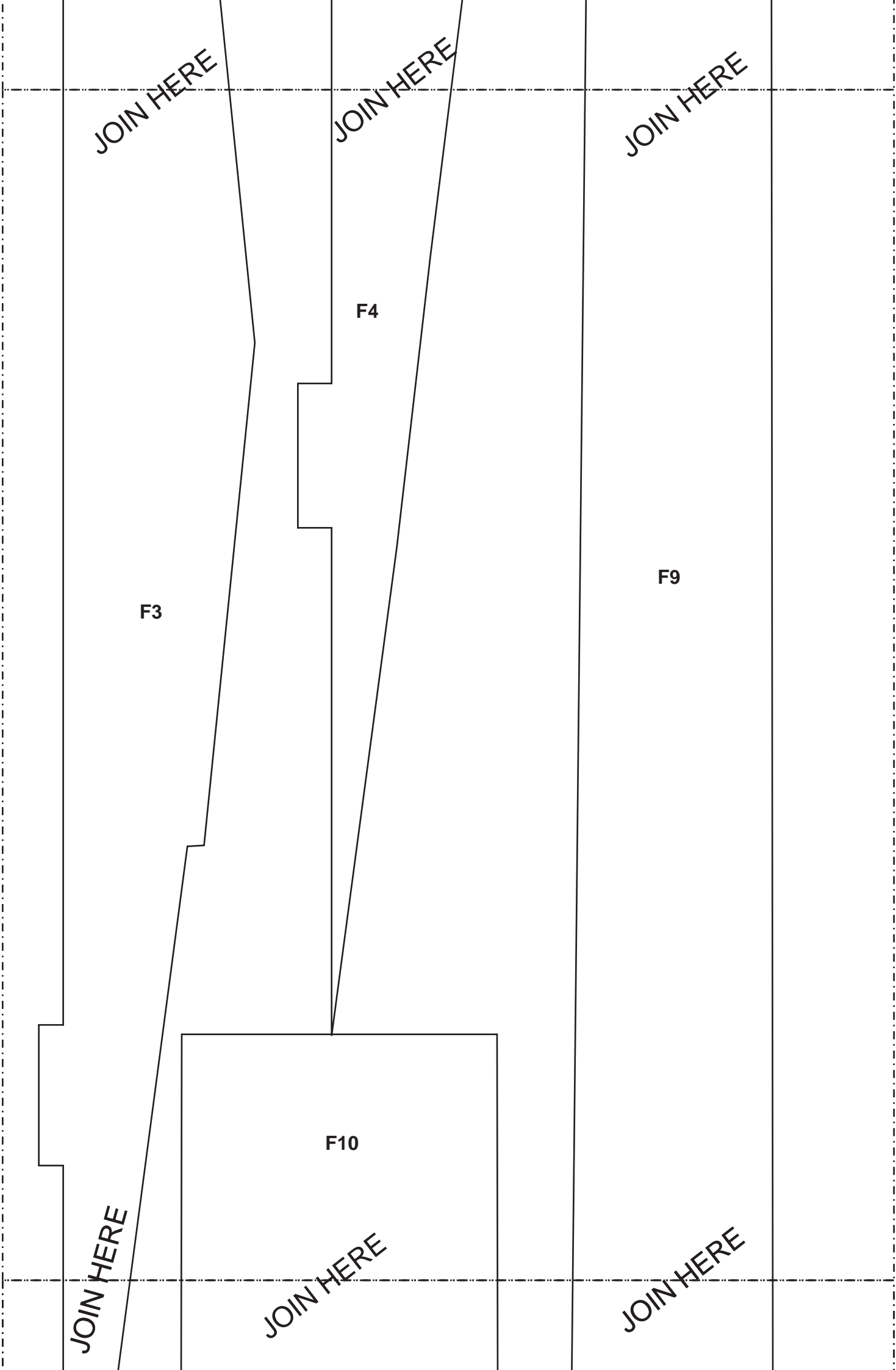

JOIN HERE

F6

JOIN HERE

JOIN HERE

F10

FUSELAGE
POLYFOAM/
DEPRON 5MM
2X MIRRORED

F9

JOIN HERE

JOIN HERE

JOIN HERE

JOIN HERE

F9

F10



FRONT

T2

TAIL
POLYFOAM/
DEPRON 5MM
2X MIRRORED



UP

JOIN HERE

JOIN HERE

JOIN HERE

JOIN HERE

T2

F10

FRONT





F6

FUSELAGE
POLYFOAM/
DEPRON 5MM

JOIN HERE

JOIN HERE

F6

JOIN HERE

JOIN HERE

F6

F7

FUSELAGE
POLYFOAM/
DEPRON 5MM

JOIN HERE

JOIN HERE

JOIN HERE

F7

JOIN HERE



F8
FUSELAGE
POLYFOAM/
DEPRON 5MM
2X MIRRORED

JOIN HERE

JOIN HERE

F7

JOIN H

A7

AIR INTAKE
POLYFOAM/
DEPRON 5MM
2X MIRRORED

JOIN HERE

JOIN HERE

JOIN HERE

F7

F8

F17

NOSE
POLYFOAM/
DEPRON 5MM

F18

NOSE
CARD/
0.2mm PLASTIC

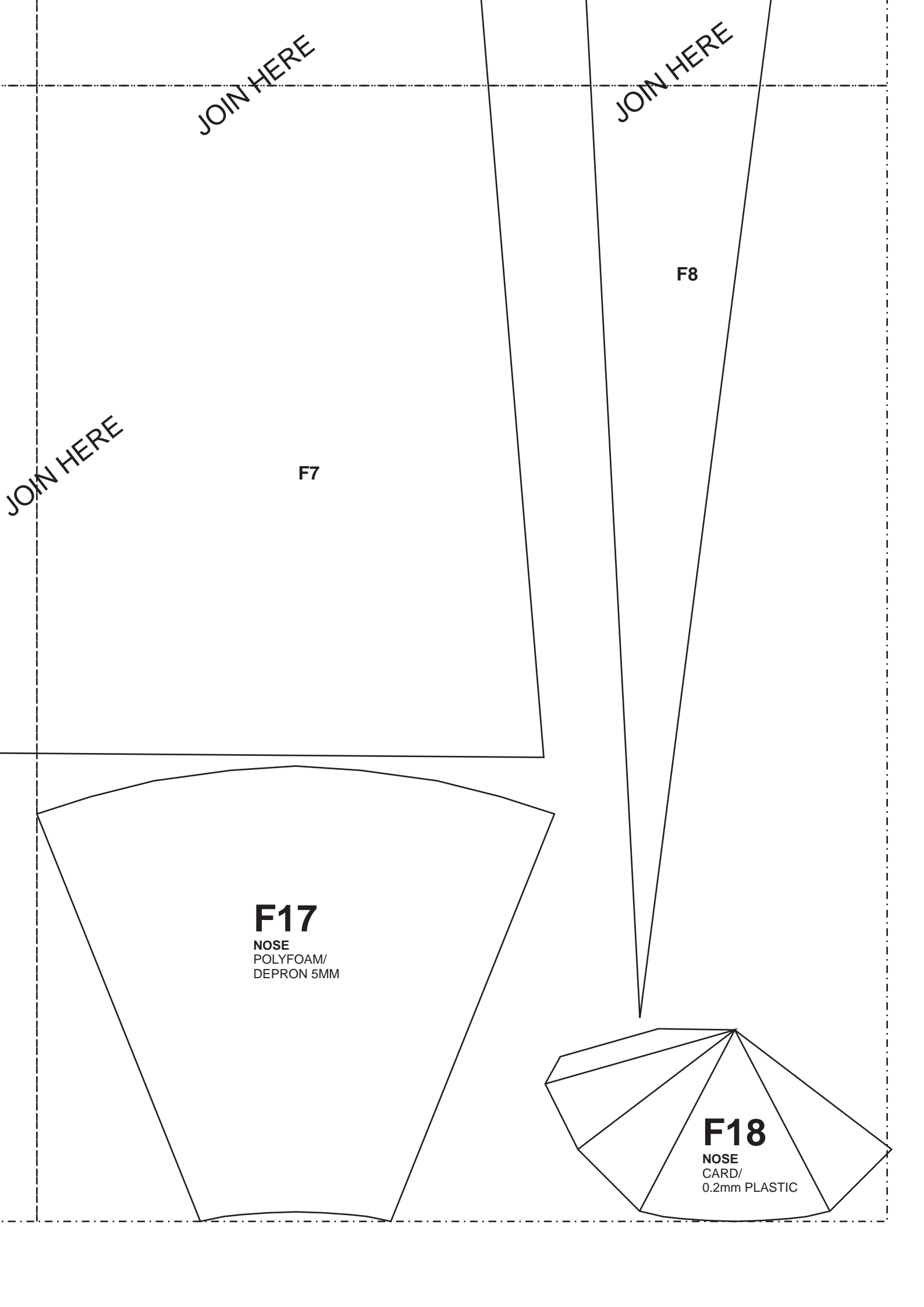

A3

AIR INTAKE
POLYFOAM/
DEPRON 5MM
2X MIRRORED

W2

WING
POLYFOAM/
DEPRON 3MM
2X MIRRORED

JOIN HERE

JOIN HERE

W2

JOIN HERE

JOIN HERE

W2



JOIN HERE

JOIN HERE

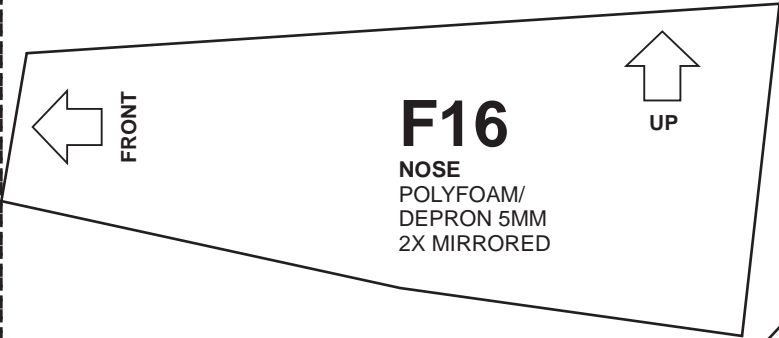

F16

NOSE
POLYFOAM/
DEPRON 5MM
2X MIRRORED

W2

W3

WING
POLYFOAM/
DEPRON 3MM
2X MIRRORED

F15

NOSE
POLYFOAM/
DEPRON 5MM

JOIN HERE

JOIN HERE

F14

W3

JOIN HERE

JOIN HERE

W3

JOIN HERE

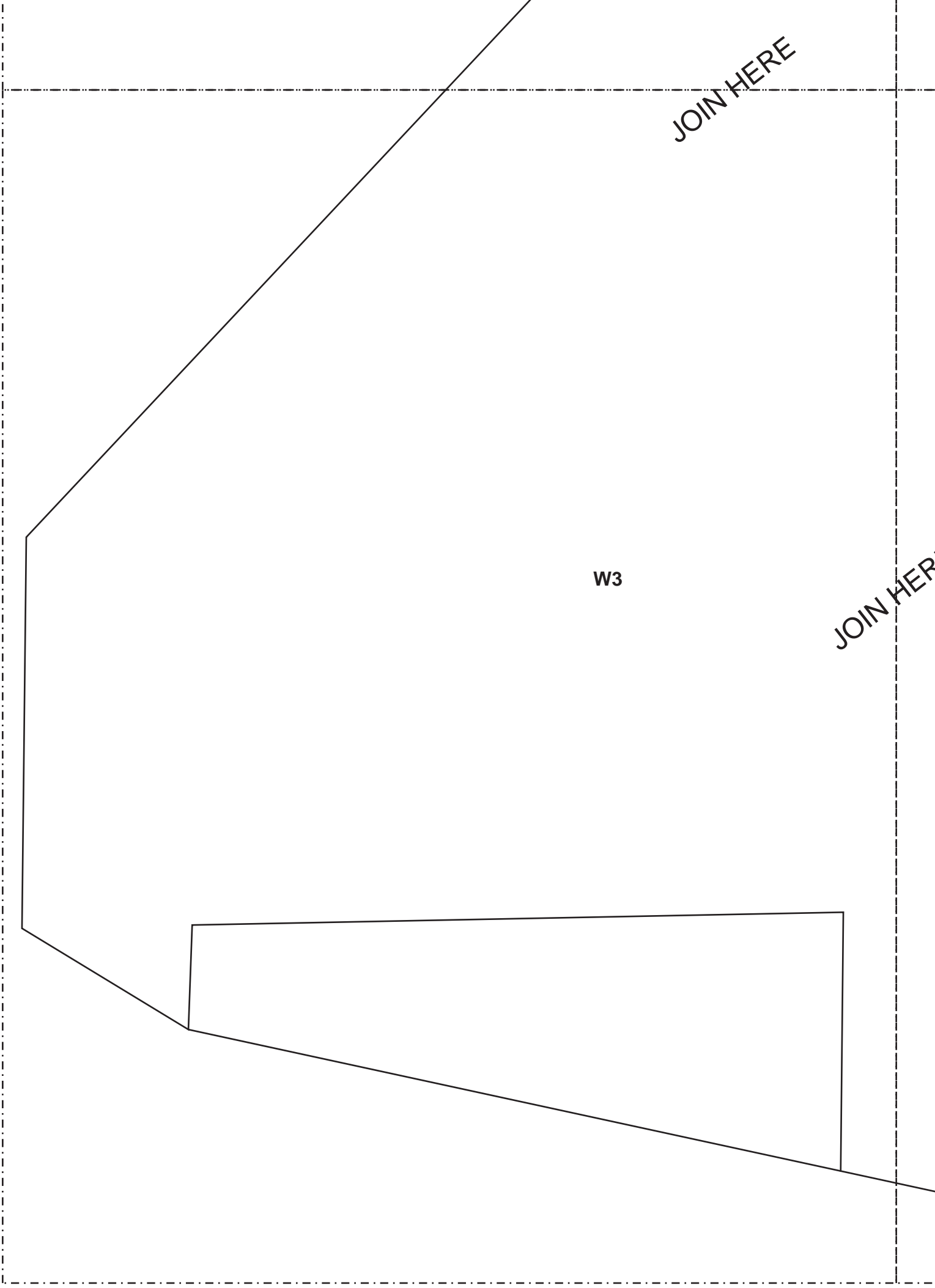

JOIN HERE

JOIN HERE

W3

A5

ENGINE
POLYFOAM/
DEPRON 5MM
2X MIRRORED

A6

ENGINE
POLYFOAM/
DEPRON 5MM
2X MIRRORED



F14

NOSE
POLYFOAM/
DEPRON 5MM

JOIN HERE

JOIN HERE

JOIN HERE

T3

5MM FOAM
T4
2X

F14

JOIN HERE

T1

ERE

T3

TAIL
POLYFOAM/
DEPRON 5MM

HERE

T1

TAIL
POLYFOAM/
DEPRON 5MM

A2

AIR INTAKE/ ENGINE
POLYFOAM/
DEPRON 5MM
2X MIRRORED

S4

VER-STAB
POLYFOAM/
DEPRON 5MM
2X MIRRORED

A1

AIR INTAKE/ ENGINE
POLYFOAM/
DEPRON 5MM
2X MIRRORED

JOIN HERE

JOIN HERE

JOIN HERE

JOIN HERE

JOIN HERE

JOIN HERE

S4

A2

A1

JOIN HERE

JOIN HERE

JOIN HERE

JOIN HERE

A2

A1

S1

VER-STAB
POLYFOAM/
DEPRON 5MM
2X

JOIN HERE

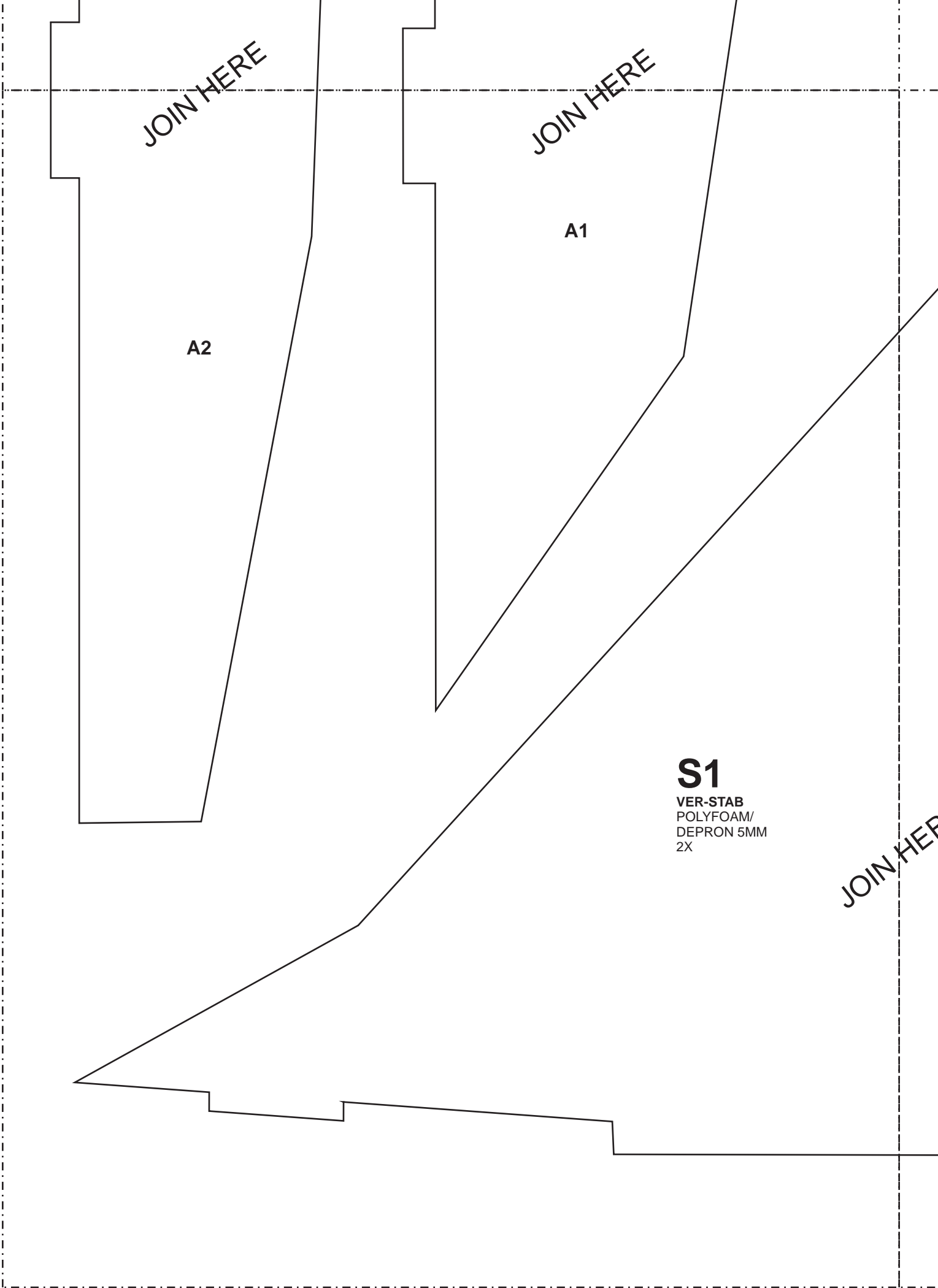

JOIN HERE

S1

S2

VER-STAB
POLYFOAM/
DEPRON 5MM
2X

S3

VER-STAB
POLYFOAM/
DEPRON 5MM
2X

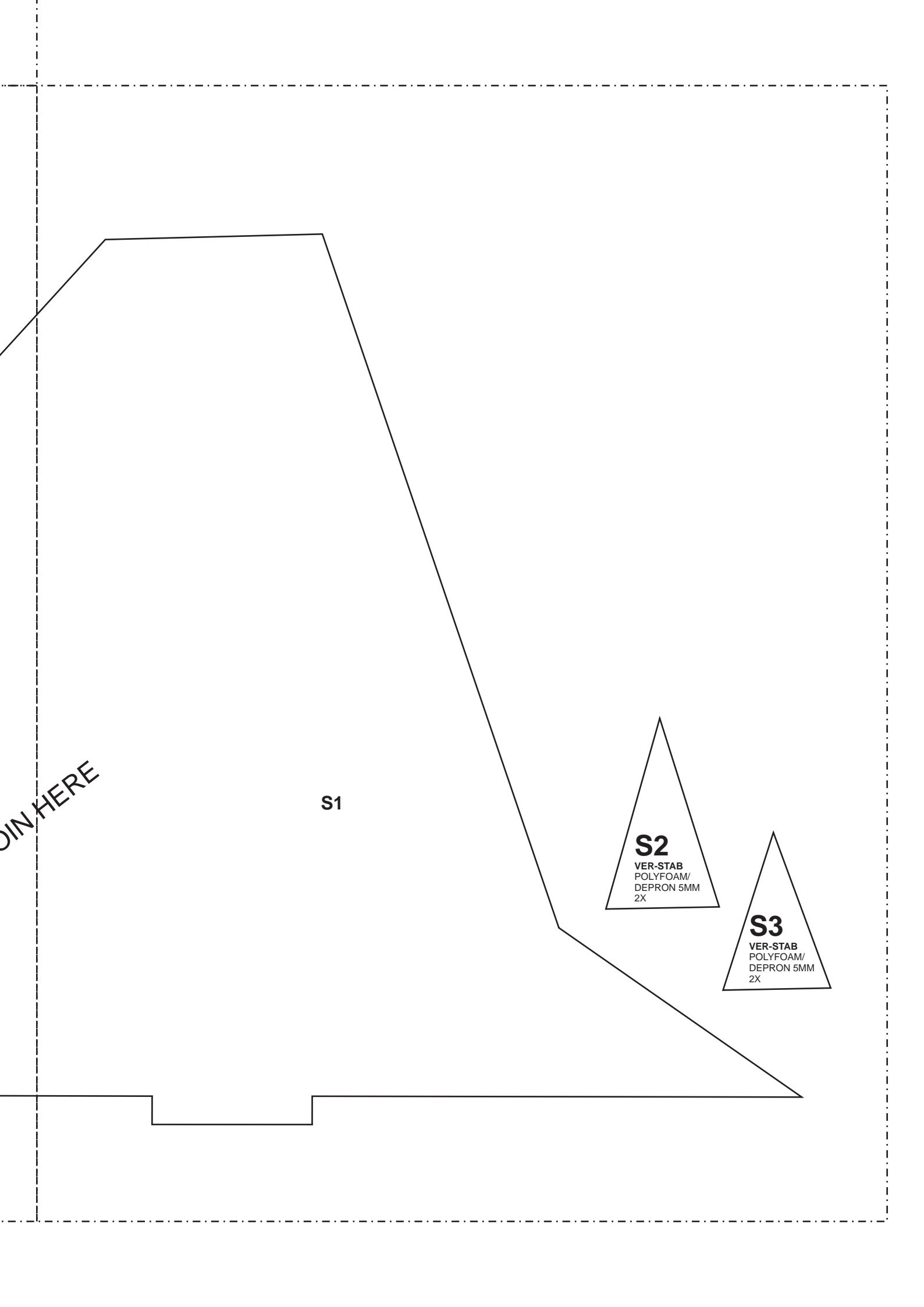

A4

AIR INTAKE/ ENGINE
POLYFOAM/
DEPRON 5MM
2X MIRRORED

E2

EXHAUST NOZZLE
POLYFOAM/
DEPRON 5MM
2X

JOIN HERE

E1

JOIN HERE

JOIN HERE

E1

JOIN HERE

A4

E1

EXHAUST NOZZLE
POLYFOAM/
DEPRON 5MM
2X

E3
ENGINE
POLYFOAM/
DEPRON 3MM
2X

C3
COCKPIT
POLYFOAM/
DEPRON 3MM /
CARDBOARD

C2
COCKPIT
POLYFOAM/
DEPRON 3MM /
CARDBOARD

C1
COCKPIT
POLYFOAM/
DEPRON 3MM /
CARDBOARD

JOIN HERE

JOIN HERE

E3

C2

CANOPY
MICA PLASTIC
0.3MM



FRONT

C1

CANOPY
MICA PLASTIC
0.3MM

C4

CANOPY
MICA PLASTIC
0.3MM

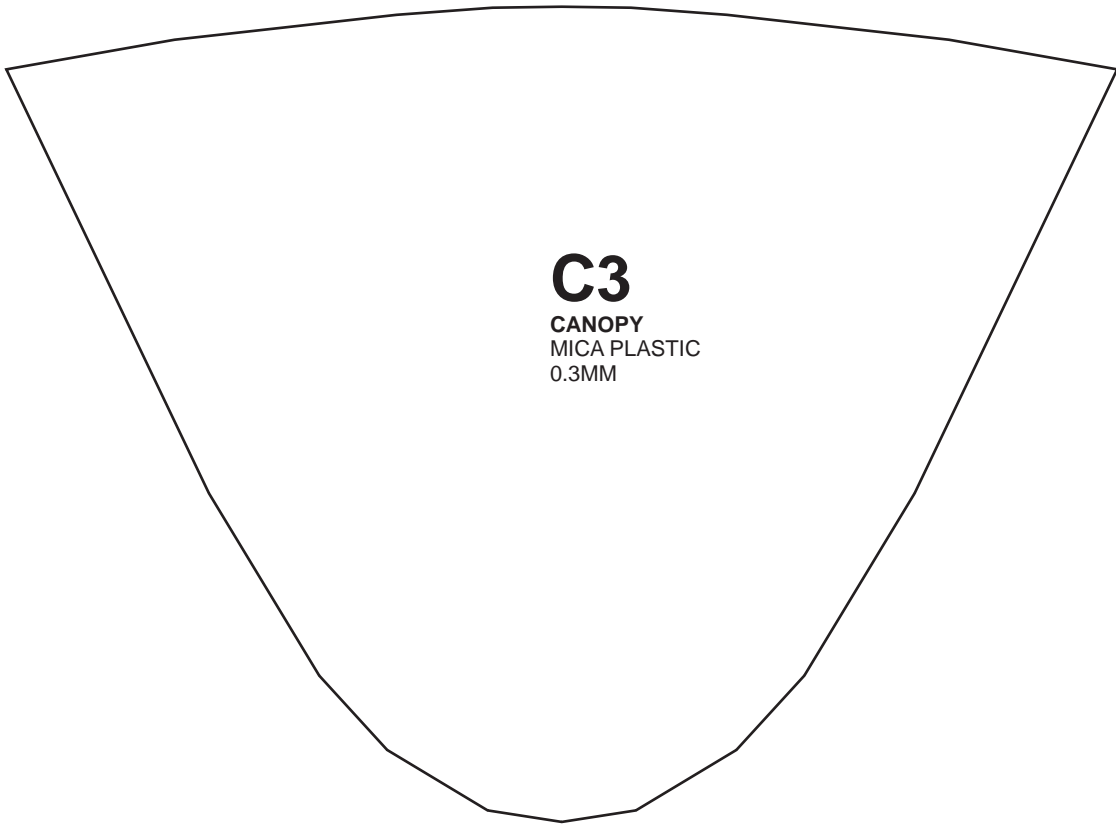

C3
CANOPY
MICA PLASTIC
0.3MM

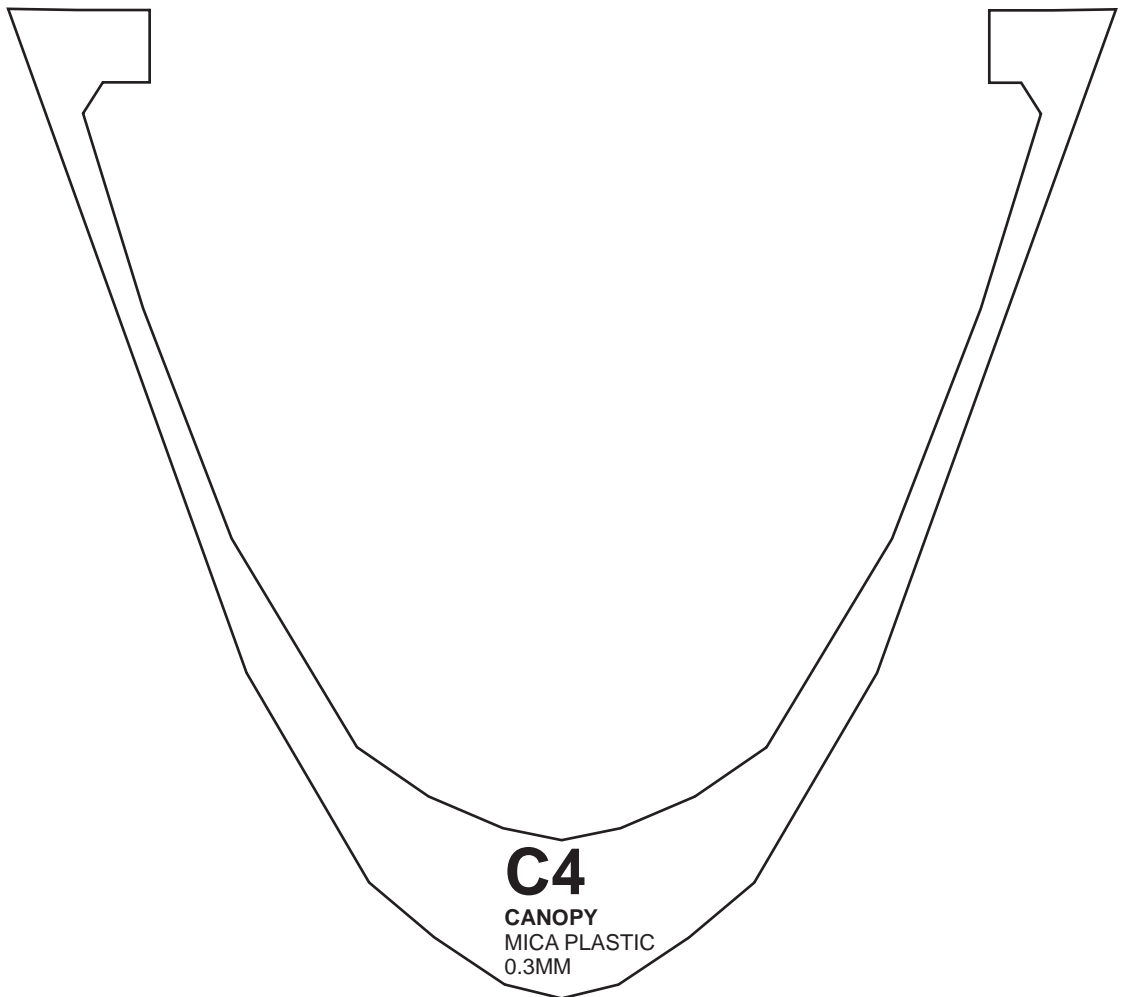

C4
CANOPY
MICA PLASTIC
0.3MM

G1
LG BASE
PLYWOOD
3MM

G1

G2

G1

G2

G2

D1
LG HATCH
PAPERCARD
2X

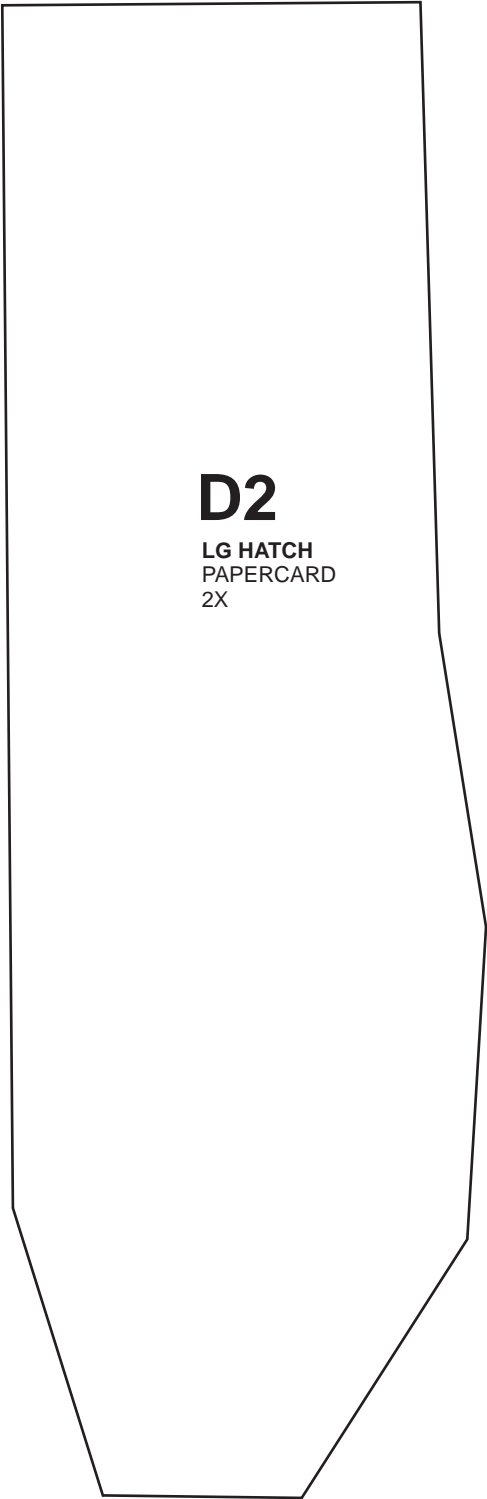

D2
LG HATCH
PAPERCARD
2X

