



Model : 58/2025



# F4U CORSAIR

**1300 mm**

## Specs :

1. Wingspan 1300 mm / 51 inches
2. Flying weight : 1588 grams/ 56 oz / 3.5 lbs
3. Wing loading : 47.3 gram/dm<sup>2</sup> - 15.5 oz/sq.ft.
4. Wing cube loading : 8.2 (Trainer-Aerobatic)
5. Wing Area : 33.56 dm<sup>2</sup> / 520 sq.in.
6. CG : 7 cm / 2.75 inch from leading edge

## Electronics for test

- DXW 3536 1200kv Brushless motor
- 50A ESC Hobbywing Skywalker
- Battery Lipo 4S 2200mah
- 5 x 9 gram servos (metal micro servo)

## Prop :

- 11x5x3 prop

## Transmitter

- Jumper T16 + BetaFPV Express LRS TX module
- 5 ch BetaFPV Express LRS RX

## Materials :

1. 5mm Foamboard/ Depron/ Polyfoam
2. 2mm Plywood
3. hot glue, UHU glue, CA glue
4. wax paper
5. PLA Filament

## Build Instructions :

1. [paper-replika.com](http://paper-replika.com)
2. youtube channel : Julius Perdana

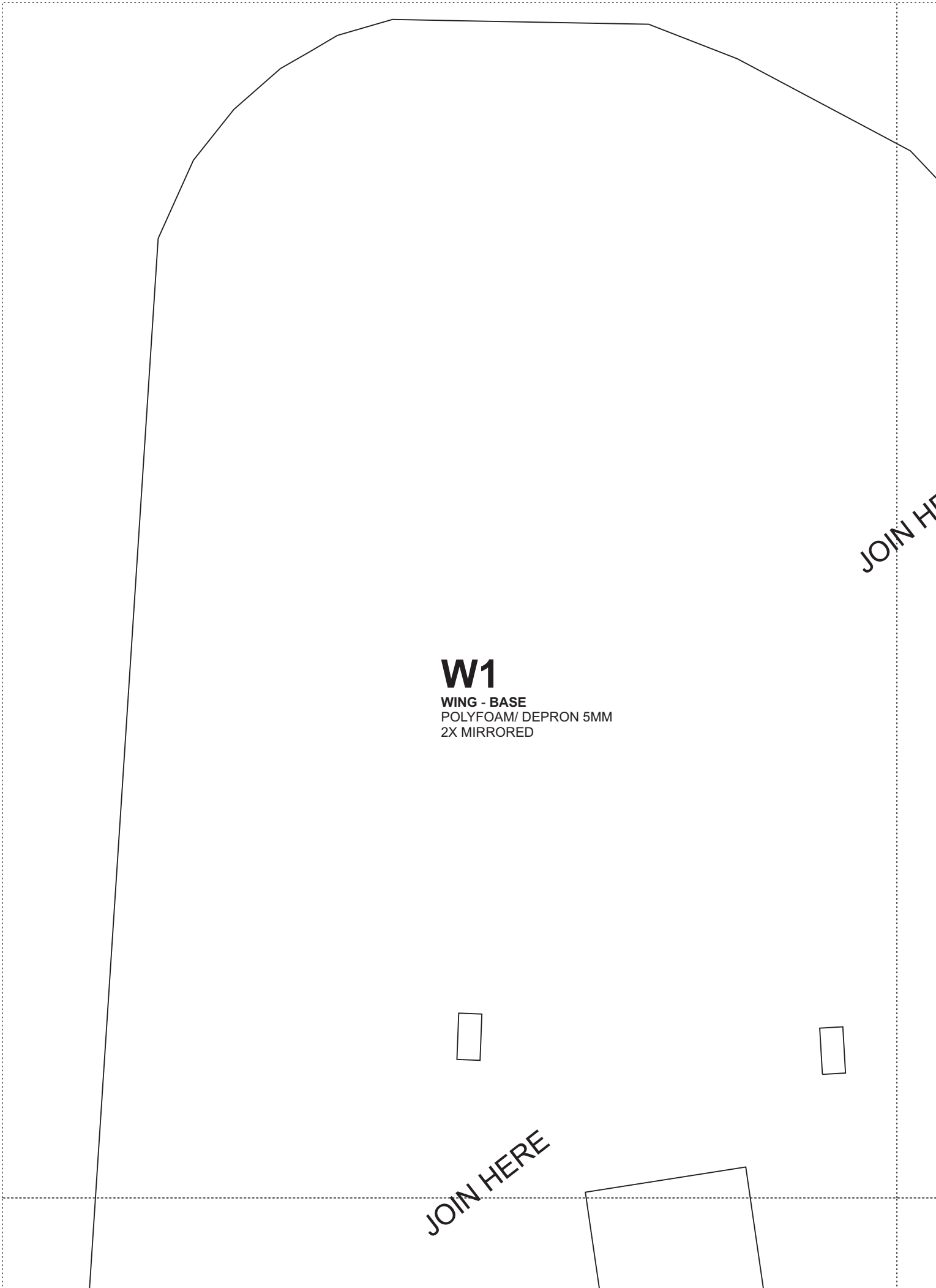

# W1

WING - BASE  
POLYFOAM/ DEPRON 5MM  
2X MIRRORED

JOIN HERE



JOIN HERE

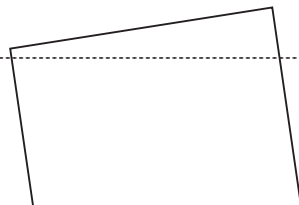

JOIN HERE

**W4**

LG SCREW MOUNTING  
PLYWOOD 3MM  
4X

**W3**

WING - SPAR  
POLYFOAM/  
DEPRON 5MM  
2X

**W4**

WING - SPAR  
POLYFOAM/  
DEPRON 5MM  
2X

**W2**

WING - FORMER  
POLYFOAM/  
DEPRON 5MM  
2X

W1

JOIN HERE

JOIN HERE

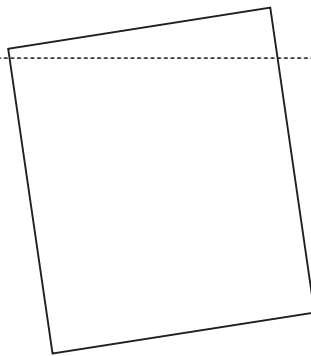

W1



JOIN HERE

JOIN HERE

JOIN HERE

W1



# W7

MID WING - BASE  
POLYFOAM/ DEPRON 5MM  
2X MIRRORED

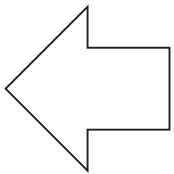

OUTER WING



JOIN HERE

JOIN HERE

W7

**W9**

MID WING - SPAR  
POLYFOAM/ DEPRON 5MM  
2X MIRRORED

**W10**

MID WING - SPAR  
POLYFOAM/  
DEPRON 5MM  
2X MIRRORED

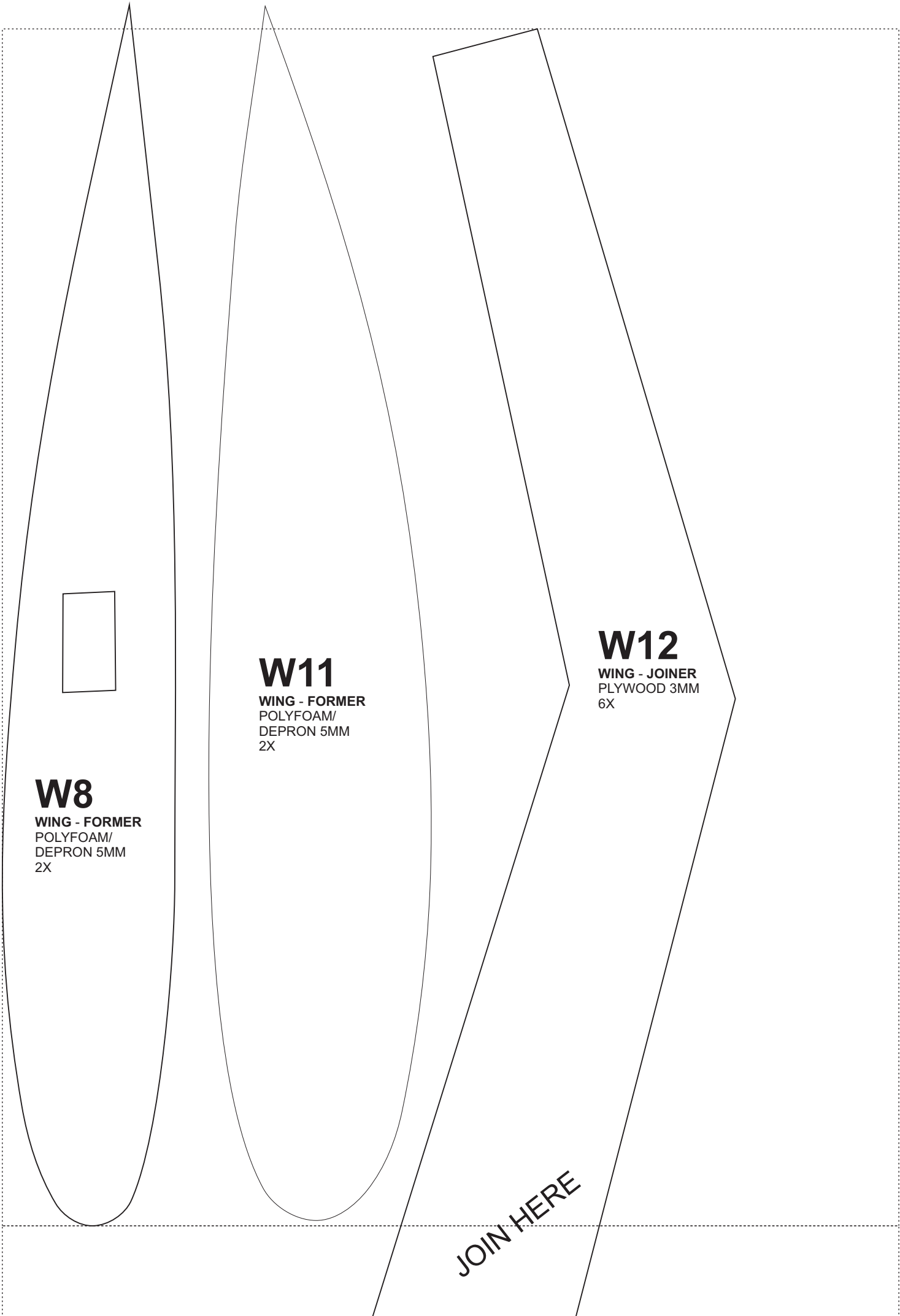

**W8**

WING - FORMER  
POLYFOAM/  
DEPRON 5MM  
2X

**W11**

WING - FORMER  
POLYFOAM/  
DEPRON 5MM  
2X

**W12**

WING - JOINER  
PLYWOOD 3MM  
6X

JOIN HERE



JOIN HERE

W12



**F15**

FIREWALL/ MOTOR MOUNT  
POLYFOAM/ DEPRON 5MM  
2X

# W13

MID WING - TOP  
POLYFOAM/ DEPRON 5MM  
2X MIRRORED

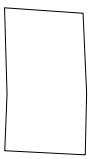

OUTER WING

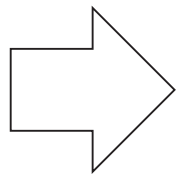

**W13**

**W14**

WING JOINER  
PLYWOOD 3MM

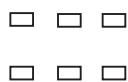
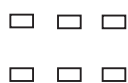

**G1**

LG BASE  
PLYWOOD 3MM

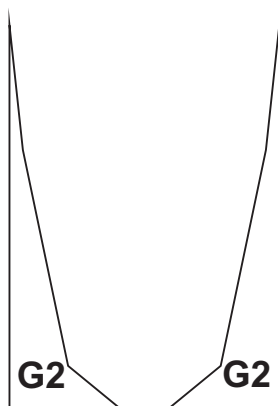

**G2**

**G2**

**G3**

LG BASE  
PLYWOOD 3MM

**W15**

WING DETAIL  
PLYWOOD 3MM  
2X MIRRORED

**S2A**

HOR-STAB  
POLYFOAM/  
DEPRON 5MM  
2X MIRRORED

**W6**

OUTER WING - TOP  
POLYFOAM/ DEPRON 5MM  
2X MIRRORED

JOIN HERE

JOIN HERE

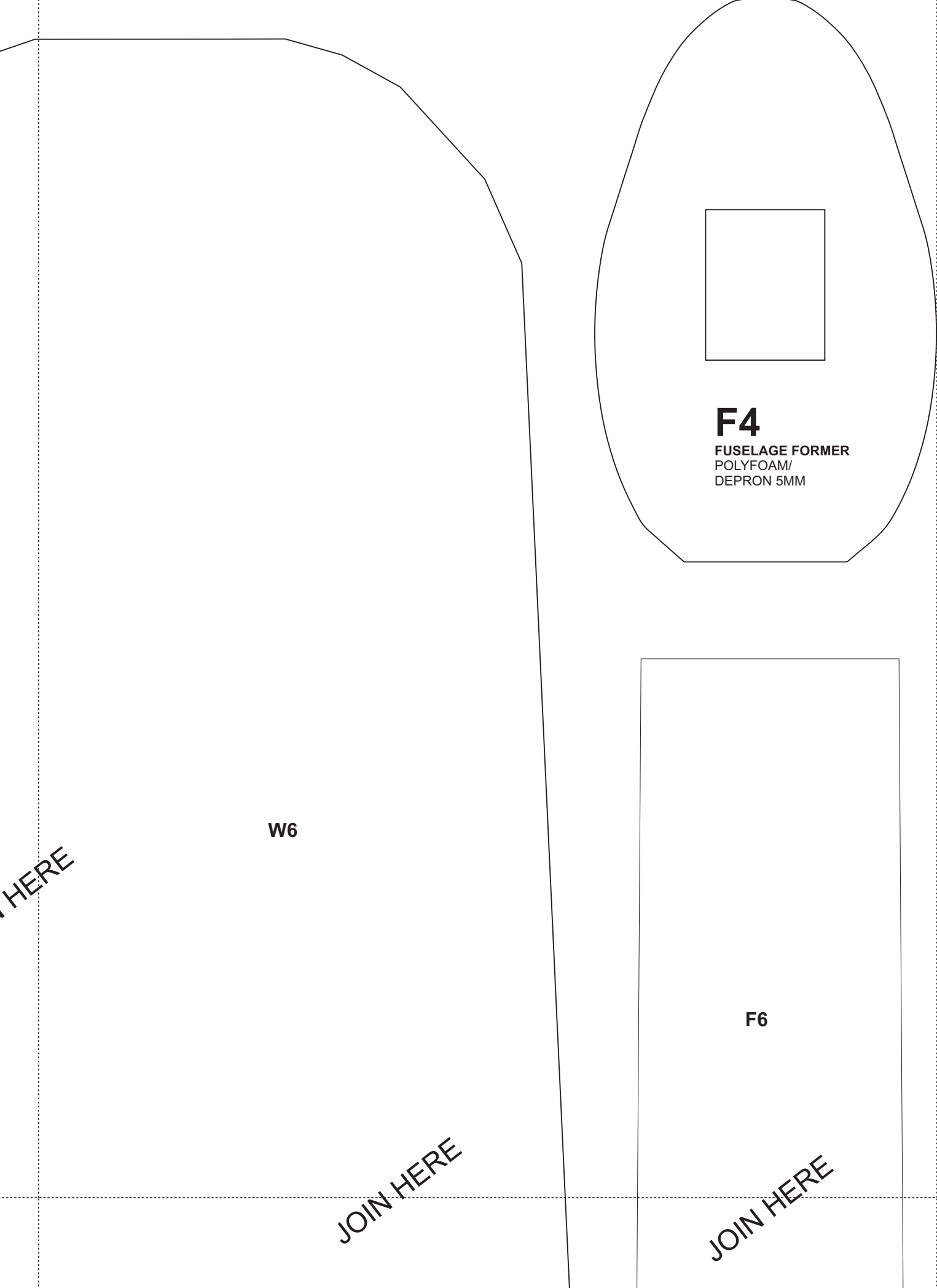

W6



**F4**  
FUSELAGE FORMER  
POLYFOAM/  
DEPRON 5MM

F6

JOIN HERE

JOIN HERE

HERE

JOIN HERE

JOIN HERE

W6

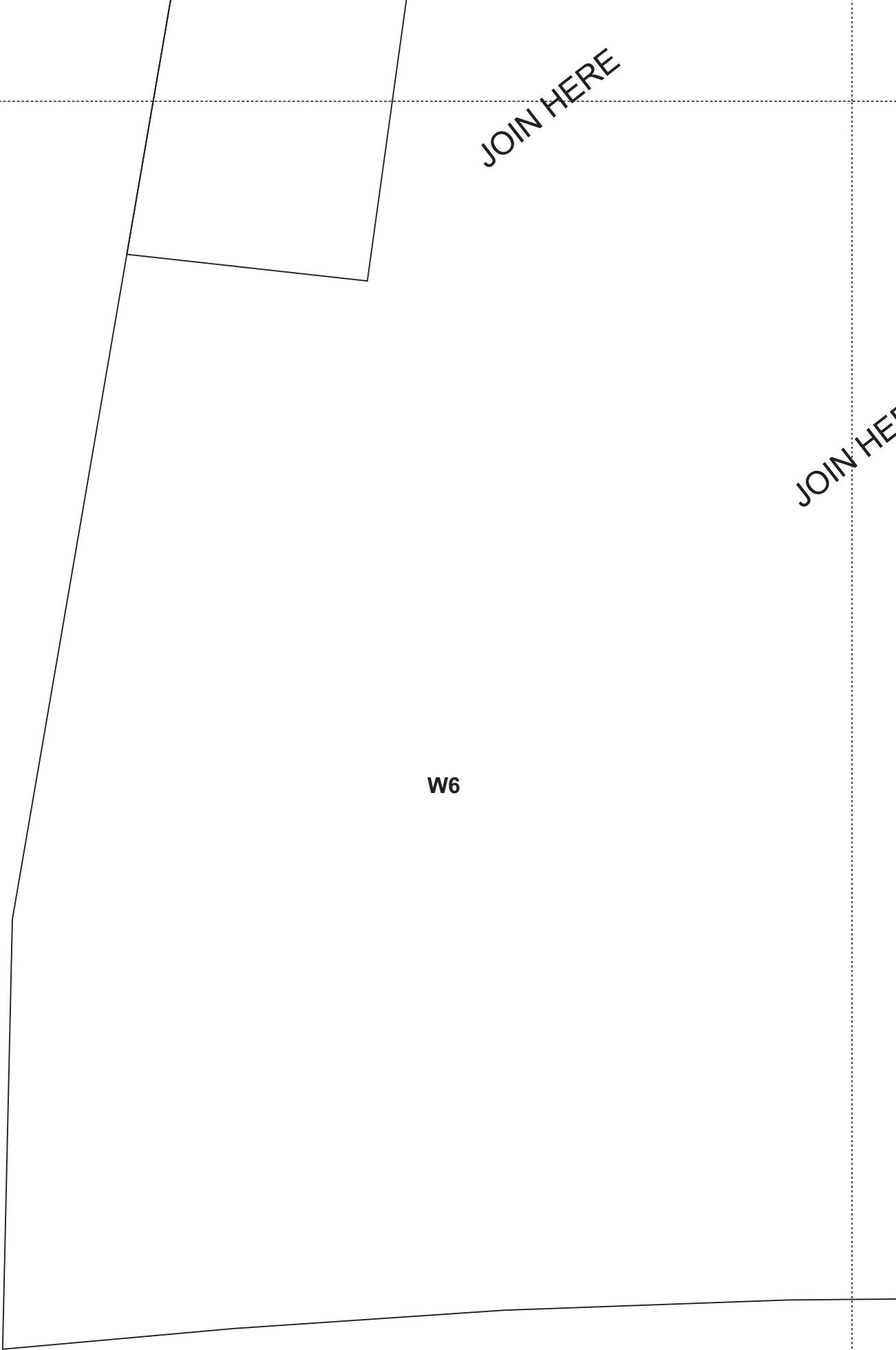

JOIN HERE

JOIN HERE

JOIN HERE

**F6**  
FUSELAGE  
POLYFOAM/  
DEPRON 5MM

**W6**

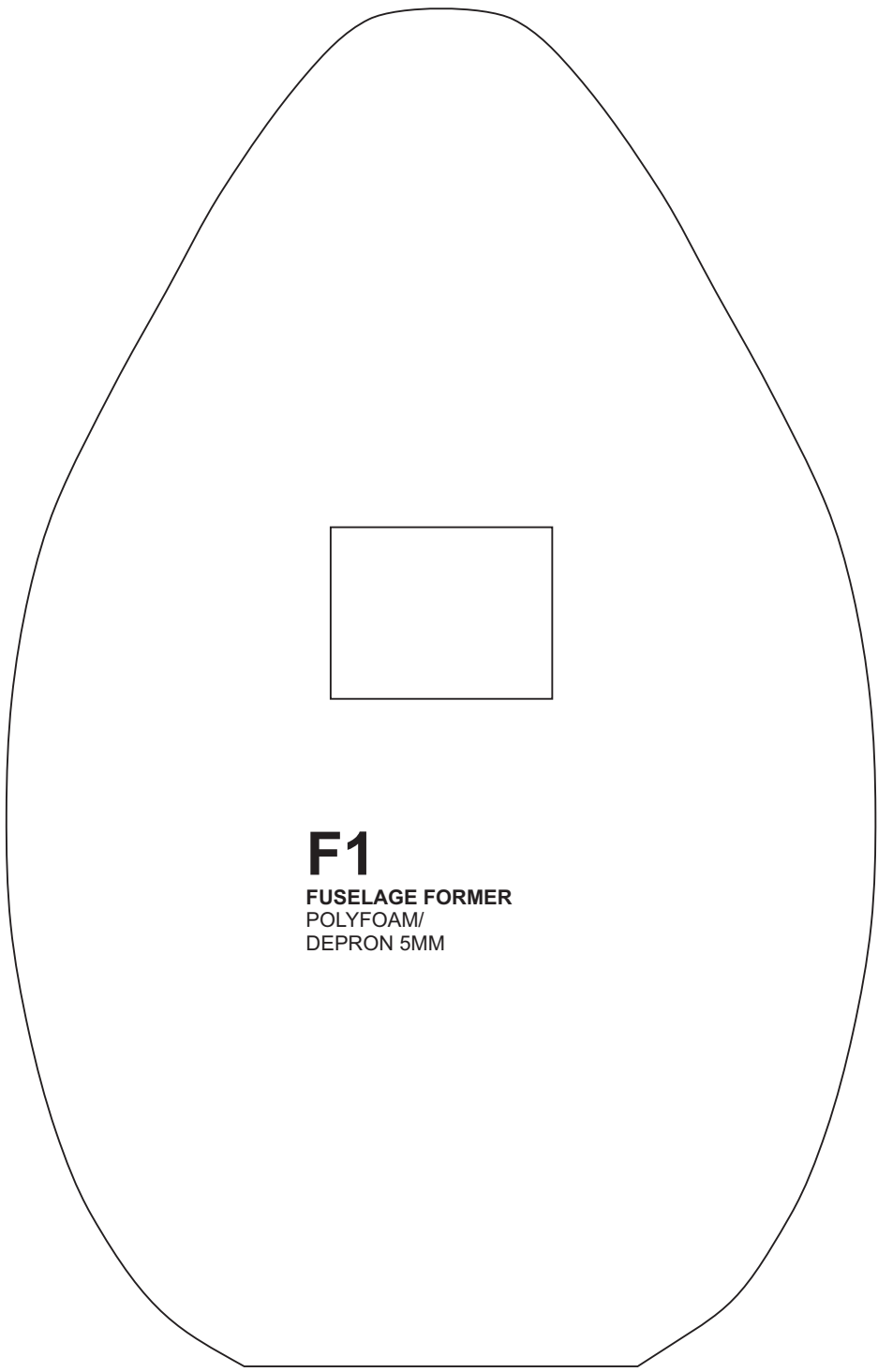

**F1**

**FUSELAGE FORMER**  
POLYFOAM/  
DEPRON 5MM

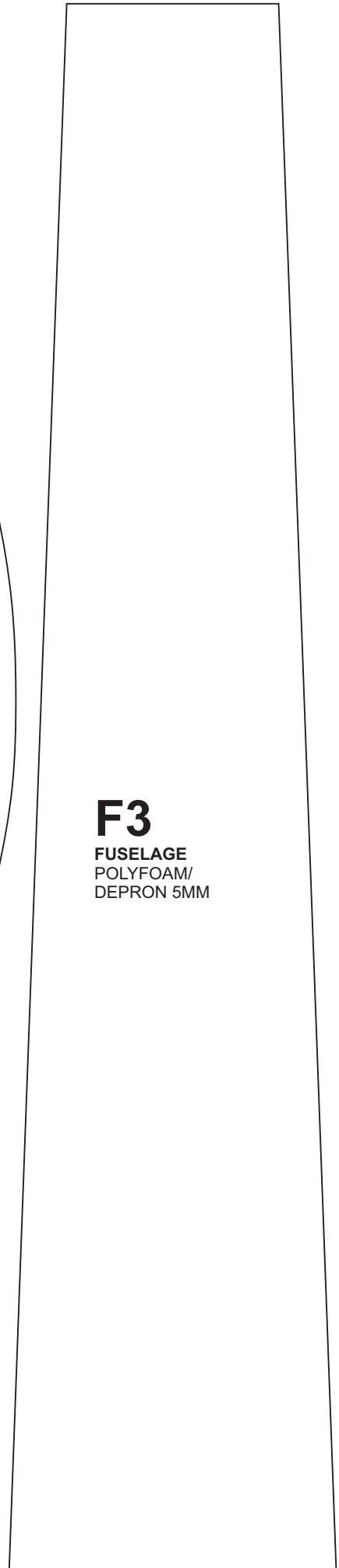

**F3**

**FUSELAGE**  
POLYFOAM/  
DEPRON 5MM



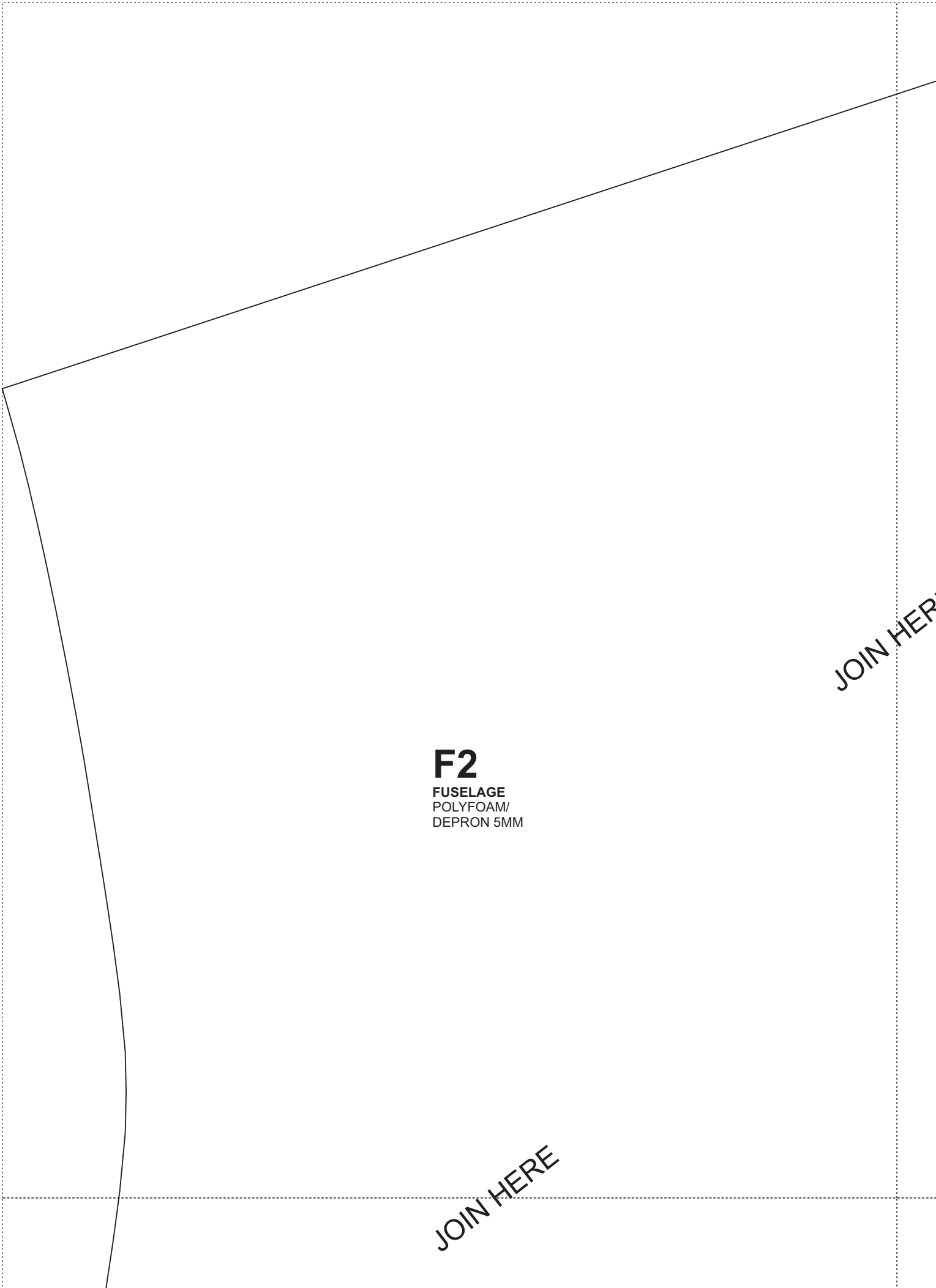

**F2**

FUSELAGE  
POLYFOAM/  
DEPRON 5MM

JOIN HERE

JOIN HERE

JOIN HERE

F2

JOIN HERE

**F19**  
COWL  
POLYFOAM/  
DEPRON 5MM

JOIN HERE

JOIN HERE

F2

JOIN HERE

JOIN HERE

JOIN HERE

F19

F2

JOIN HERE

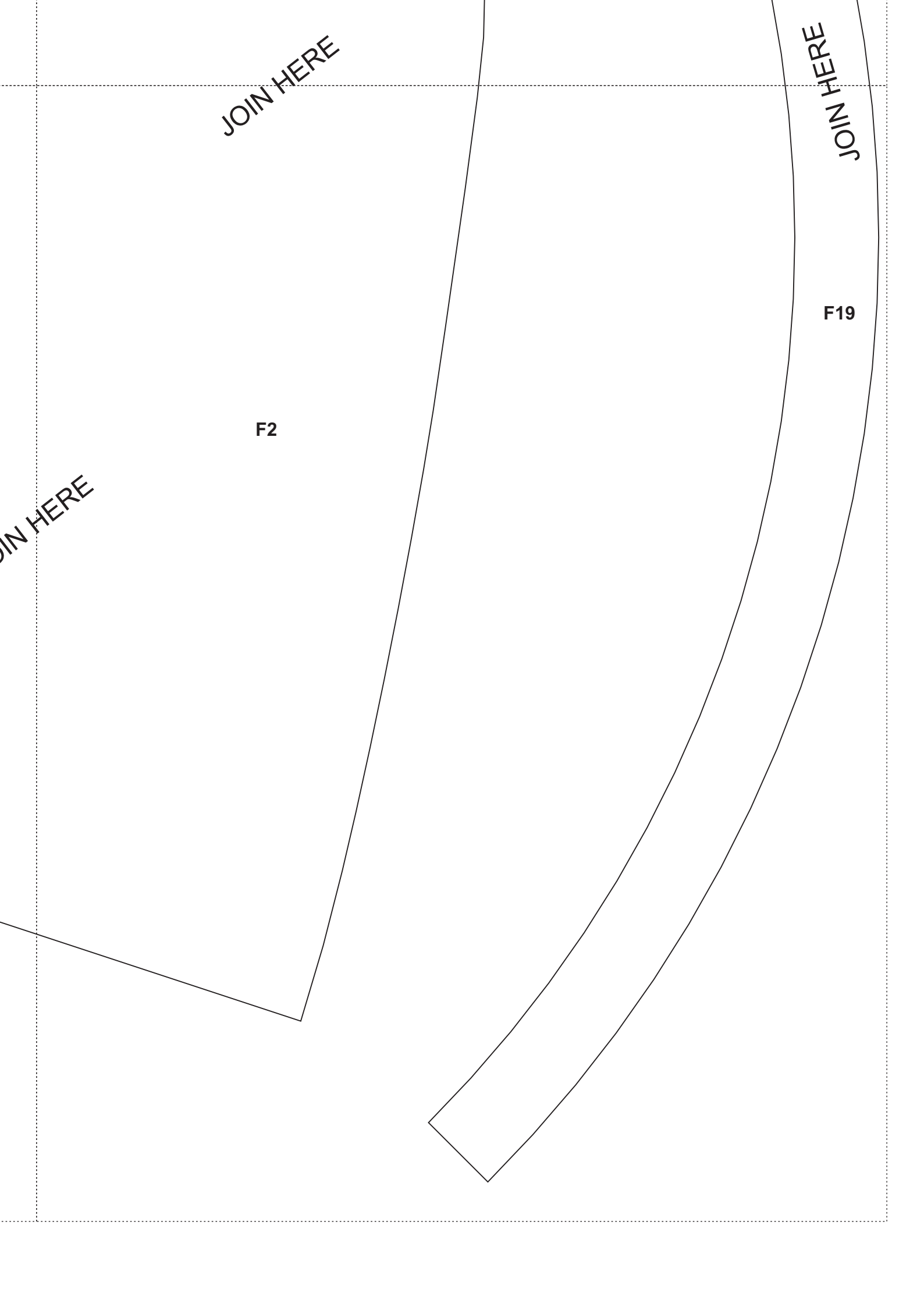



**F5**

FUSELAGE  
POLYFOAM/  
DEPRON 5MM

JOIN HERE

JOIN HERE

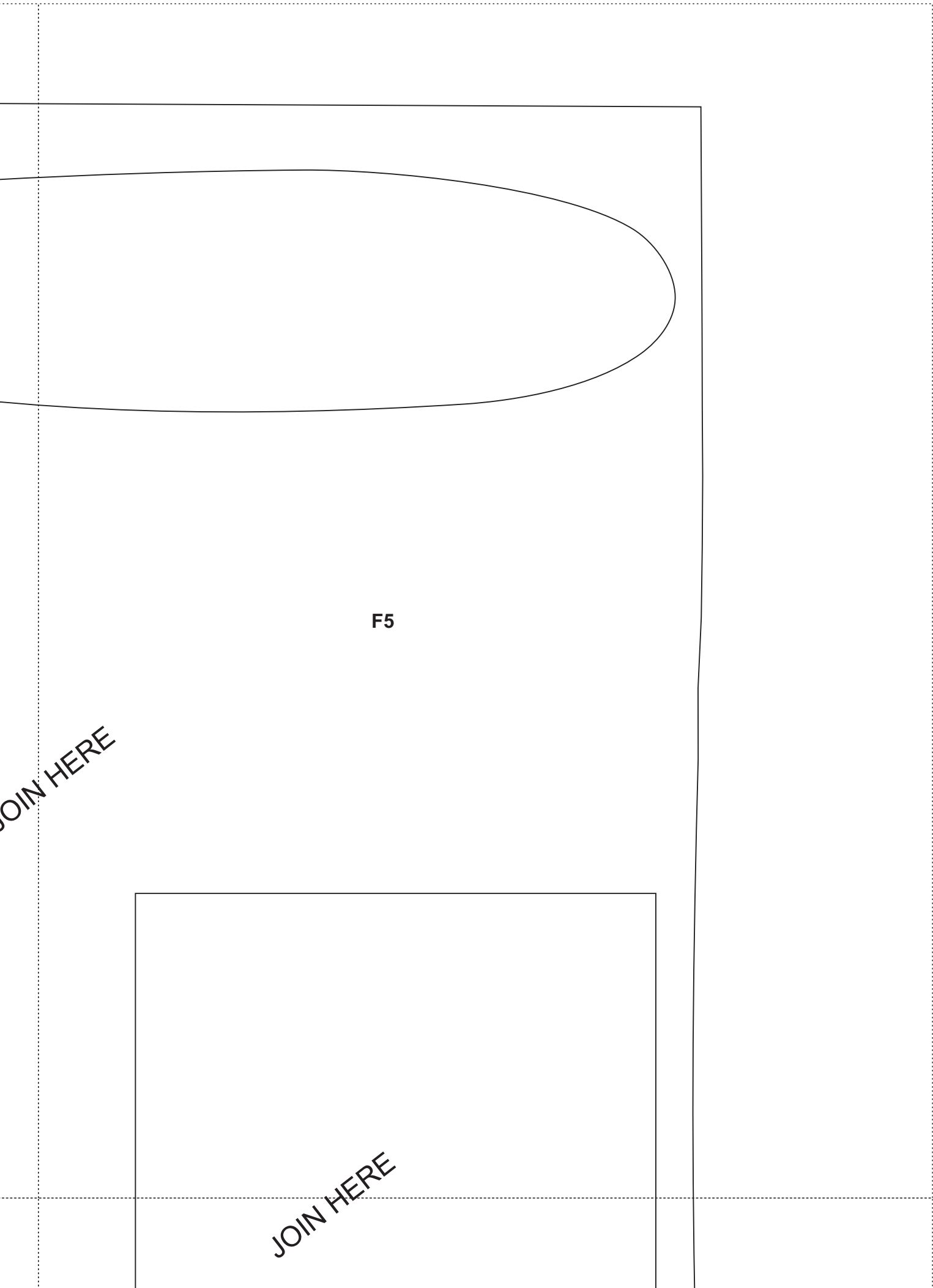

**F5**

**JOIN HERE**

**JOIN HERE**

JOIN HERE

F5

JOIN HERE

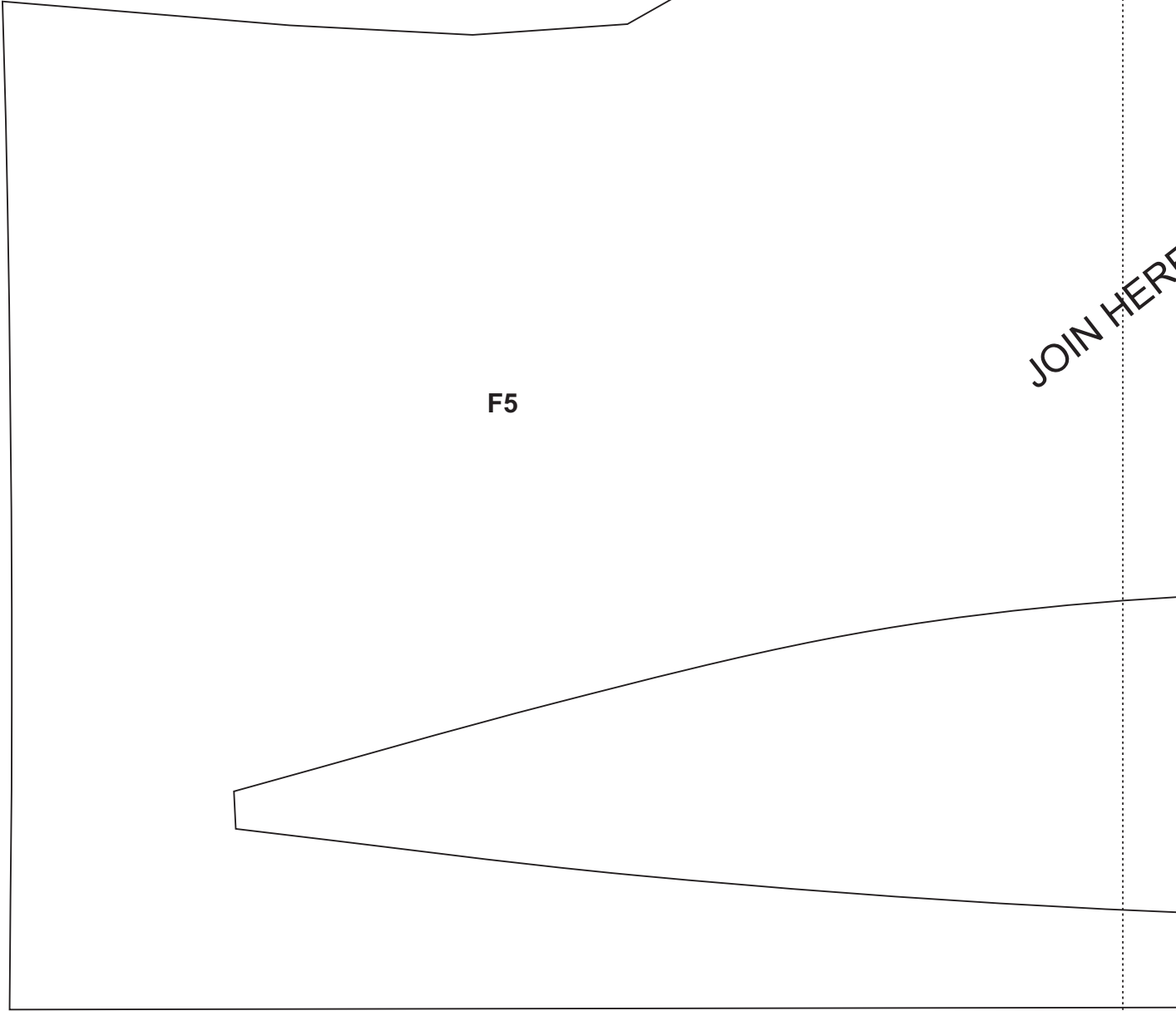

JOIN HERE

F5

IN HERE

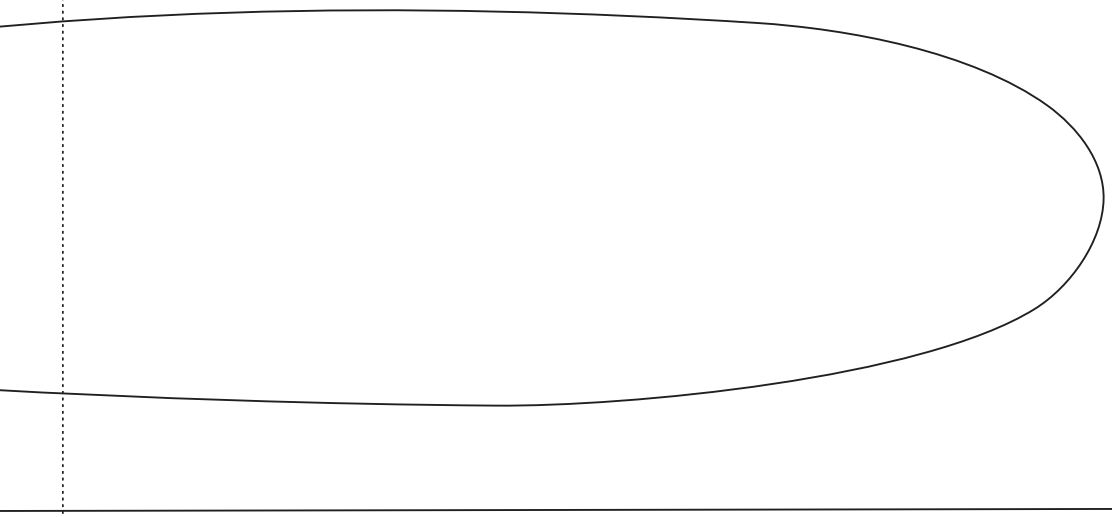



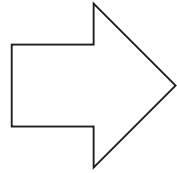

RIGHT

**F7**

FUSELAGE  
POLYFOAM/  
DEPRON 5MM

JOIN HERE

**F8**

FUSELAGE  
POLYFOAM/  
DEPRON 5MM  
2X

JOIN HERE

JOIN HERE

**F7**

JOIN HERE

**F8**



**F12**

REAR LG  
PLYWOOD  
3MM

**F10**

TAIL  
POLYFOAM/  
DEPRON 5MM

JOIN HERE

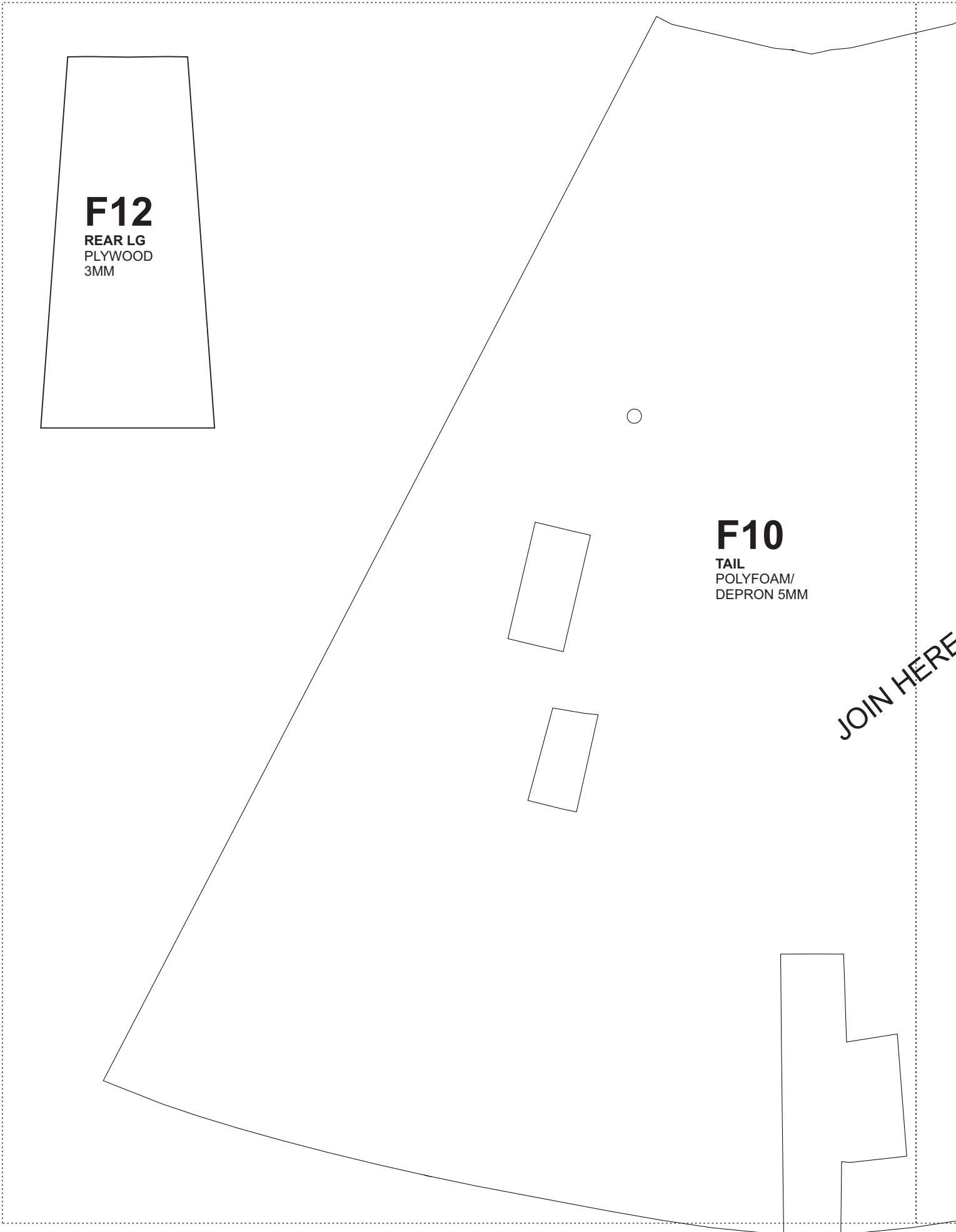

IN HERE

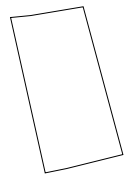
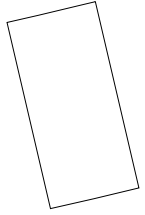

**F10**

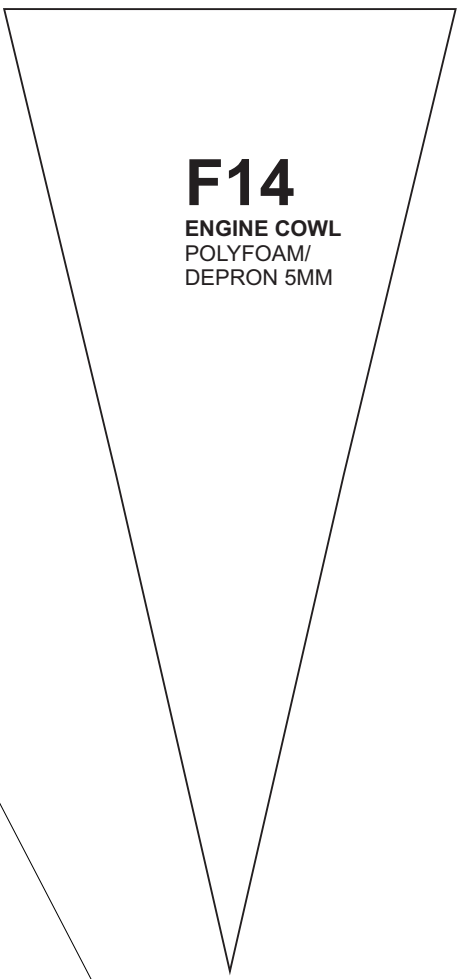

**F14**  
ENGINE COWL  
POLYFOAM/  
DEPRON 5MM

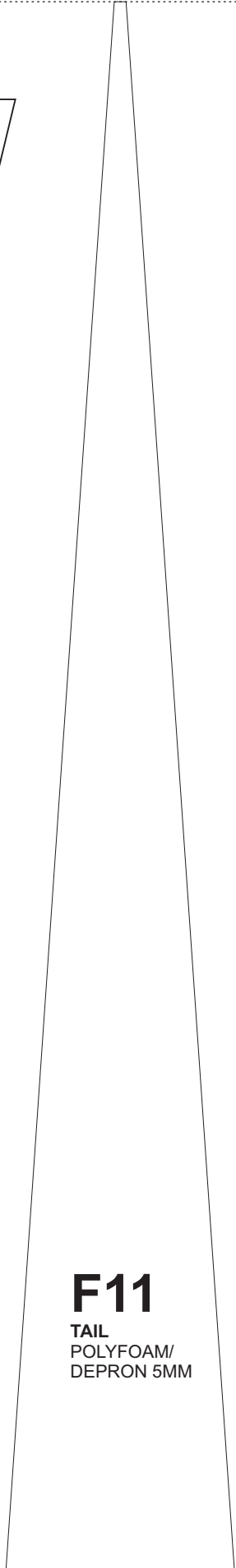

**F11**  
TAIL  
POLYFOAM/  
DEPRON 5MM

JOIN HERE

# F13

ENGINE COWL  
POLYFOAM/  
DEPRON 5MM

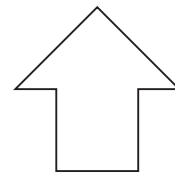

LEFT

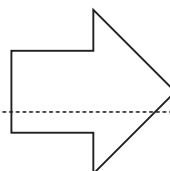

FRONT

JOIN HERE

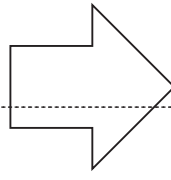

FRONT

**F13**

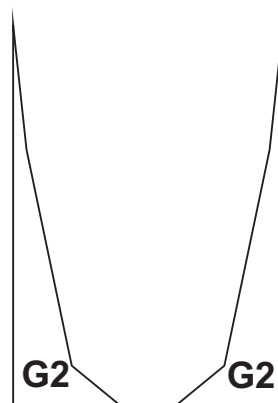
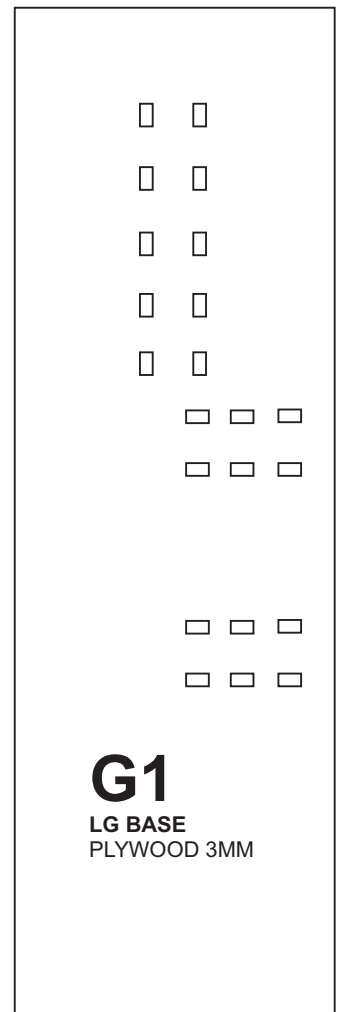
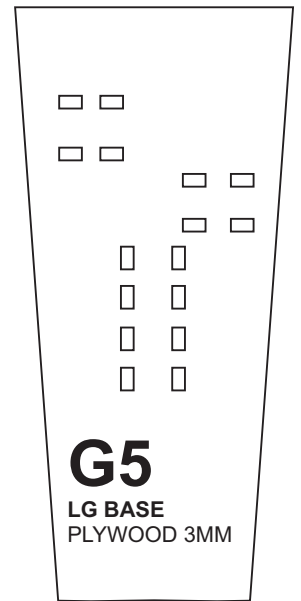

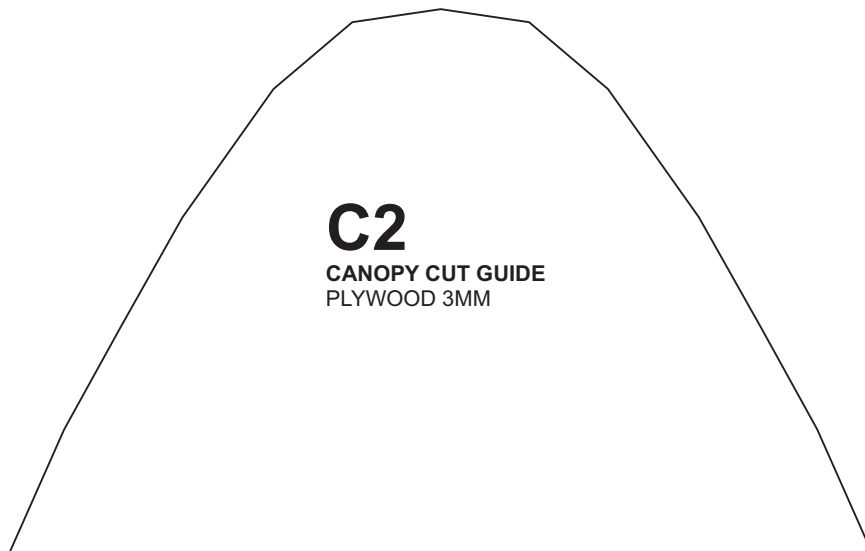
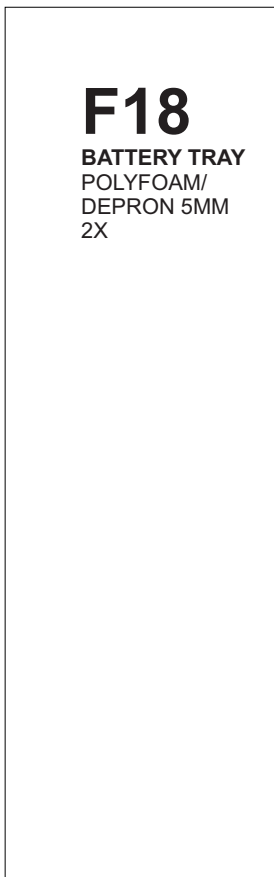
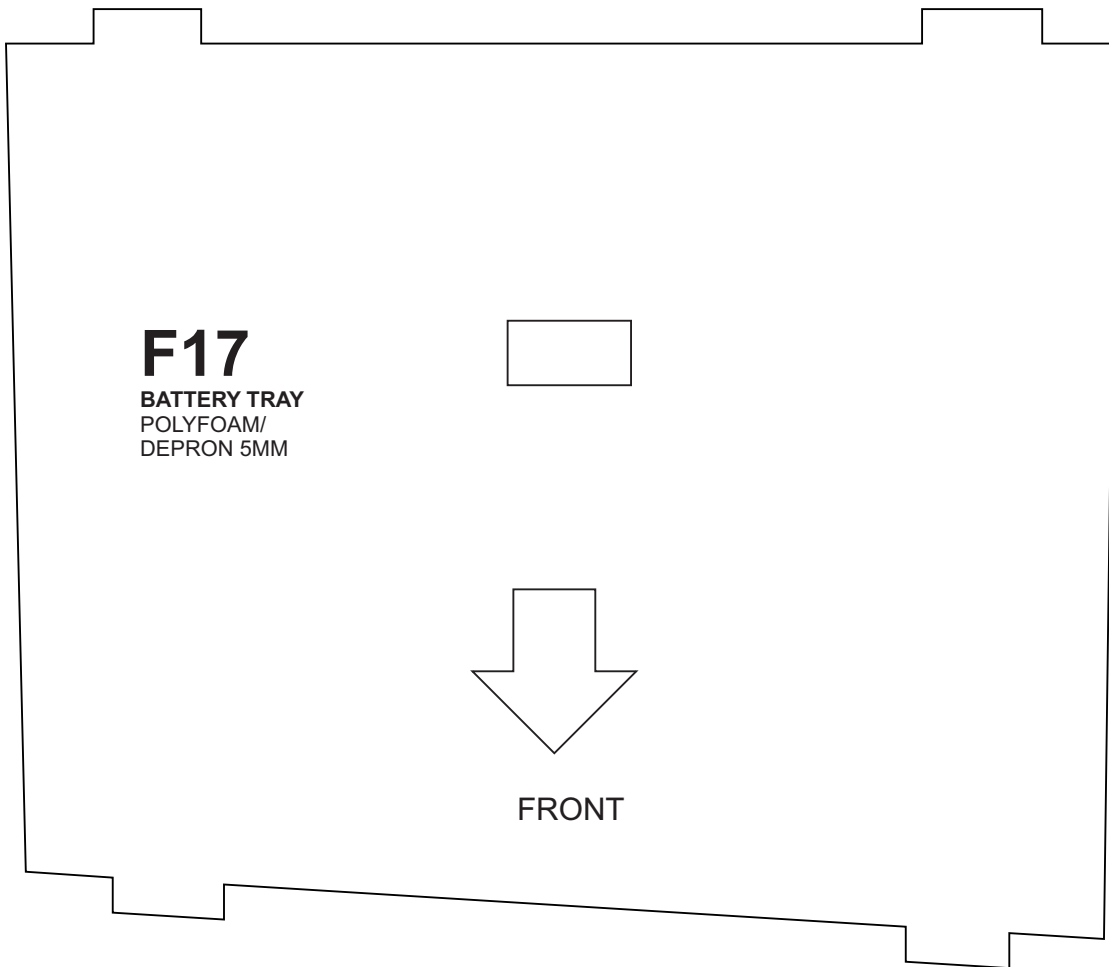



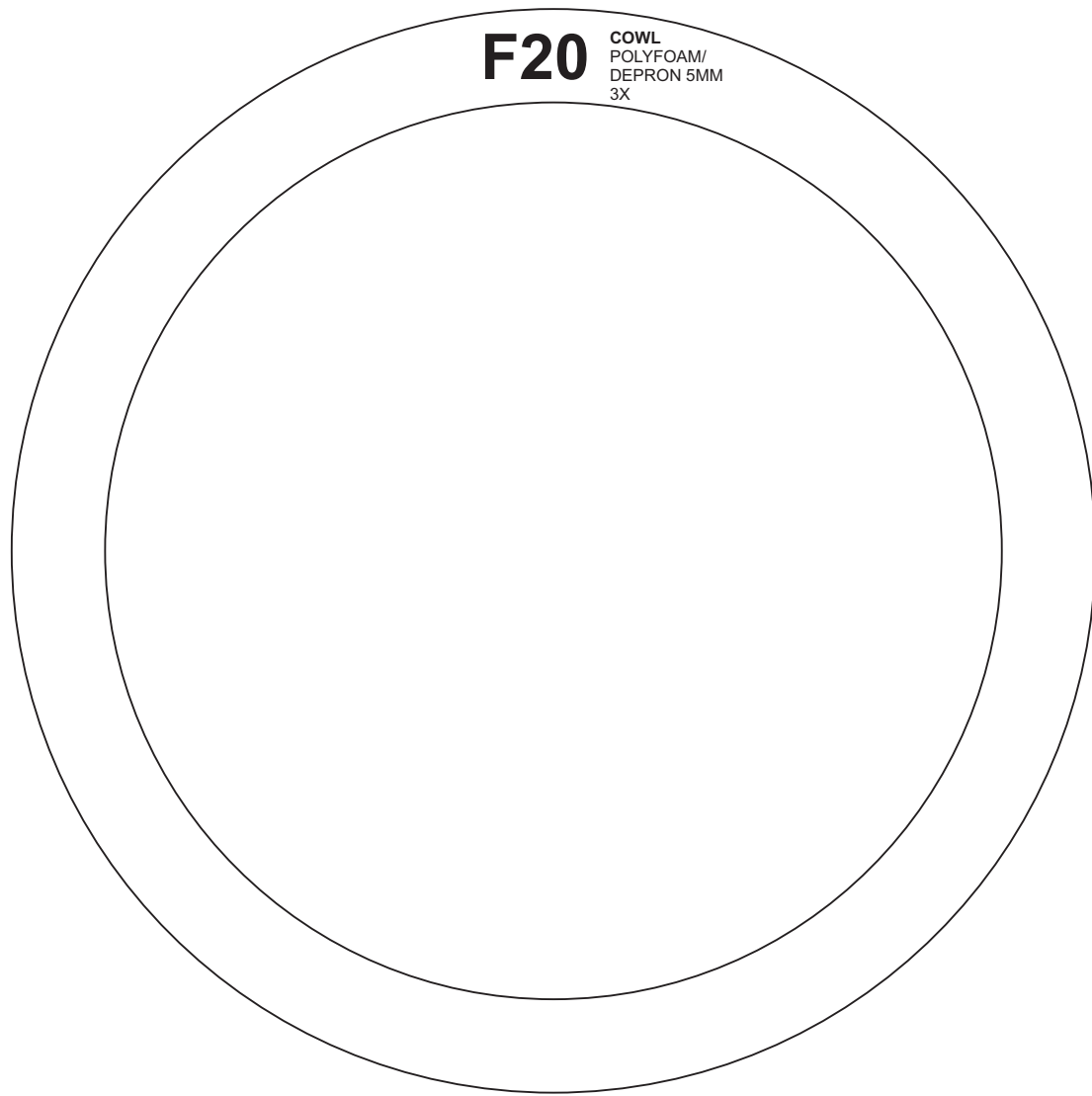

**F20** COWL  
POLYFOAM/  
DEPRON 5MM  
3X

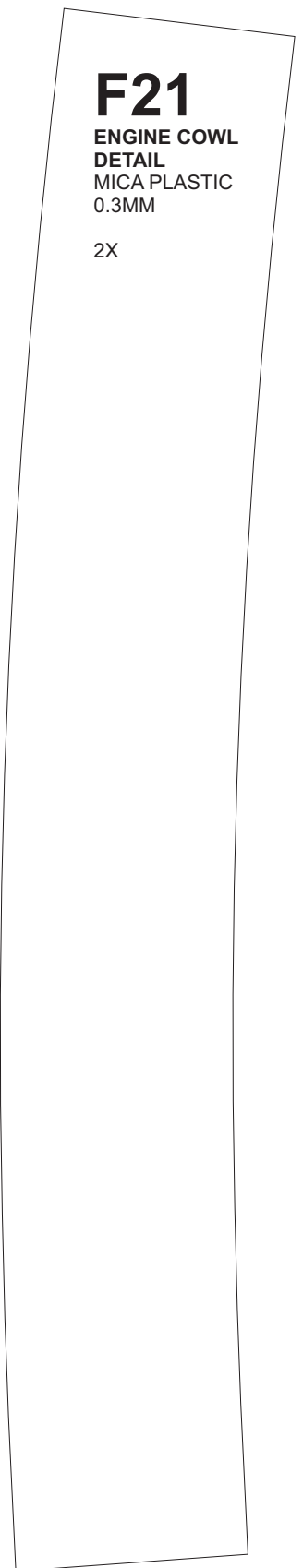

**F21** ENGINE COWL  
DETAIL  
MICA PLASTIC  
0.3MM

2X

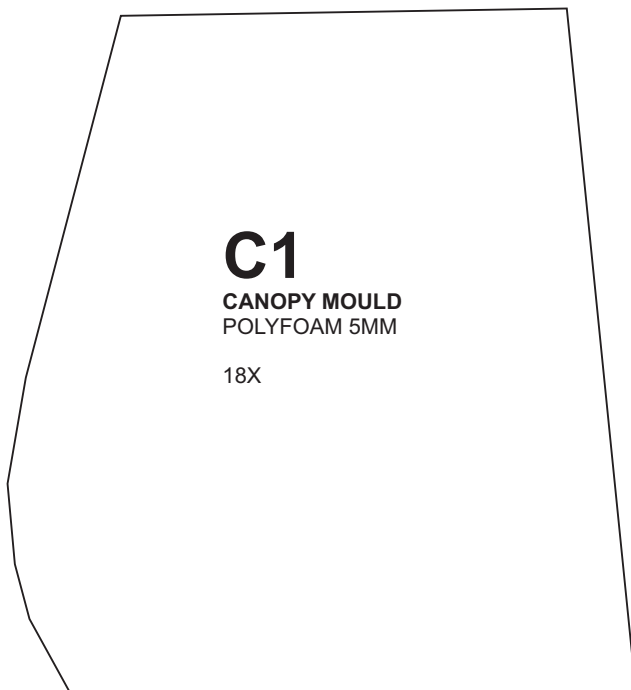

**C1** CANOPY MOULD  
POLYFOAM 5MM

18X



**S4**

**VERTICAL STAB**  
POLYFOAM/  
DEPRON 5MM  
2X

**S5**

**RUDDER**  
POLYFOAM/  
DEPRON 5MM  
2X



**S3**

**ELEVATOR**  
POLYFOAM/  
DEPRON 5MM  
4X MIRRORED

**S2**

**HOR-STAB**  
POLYFOAM/  
DEPRON 5MM  
2X MIRRORED

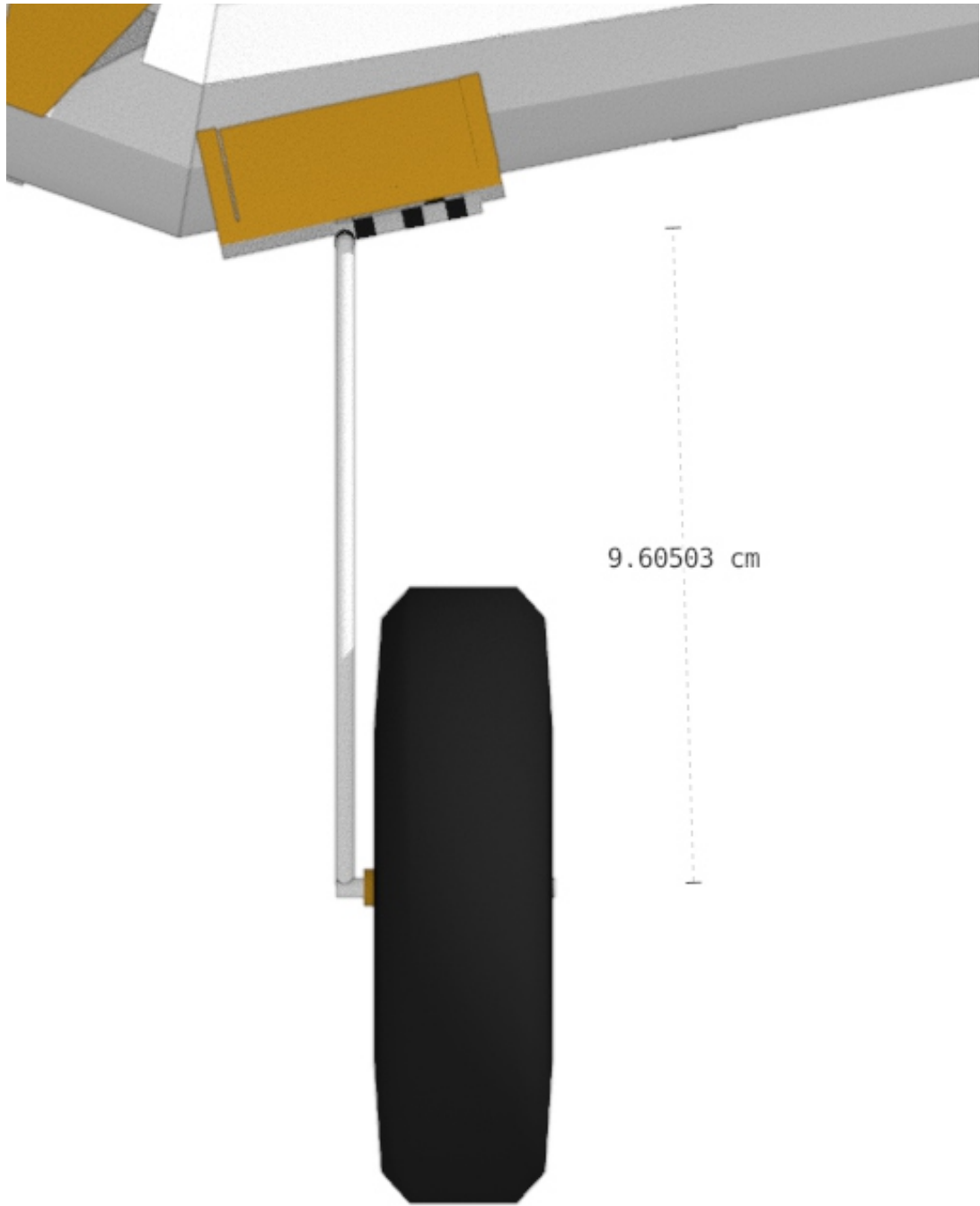

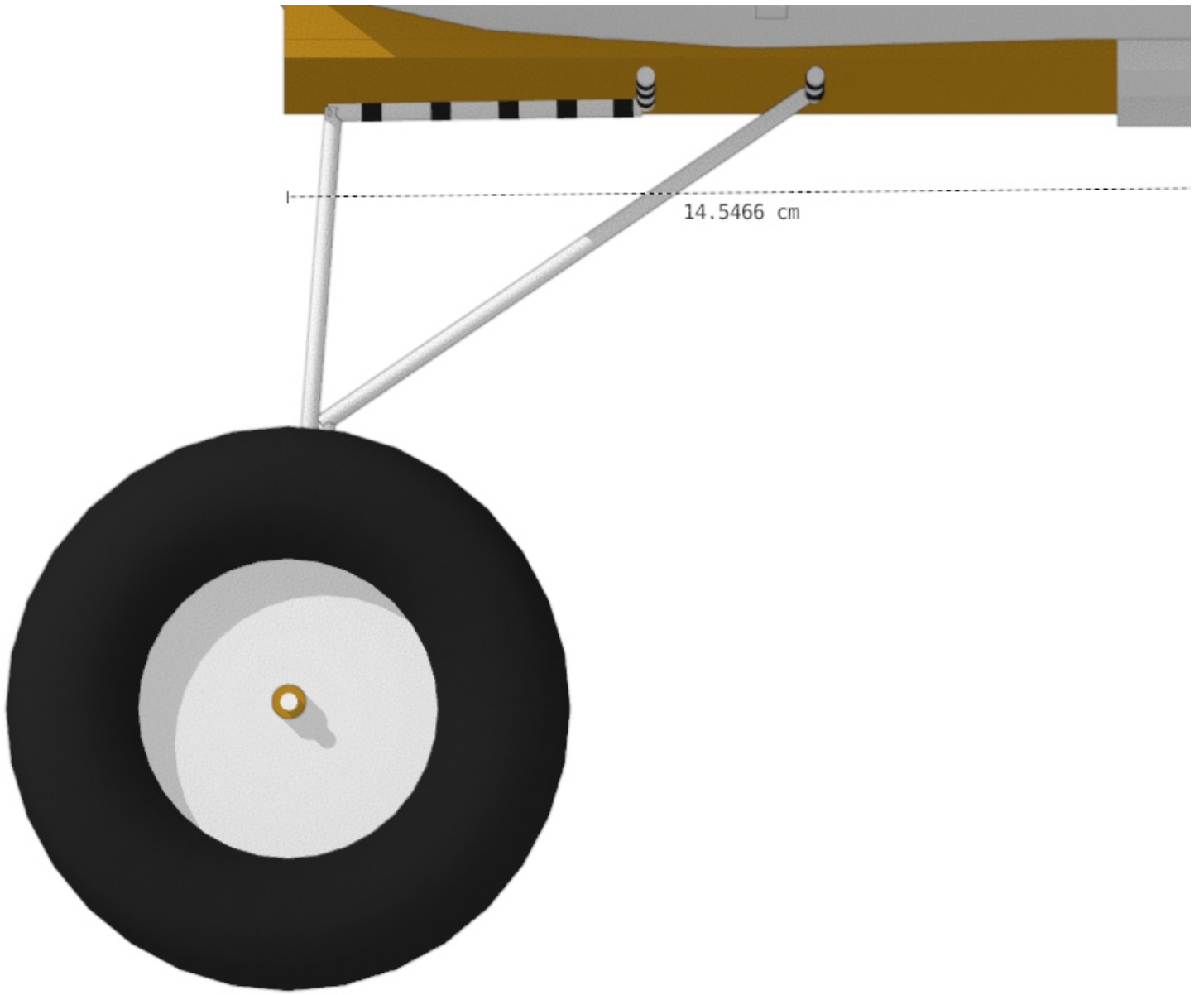

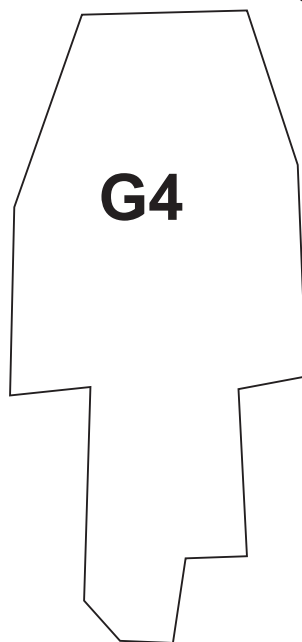
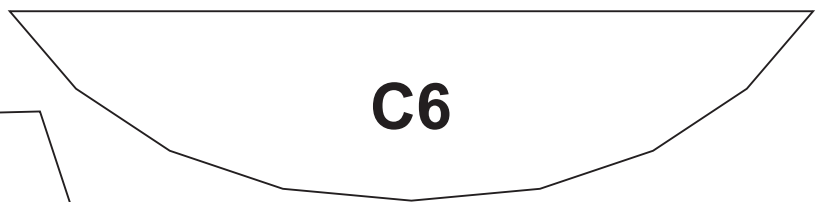
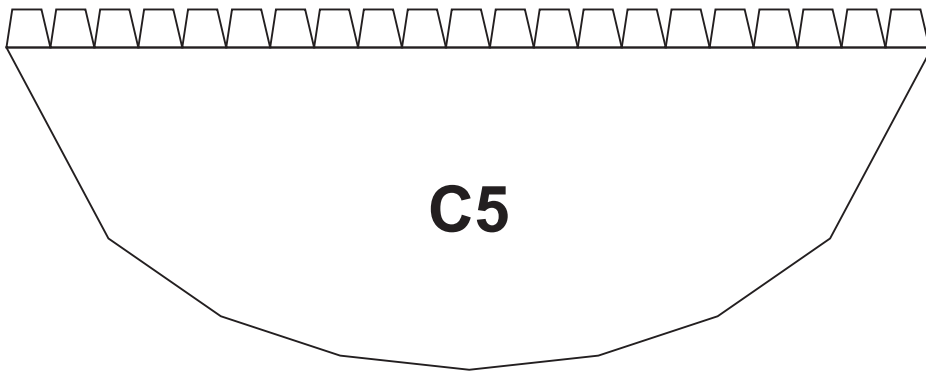
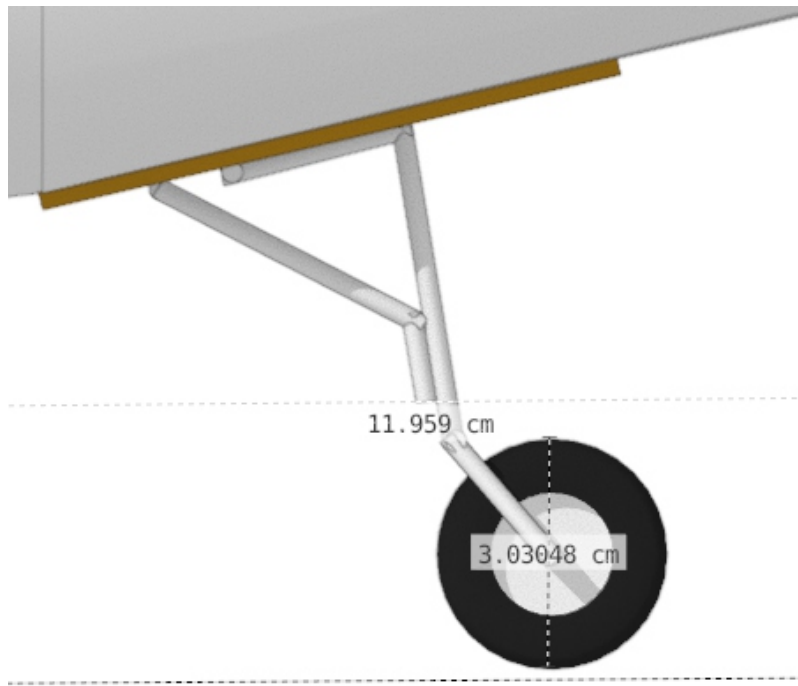



**C7**

**WINDSHIELD  
MICA PLASTIC  
0.3MM**

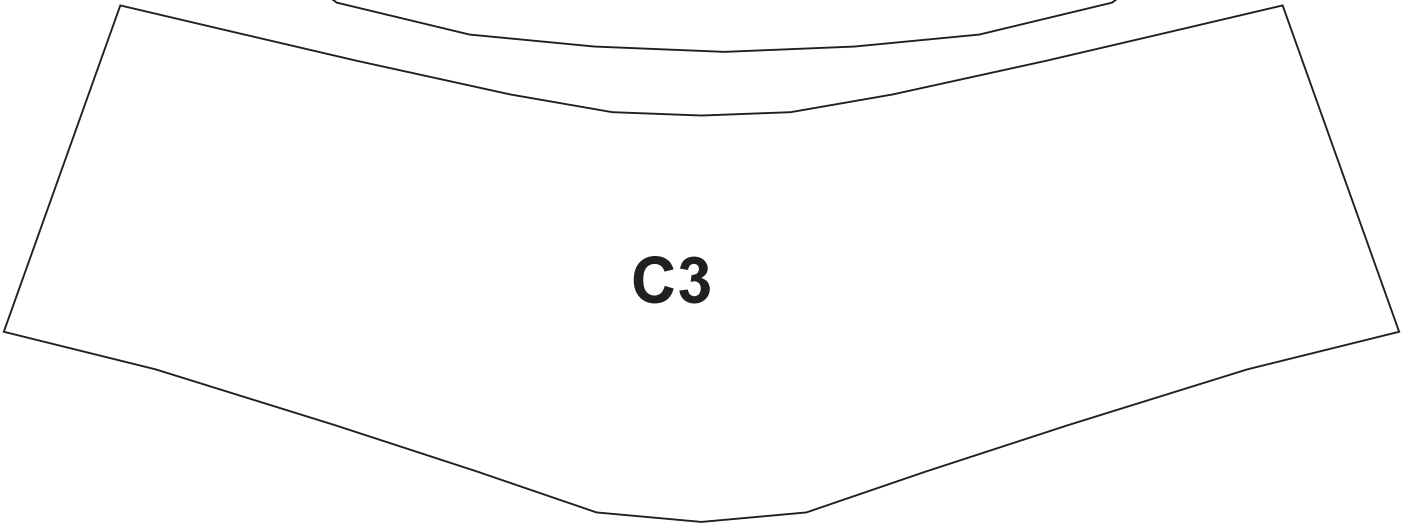

**C3**

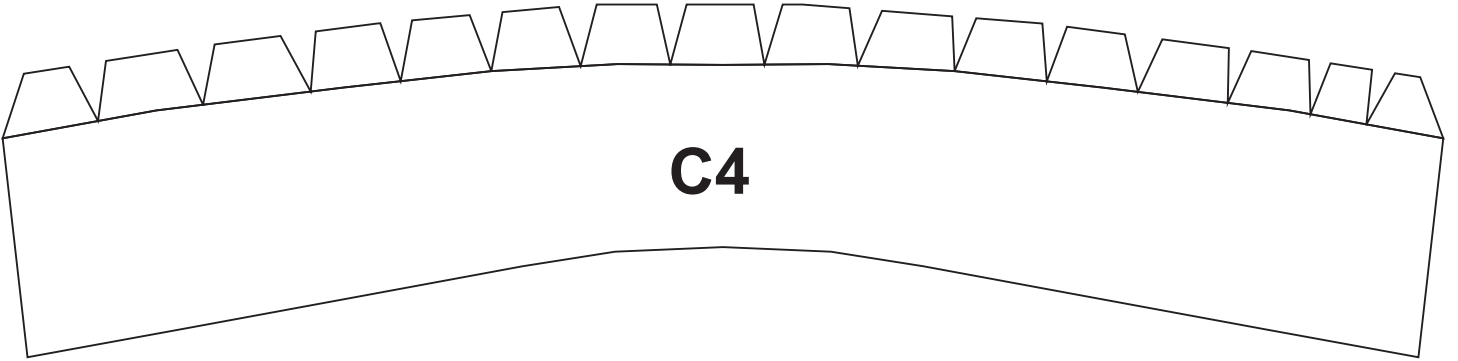

**C4**