



Model : 43/2023



# F-22 Raptor

## 1000mm

### Specs :

1. Wingspan 1000mm / 39.37 inches
2. Flying weight : 1028 grams/ 36.3 oz
3. Wing loading : 20.4 gram/dm<sup>2</sup> - 6.7 oz/sq.ft.
4. Wing cube loading : 2.9
5. Wing Area : 50.35 dm<sup>2</sup> / 780 sq.in.
6. CG : 13.7 cm / 5.39 inch from Wing Break

### Electronics for test

- DXW 3536 1200kv
- Prop 10x6 (2 blades)
- 50A ESC
- Battery Lipo 4S 2200mah
- 4 x 9 gram servos (micro servo)

### Transmitter

- Jumper T16 + BetaFPV Express LRS TX module
- 5 ch BetaFPV Express LRS RX

### Materials :

1. 5mm Foamboard/ Depron/ Polyfoam
2. 10mm Carbon Tube/ Bamboo/ Wood Dowel 1 meter
3. 0.3mm Mica Plastic
4. hot glue, UHU glue, CA glue, PVA glue
5. Wax paper

### Build Instructions :

1. [paper-replika.com](http://paper-replika.com)
2. youtube channel : Julius Perdana

# F1

FUSELAGE  
POLYFOAM/  
DEPRON 5MM

JOIN HERE

JOIN HERE

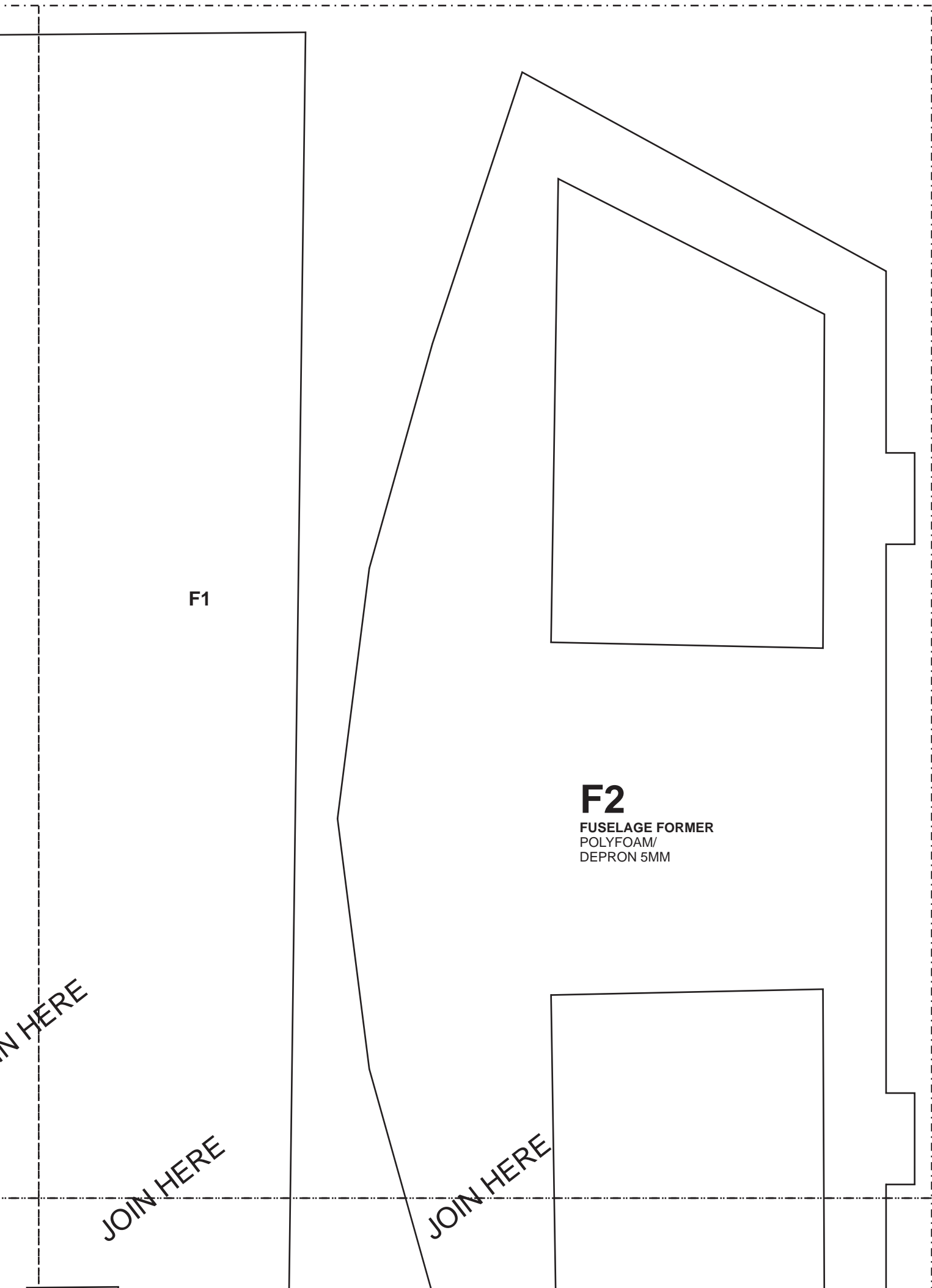

**F1**

**F2**

FUSELAGE FORMER  
POLYFOAM/  
DEPRON 5MM

JOIN HERE

JOIN HERE

JOIN HERE

JOIN HERE



F1

JOIN HERE



JOIN HERE

JOIN HERE

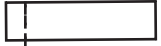

F2

JOIN HERE

F1

**F3**

FUSELAGE  
POLYFOAM/  
DEPRON 5MM  
2X MIRRORED

JOIN HERE

JOIN HERE

**F3**

JOIN HERE

JOIN HERE

F3

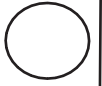

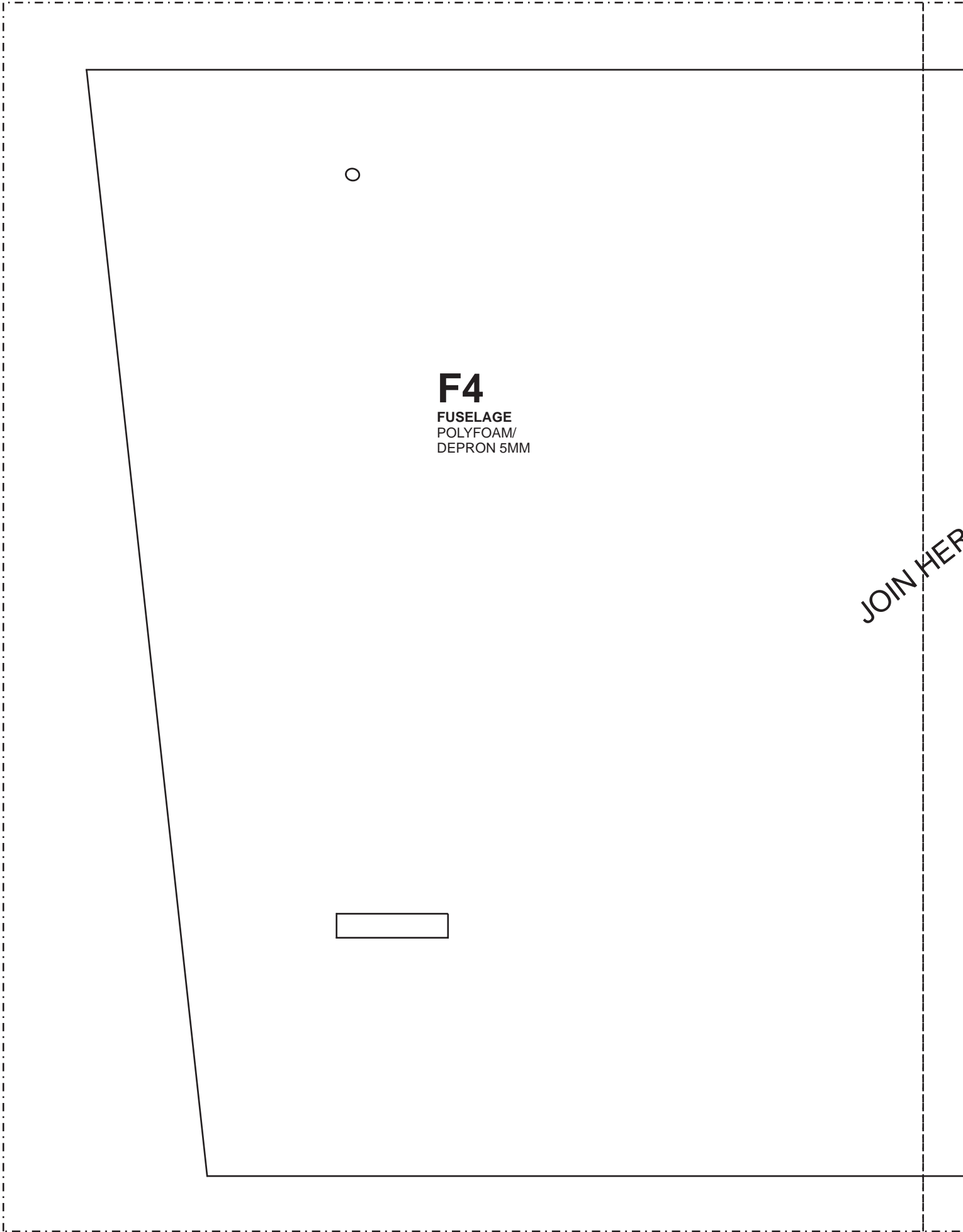

**F4**

FUSELAGE  
POLYFOAM/  
DEPRON 5MM

JOIN HERE



JOIN HERE



**F4**



JOIN HERE

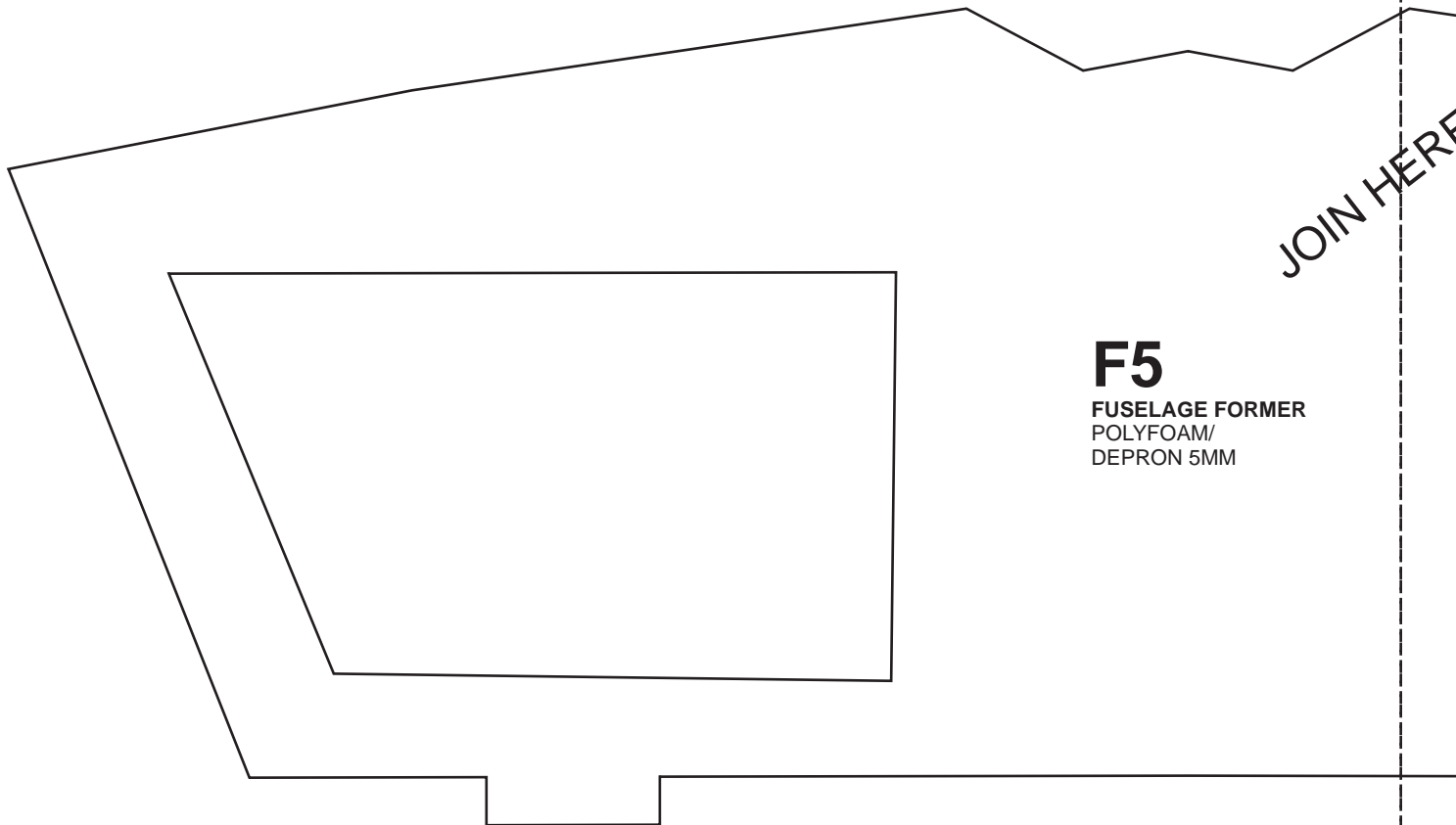

**F5**  
FUSELAGE FORMER  
POLYFOAM/  
DEPRON 5MM



UP

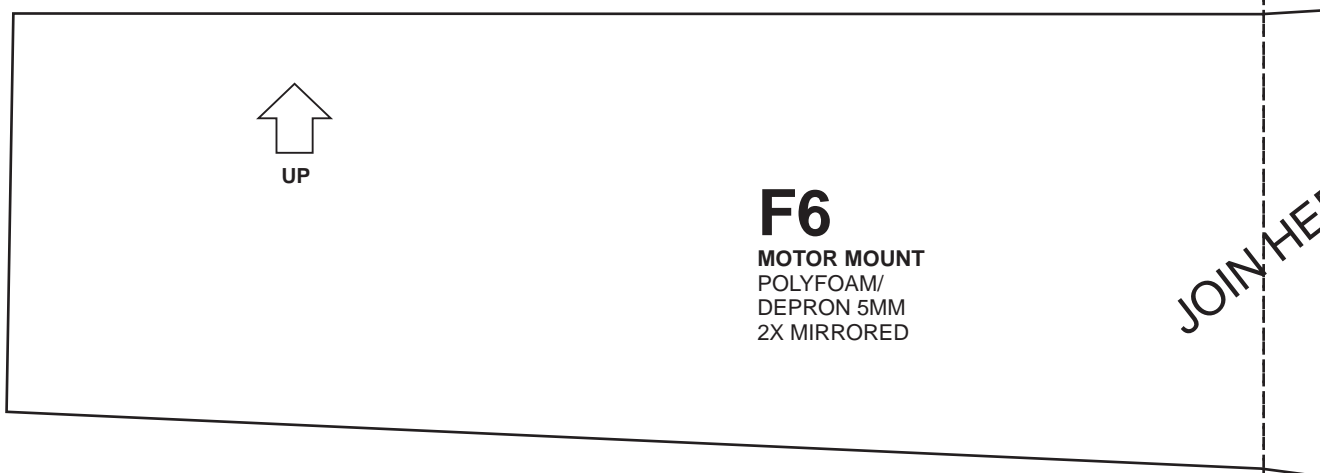

**F6**  
MOTOR MOUNT  
POLYFOAM/  
DEPRON 5MM  
2X MIRRORED

JOIN HERE

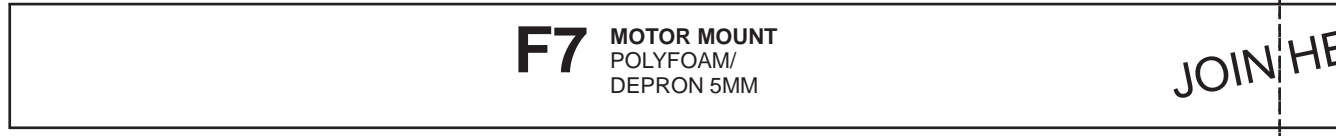

**F7** MOTOR MOUNT  
POLYFOAM/  
DEPRON 5MM

JOIN HERE

JOIN HERE

F5

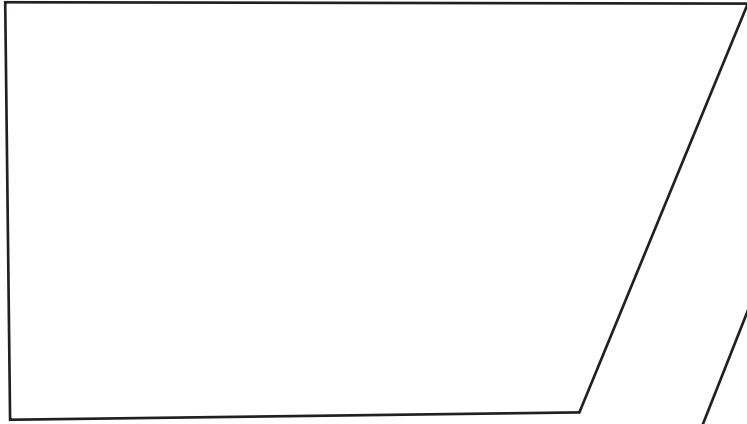

JOIN HERE

F6

JOIN HERE

F7

**F8**

MOTOR MOUNT  
POLYFOAM/  
DEPRON 5MM

# W1

WING  
POLYFOAM/  
DEPRON 5MM  
2X MIRRORED

JOIN HERE

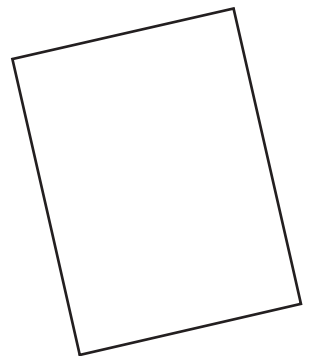

**F14**

FUSELAGE FORMER  
POLYFOAM/  
DEPRON 5MM

JOIN HERE

**W1**

**F9**

FUSELAGE  
POLYFOAM/  
DEPRON 5MM



JOIN HERE

JOIN HERE

**F9**

**F10**

FUSELAGE  
POLYFOAM/  
DEPRON 5MM  
2X MIRRORED



**F10**



**F11**

FUSELAGE  
POLYFOAM/  
DEPRON 5MM

**F12**

FUSELAGE  
POLYFOAM/  
DEPRON 5MM

JOIN HERE

JOIN HERE

JOIN HERE

JOIN HERE

**F11**

**F12**

**F13**

FUSELAGE FORMER  
POLYFOAM/  
DEPRON 5MM

**F15**

FUSELAGE FORMER  
POLYFOAM/  
DEPRON 5MM

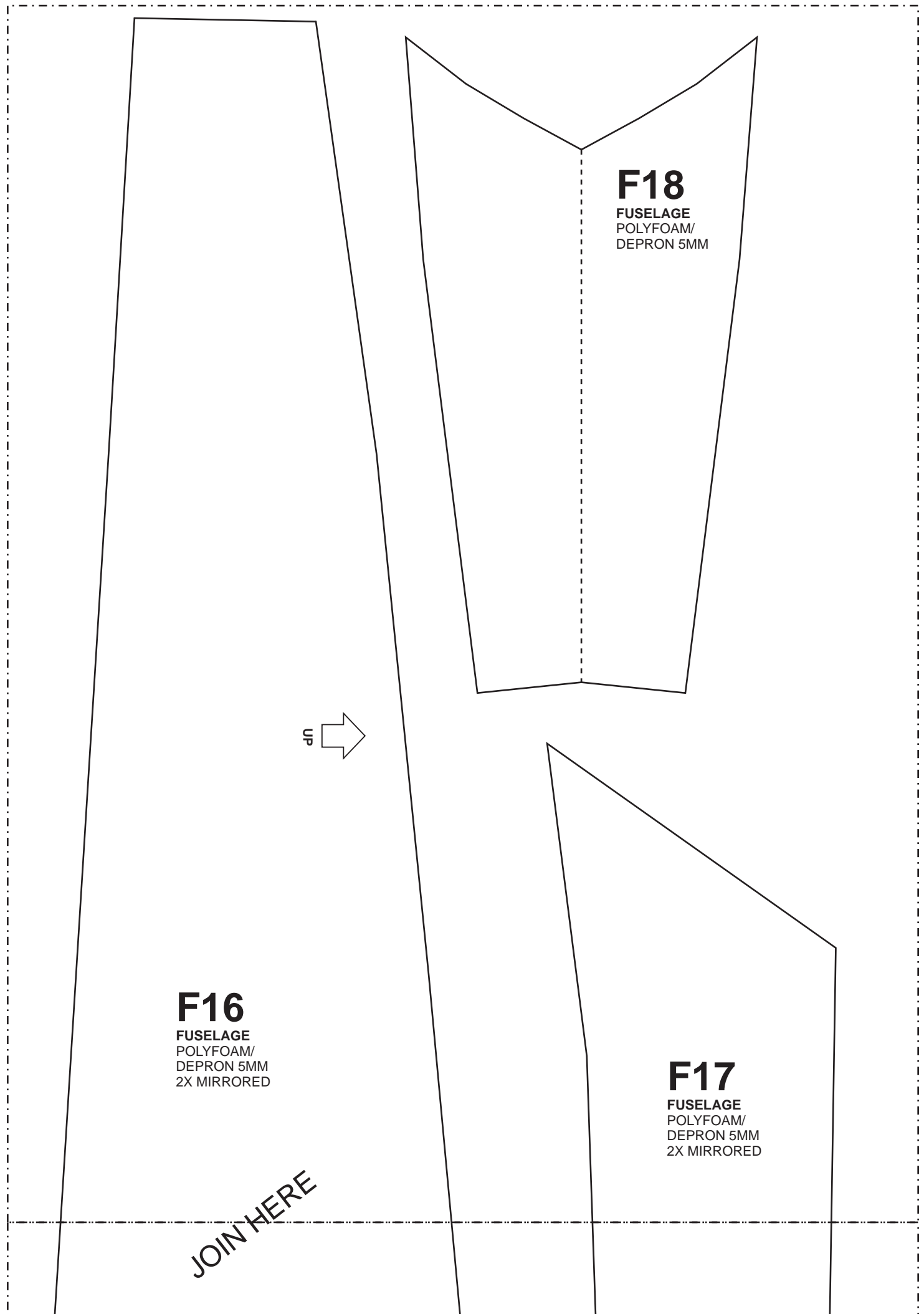

**F16**

FUSELAGE  
POLYFOAM/  
DEPRON 5MM  
2X MIRRORED

JOIN HERE

**F18**

FUSELAGE  
POLYFOAM/  
DEPRON 5MM

**F17**

FUSELAGE  
POLYFOAM/  
DEPRON 5MM  
2X MIRRORED



DEPRON 5MM  
2X MIRRORED

JOIN HERE

F16

F17

FRONT



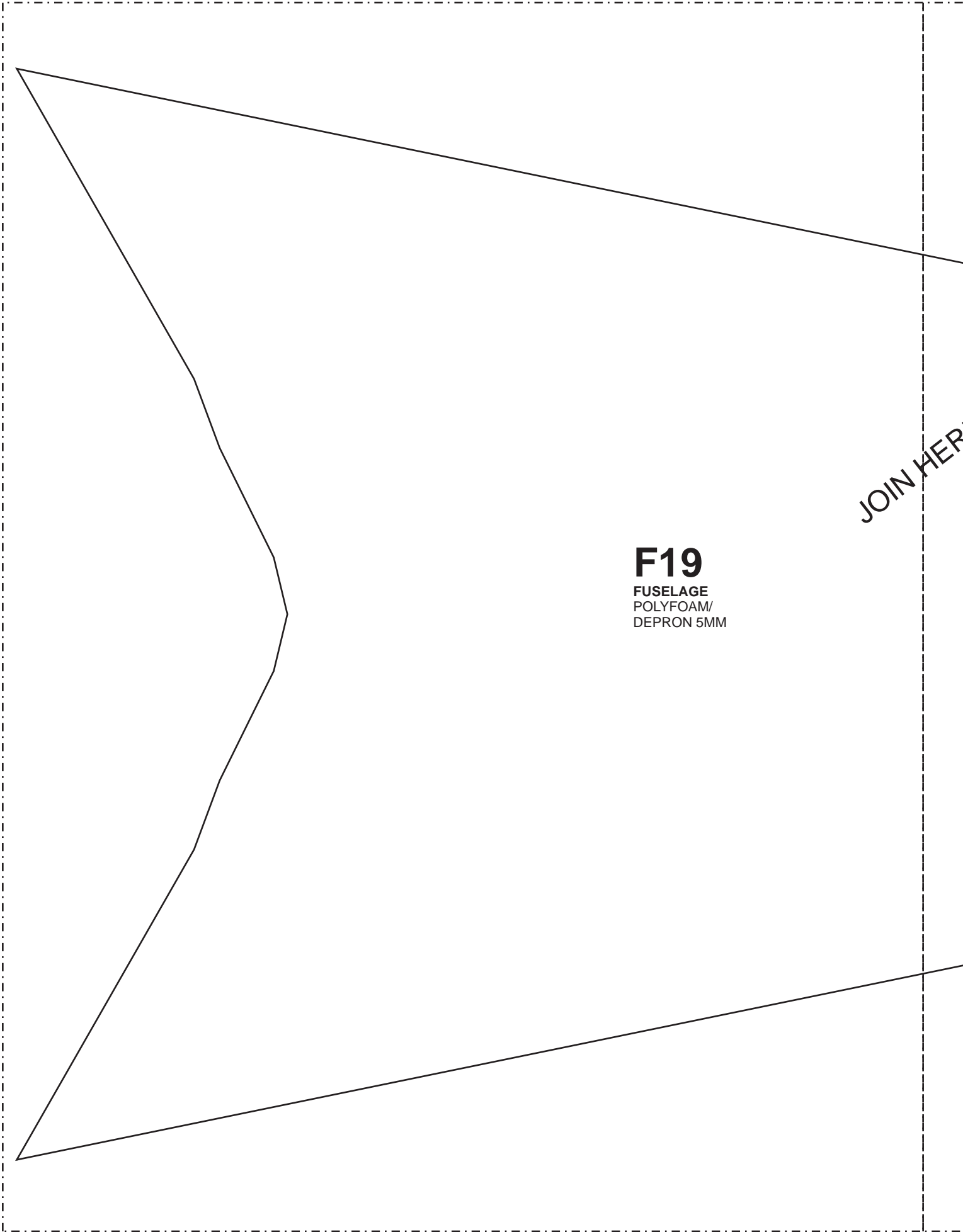

**F19**

FUSELAGE  
POLYFOAM/  
DEPRON 5MM

JOIN HERE

JOIN HERE

**F19**

**F20**  
SIDE VIEW

**F20**  
TOP VIEW

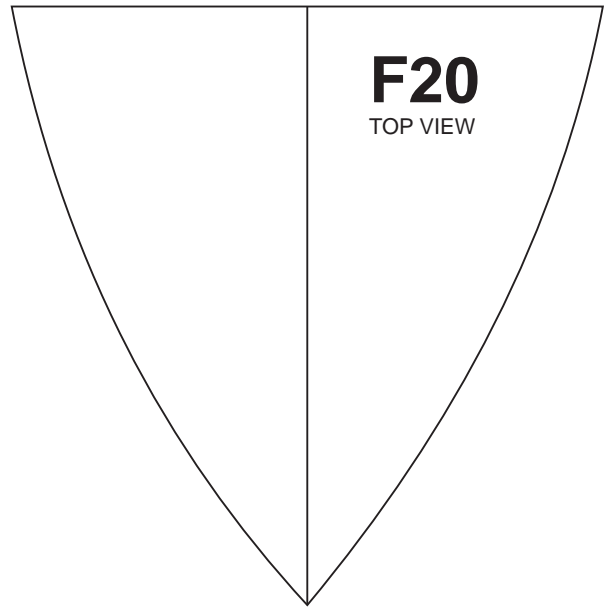
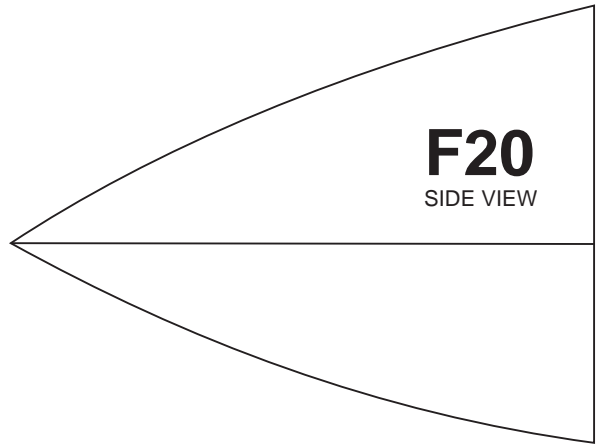

**F21**  
FUSELAGE  
POLYFOAM/  
DEPRON 5MM  
2X MIRRORED

**F26**  
FUSELAGE TAIL  
POLYFOAM/  
DEPRON 5MM  
2X MIRRORED



JOIN HERE



JOIN HERE

F21



UP



FRONT

**F22**

FUSELAGE  
POLYFOAM/  
DEPRON 5MM  
2X MIRRORED





**W2**

WING  
POLYFOAM/  
DEPRON 5MM  
2X MIRRORED

JOIN HERE

**W4**

HORIZONTAL STAB  
POLYFOAM/  
DEPRON 5MM  
2X MIRRORED

JOIN HERE

JOIN HERE

W2

JOIN HERE

JO

JOIN HERE

W2

JOIN HERE

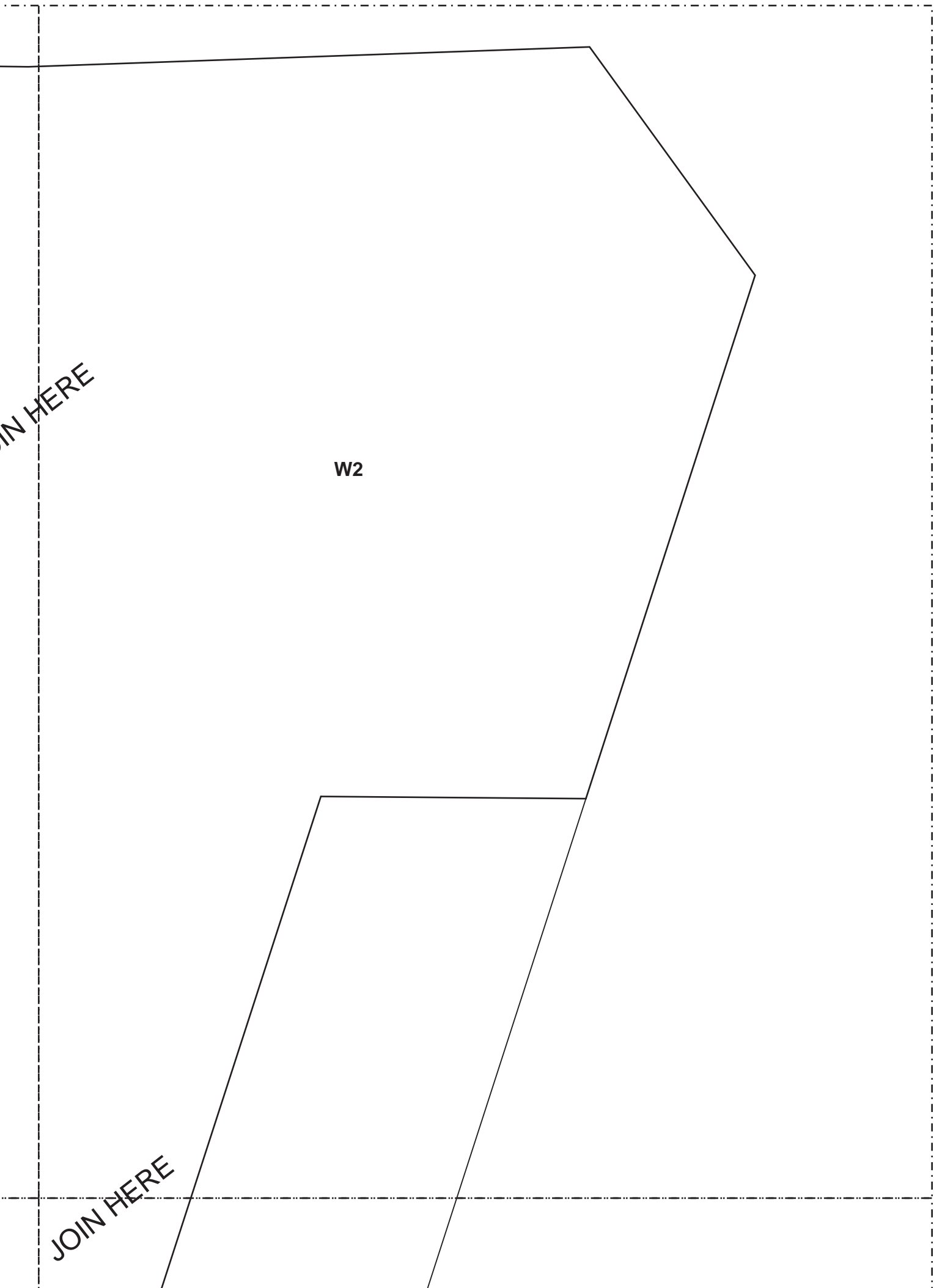

JOIN HERE

JOIN HERE

W2



**F24**  
FUSELAGE TAIL  
POLYFOAM/  
DEPRON 5MM  
2X MIRRORED



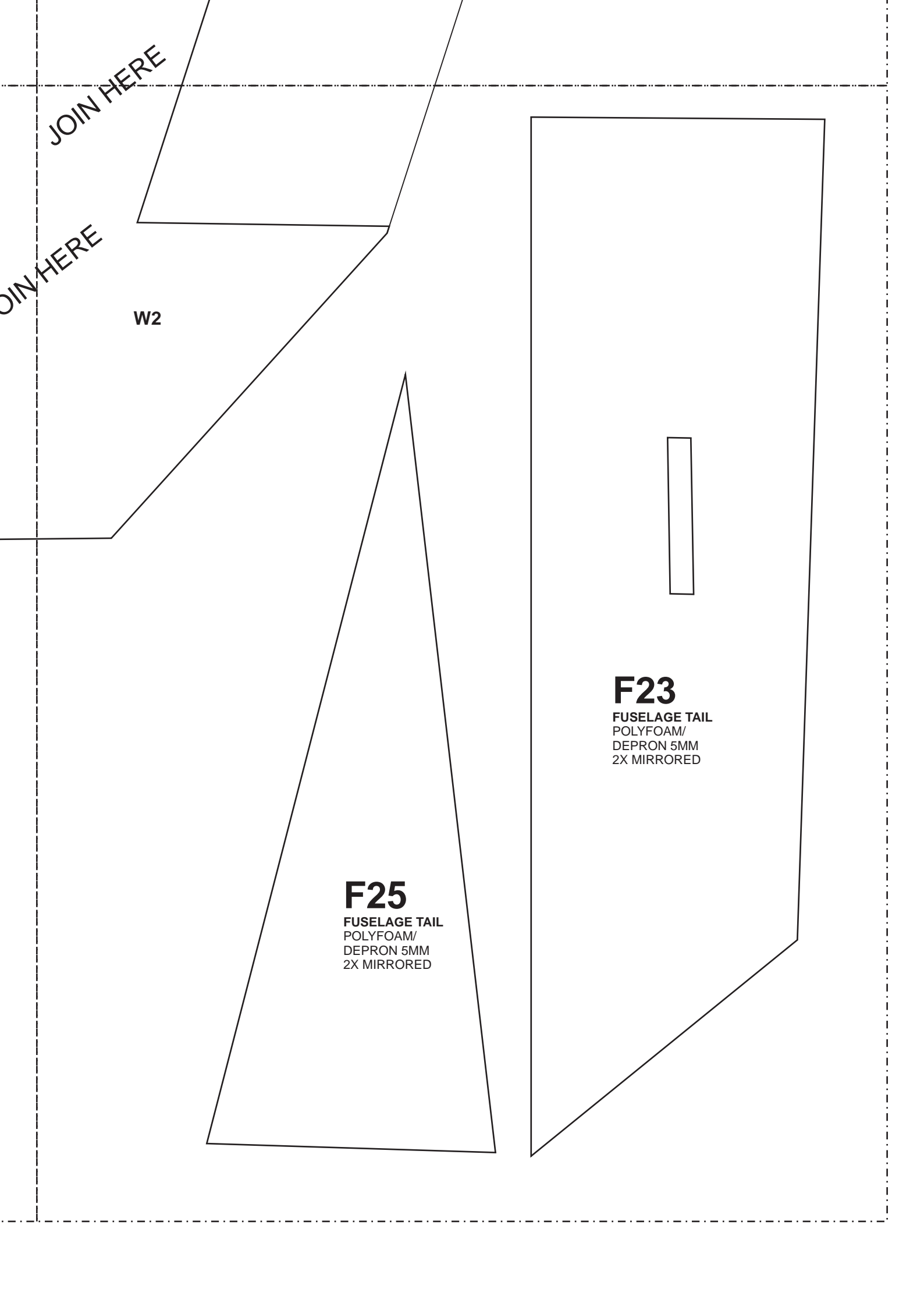

JOIN HERE

JOIN HERE

W2

**F25**

FUSELAGE TAIL  
POLYFOAM/  
DEPRON 5MM  
2X MIRRORED

**F23**

FUSELAGE TAIL  
POLYFOAM/  
DEPRON 5MM  
2X MIRRORED

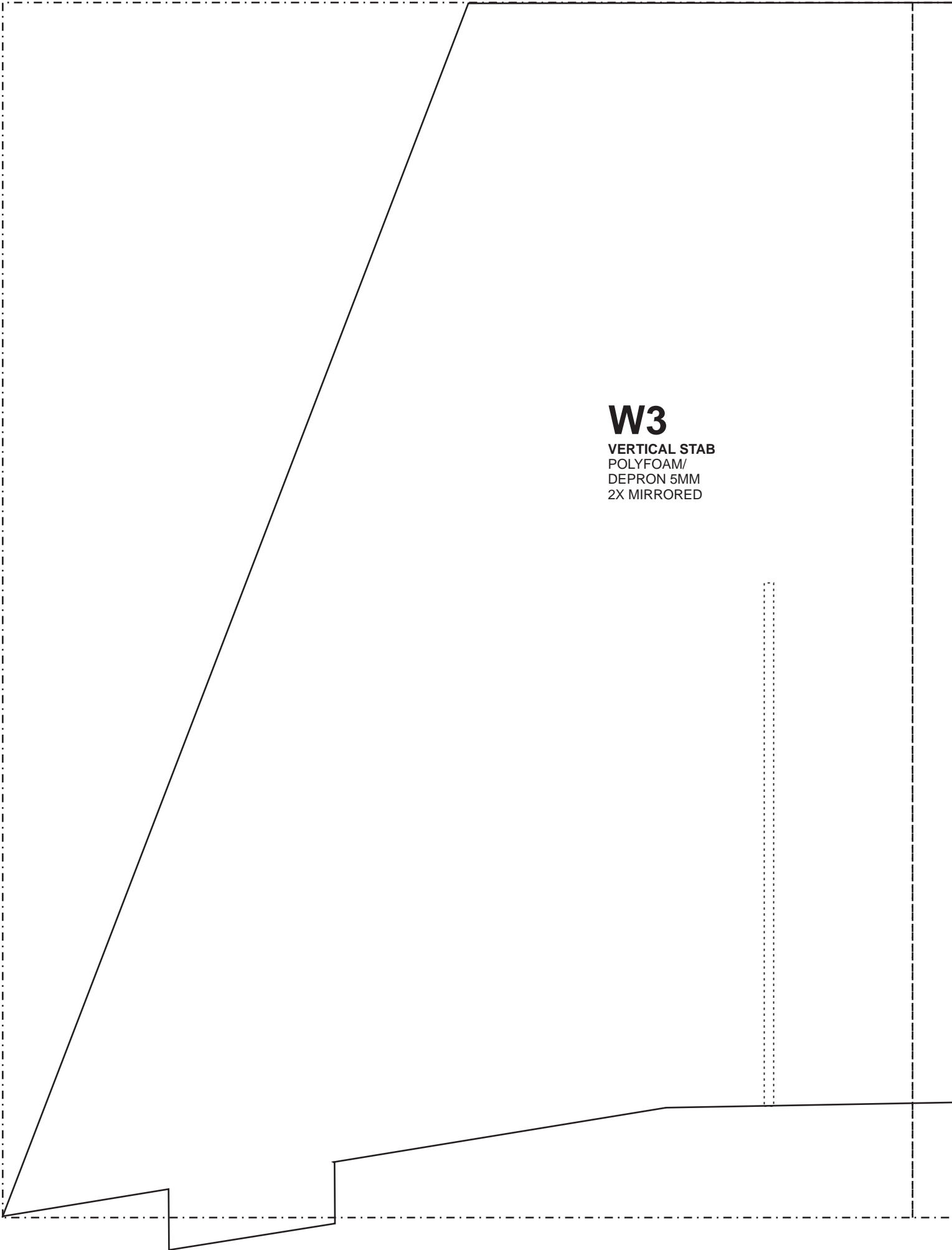

# W3

VERTICAL STAB  
POLYFOAM/  
DEPRON 5MM  
2X MIRRORED

**W5/6**

VERTICAL STAB  
POLYFOAM/  
DEPRON 5MM  
4X MIRRORED



**W3**



**W4**

**ELEVATOR**  
POLYFOAM/  
DEPRON 5MM  
2X MIRRORED



