

Model : 44/2023

HC-130H Hercules

3000mm

- Specs :**
1. Wingspan 3000 mm / 118 inches
 2. Flying weight - 4800 grams / 169.3 oz
 3. Wing loading - 47.8 gram/dm² - 15.7 oz/sq.ft
 4. Wing cube loading - 4.8
 5. Wing Area - 100.43 dm² / 1567 sq.in
 6. CG - 11.5 cm / 4.5 inch from leading edge

- Materials :**
1. 5mm Foamboard/ Depron Polyfoam
 2. 2mm Plywood
 3. hot glue, UHU glue, CA glue
 4. wax paper
 5. PLA Filament

- Electronics for test**
- 4x DXW 3536 1200kv
 - 2x 50A ESC Hobbywing Skywalker
 - 2x 50A ESC Aerostar
 - 2x Battery Lipo 3S 2200mah
 - 5 x 9 gram servo (metal micro servo)
 - 1 x standard servo (steering)

- Prop :**
- 100x4 inch props
 - 58mm 3D printed spinners

- Transmitter**
- Jumper T16 + BetaFPV Express LRS TX module
 - 5 ch BetaFPV Express LRS RX

- Build Instructions :**
1. paper-repika.com
 2. youtube channel - Julius Perdana

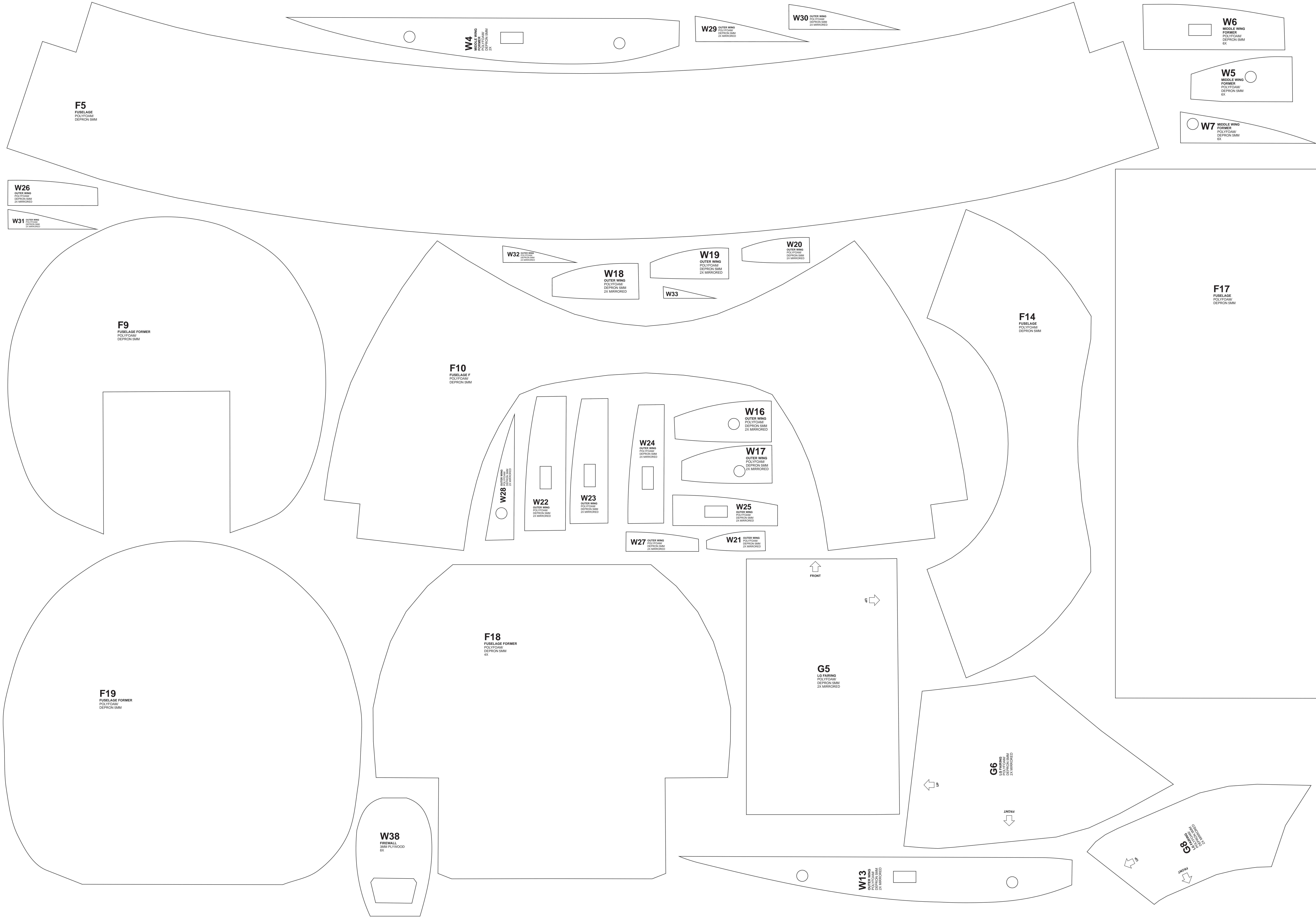

F5
FUSELAGE
POLYFOAM/
DEPRON 5MM

W4
MIDDLE WING
FORMER
POLYFOAM/
DEPRON 5MM
2X

W29 OUTER WING
POLYFOAM/
DEPRON 5MM
2X MIRRORRED

W30 OUTER WING
POLYFOAM/
DEPRON 5MM
2X MIRRORRED

W6
MIDDLE WING
FORMER
POLYFOAM/
DEPRON 5MM
2X

W5
MIDDLE WING
FORMER
POLYFOAM/
DEPRON 5MM
2X

W7 MIDDLE WING
FORMER
POLYFOAM/
DEPRON 5MM
2X

W26 OUTER WING
POLYFOAM/
DEPRON 5MM
2X MIRRORRED

W31 OUTER WING
POLYFOAM/
DEPRON 5MM
2X MIRRORRED

F9
FUSELAGE FORMER
POLYFOAM/
DEPRON 5MM

W32 OUTER WING
POLYFOAM/
DEPRON 5MM
2X MIRRORRED

W18
OUTER WING
POLYFOAM/
DEPRON 5MM
2X MIRRORRED

W19
OUTER WING
POLYFOAM/
DEPRON 5MM
2X MIRRORRED

W20 OUTER WING
POLYFOAM/
DEPRON 5MM
2X MIRRORRED

F17
FUSELAGE
POLYFOAM/
DEPRON 5MM

F14
FUSELAGE
POLYFOAM/
DEPRON 5MM

F10
FUSELAGE F
POLYFOAM/
DEPRON 5MM

W16
OUTER WING
POLYFOAM/
DEPRON 5MM
2X MIRRORRED

W24
OUTER WING
POLYFOAM/
DEPRON 5MM
2X MIRRORRED

W17
OUTER WING
POLYFOAM/
DEPRON 5MM
2X MIRRORRED

W28 OUTER WING
POLYFOAM/
DEPRON 5MM
2X MIRRORRED

W22
OUTER WING
POLYFOAM/
DEPRON 5MM
2X MIRRORRED

W23
OUTER WING
POLYFOAM/
DEPRON 5MM
2X MIRRORRED

W25
OUTER WING
POLYFOAM/
DEPRON 5MM
2X MIRRORRED

W27 OUTER WING
POLYFOAM/
DEPRON 5MM
2X MIRRORRED

W21 OUTER WING
POLYFOAM/
DEPRON 5MM
2X MIRRORRED

FRONT

FRONT

G5
LO FAIRING
POLYFOAM/
DEPRON 5MM
2X MIRRORRED

G6
LO FAIRING
POLYFOAM/
DEPRON 5MM
2X MIRRORRED

FRONT

F18
FUSELAGE FORMER
POLYFOAM/
DEPRON 5MM
4X

F19
FUSELAGE FORMER
POLYFOAM/
DEPRON 5MM

W38
FIREWALL
3MM PLYWOOD
8X

W13
OUTER WING
POLYFOAM/
DEPRON 5MM
2X MIRRORRED

G8
LO FAIRING
POLYFOAM/
DEPRON 5MM
2X MIRRORRED

FRONT



F16
FUSELAGE
POLYFOAM/
DEPRON 5MM

F23
FUSELAGE
POLYFOAM/
DEPRON 5MM

F25
FUSELAGE
POLYFOAM/
DEPRON 5MM

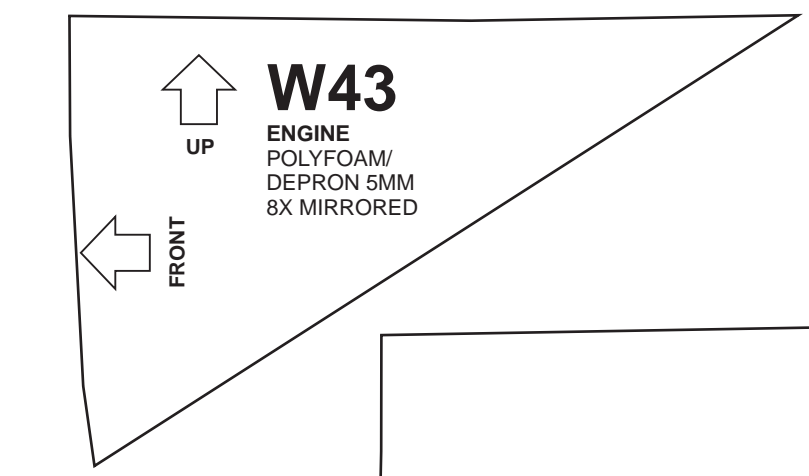
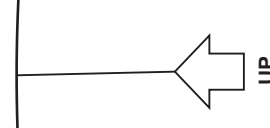

W43
ENGINE
POLYFOAM/
DEPRON 5MM
5X MIRRORRED

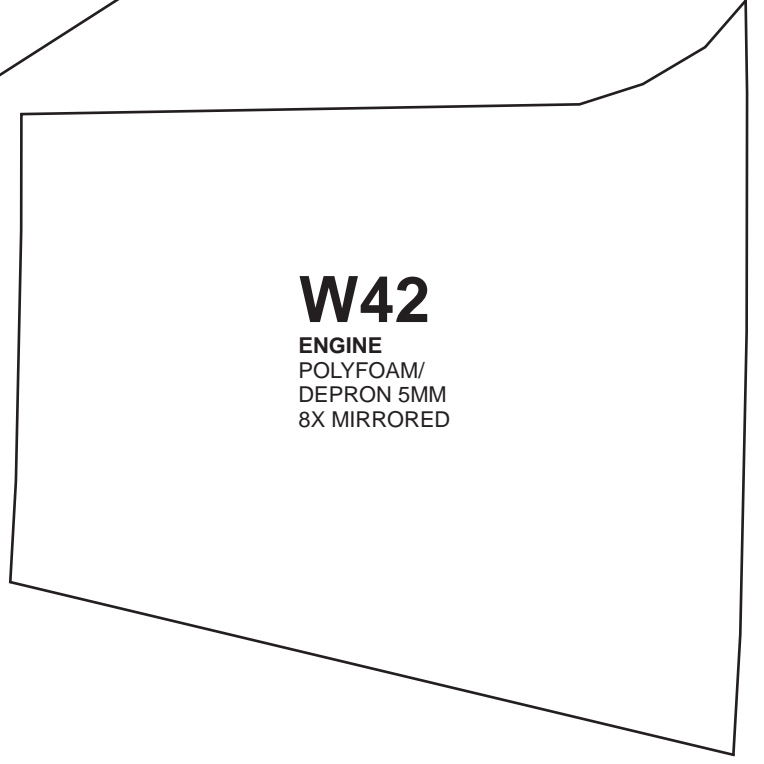

W42
ENGINE
POLYFOAM/
DEPRON 5MM
5X MIRRORRED

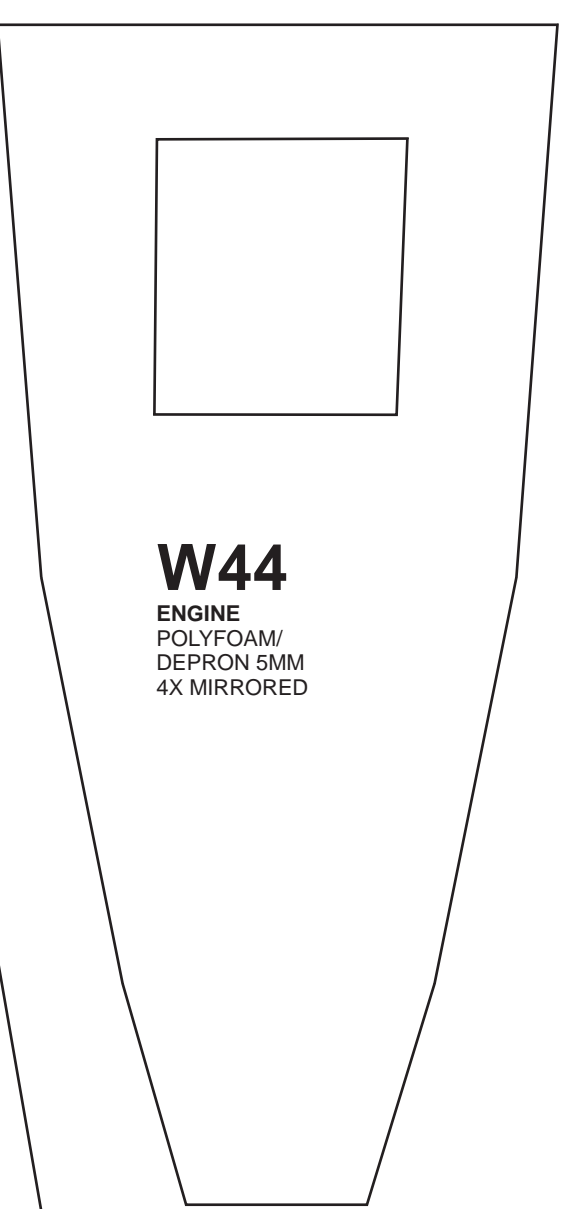

W44
ENGINE
POLYFOAM/
DEPRON 5MM
4X MIRRORRED

S6
RUDDER
POLYFOAM/
DEPRON 5MM
2X

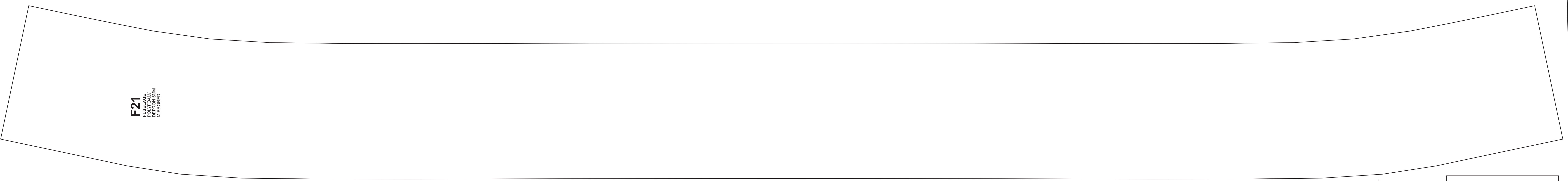

F21
FUSELAGE
POLYFOAM/
DEPRON 5MM
MIRRORRED

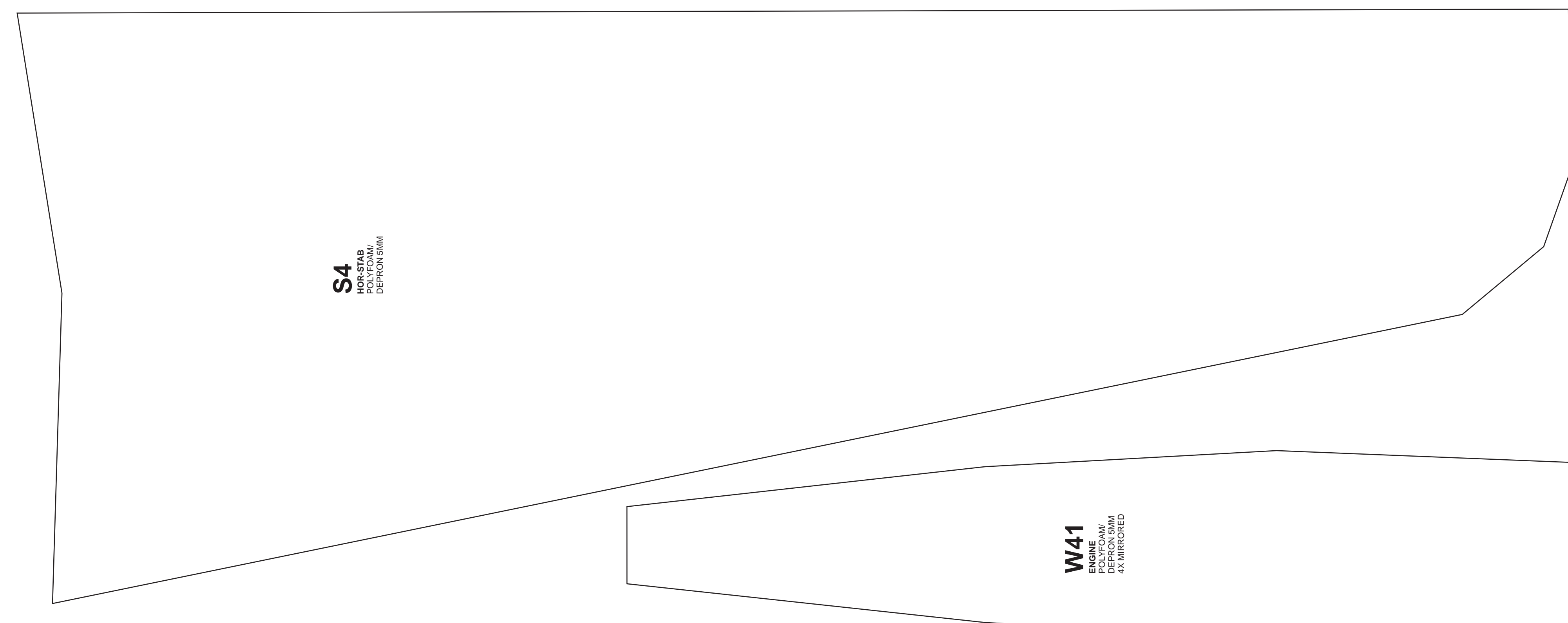

S4
MAIN STRUT
POLYFOAM/
DEPRON 5MM

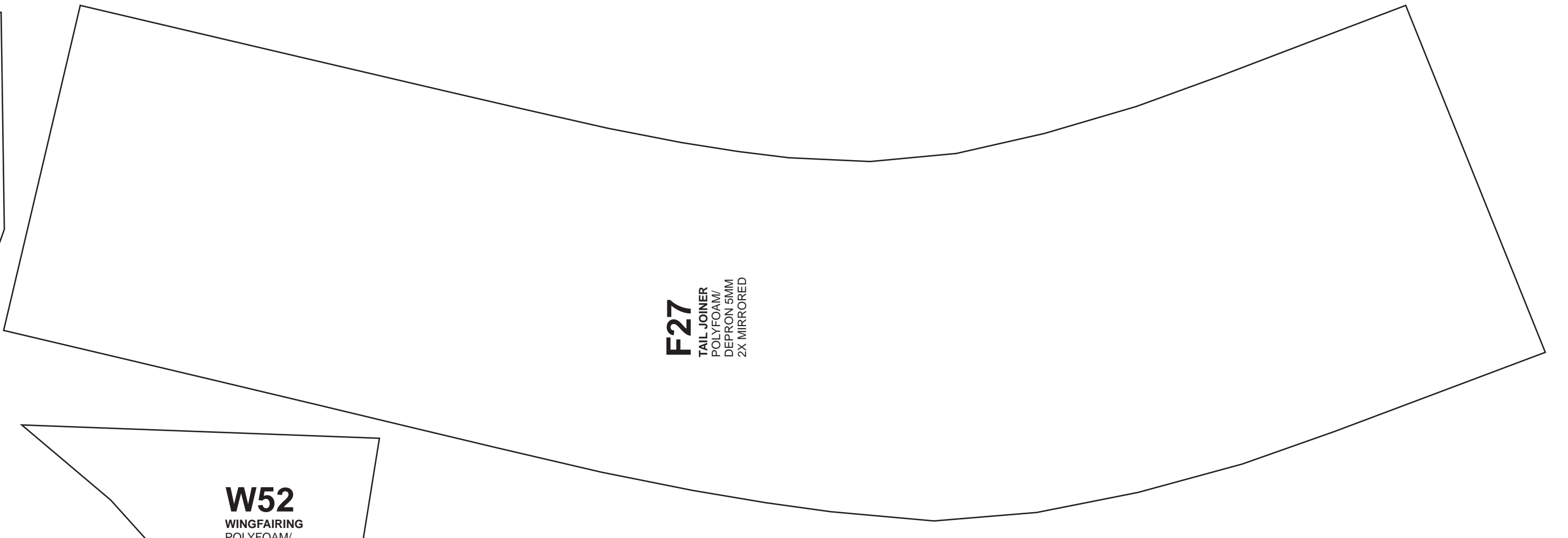

F27
WING
POLYFOAM/
DEPRON 5MM
2X MIRRORRED

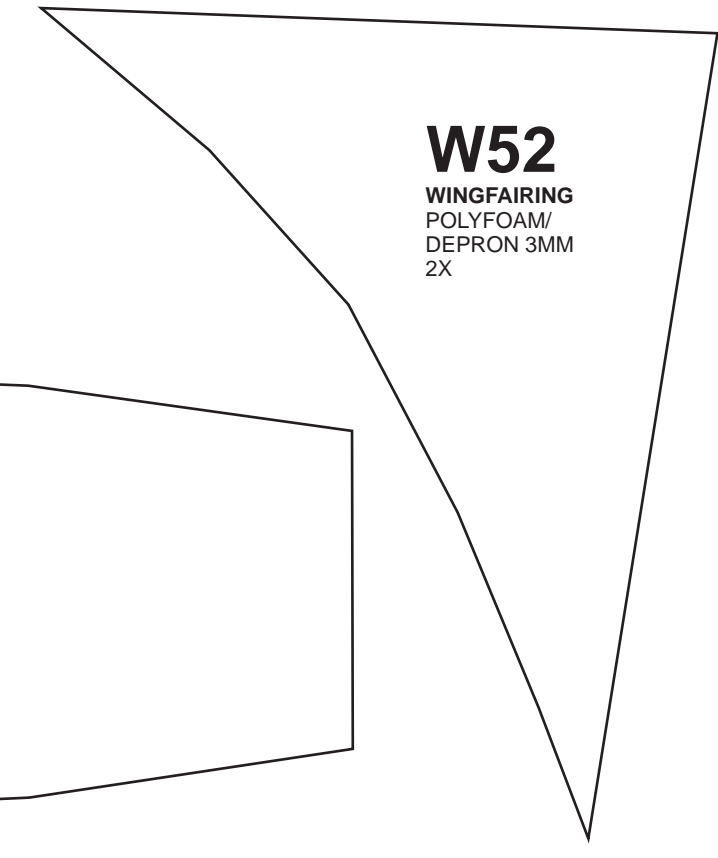

W52
WINGFAIRING
POLYFOAM/
DEPRON 5MM
2X

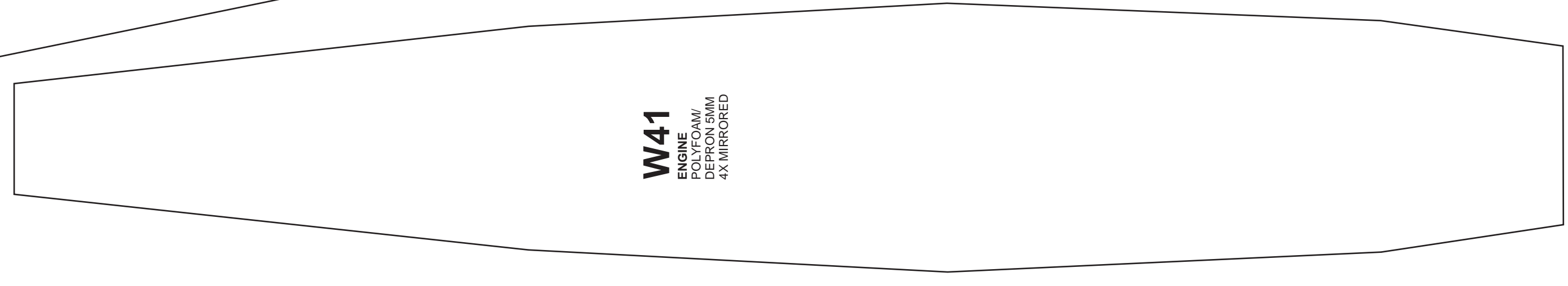

W41
ENGINE
POLYFOAM/
DEPRON 5MM
4X MIRRORRED



W48
WINGTIP
POLYFOAM/
DEPRON 5MM

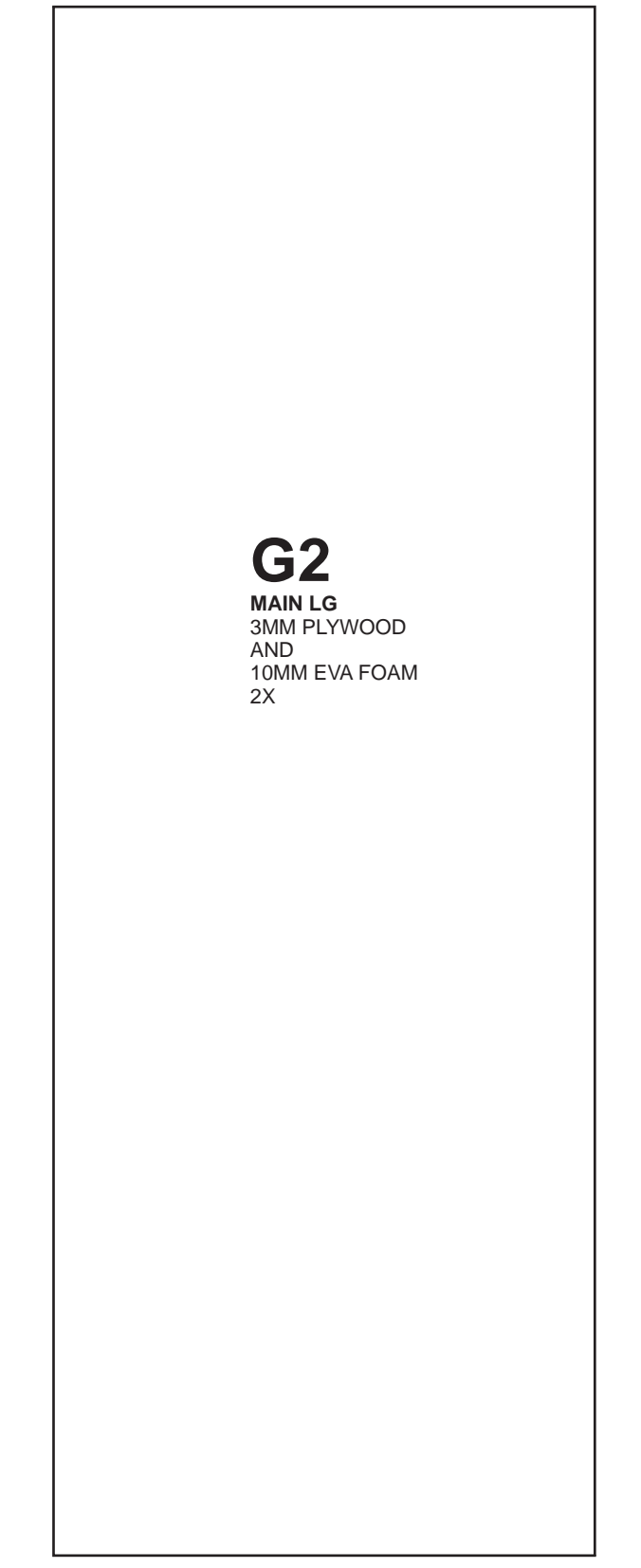

G2
MAIN LG
5MM PLYWOOD
AND
10MM EVA FOAM
2X

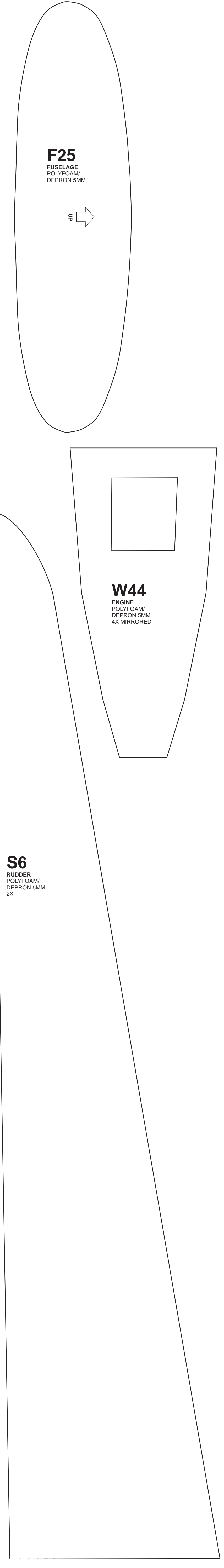

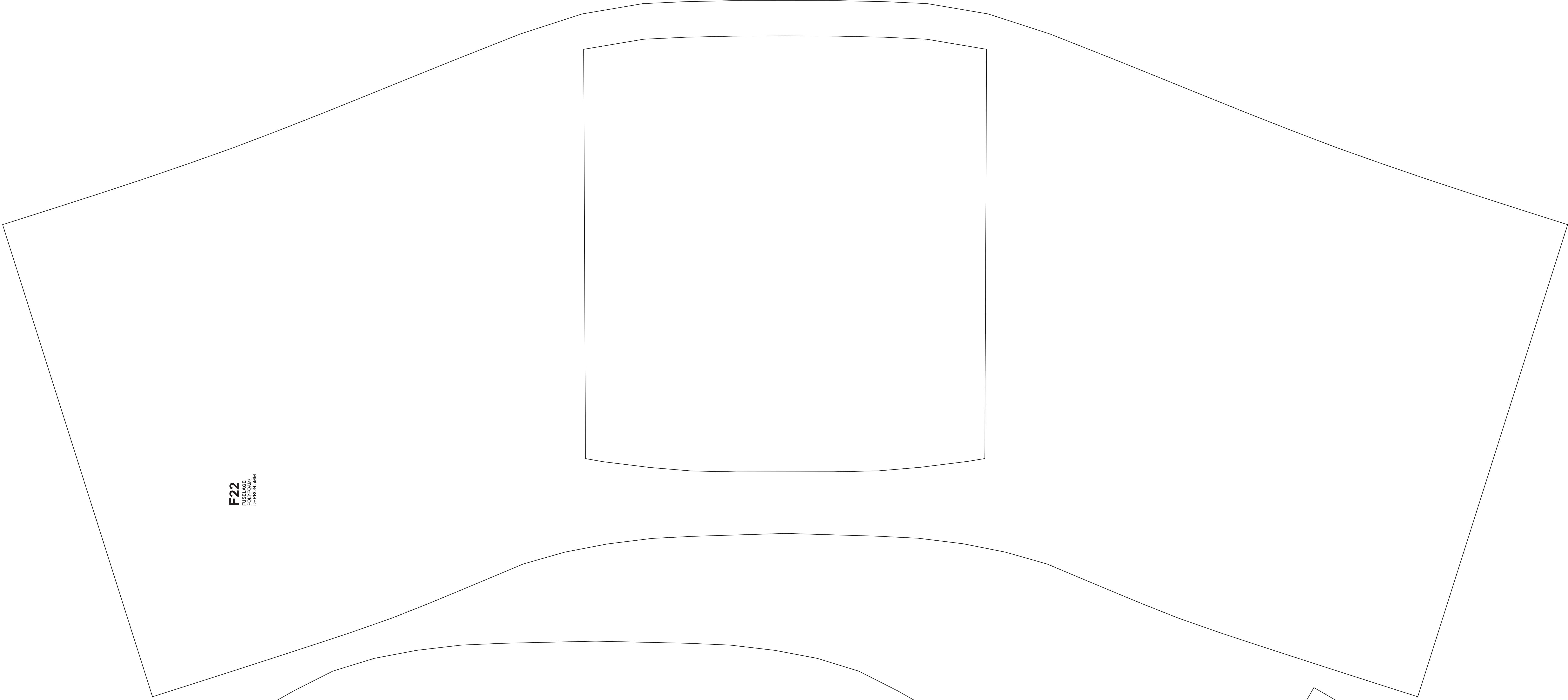

F22
ENGINE
POLYFOAM
DEPRON 5MM
4X MIRRORRED

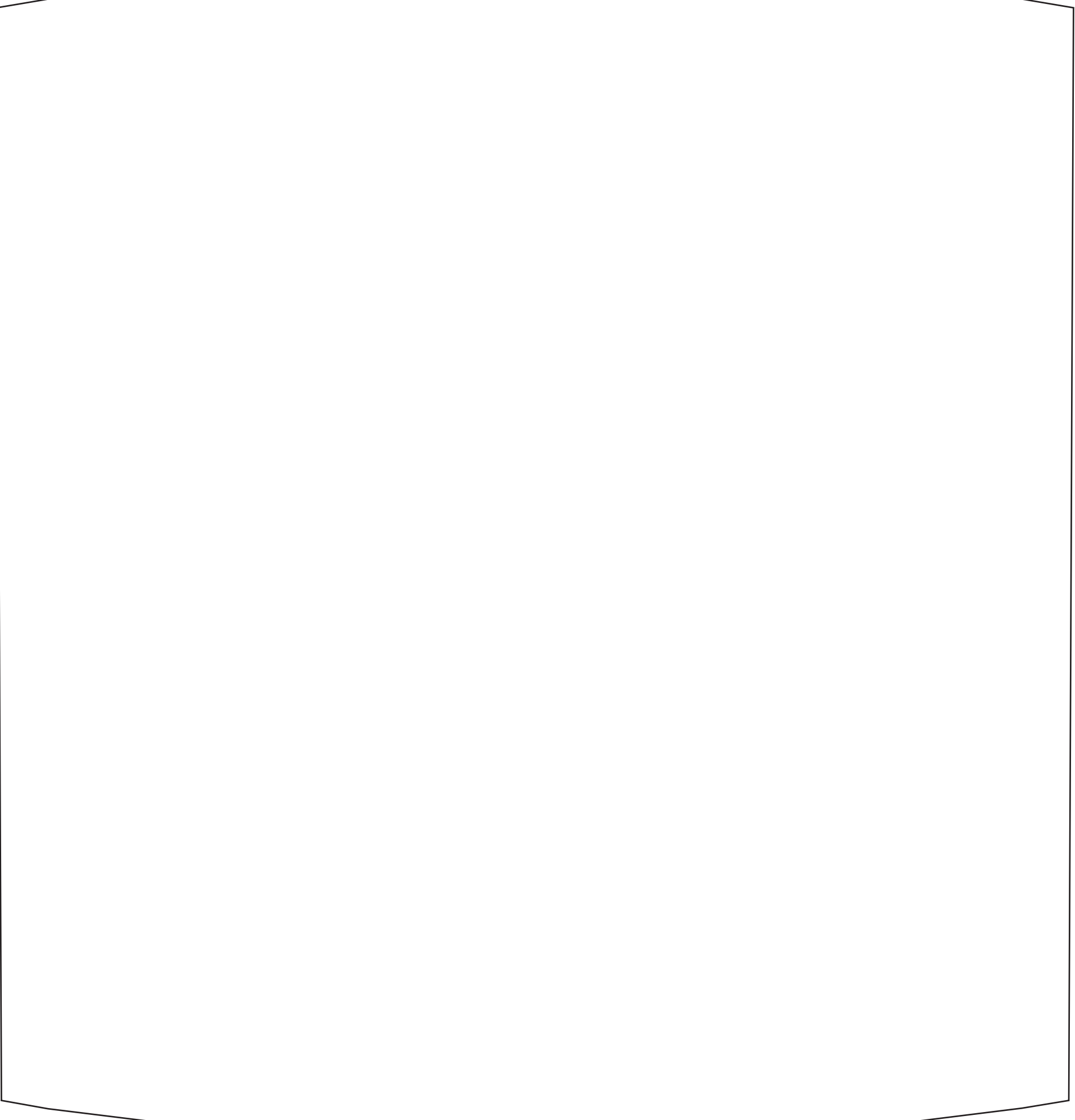

S7
HOR-STAB
POLYFOAM
DEPRON 5MM
2X MIRRORRED

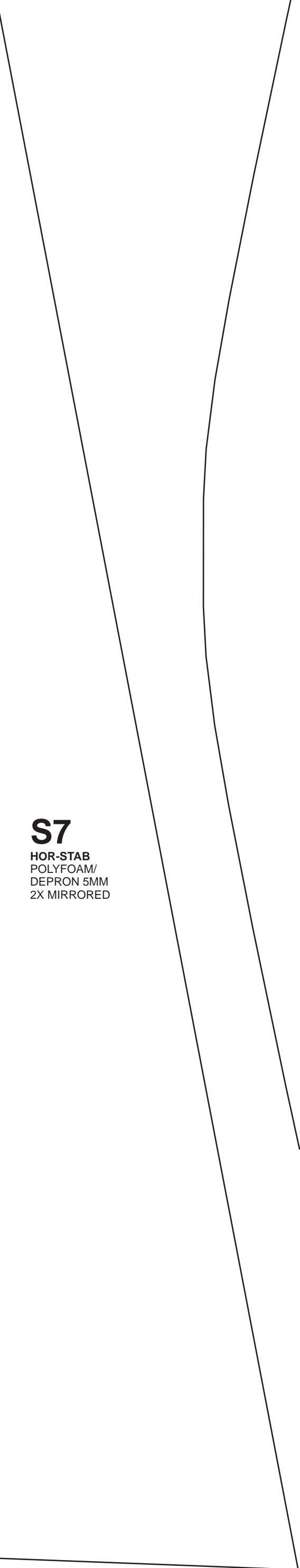

W39
ENGINE
POLYFOAM
DEPRON 5MM
4X MIRRORRED

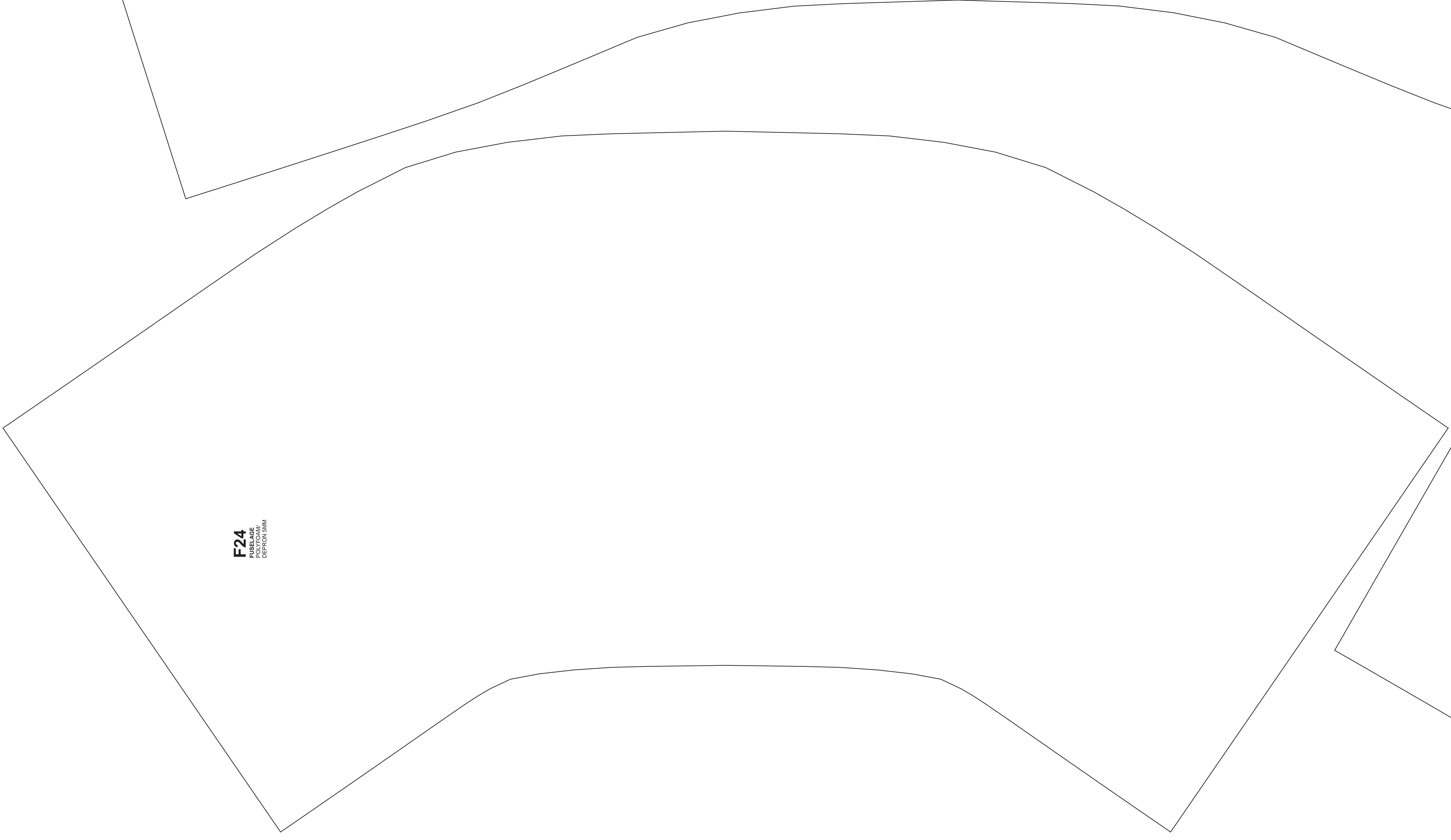
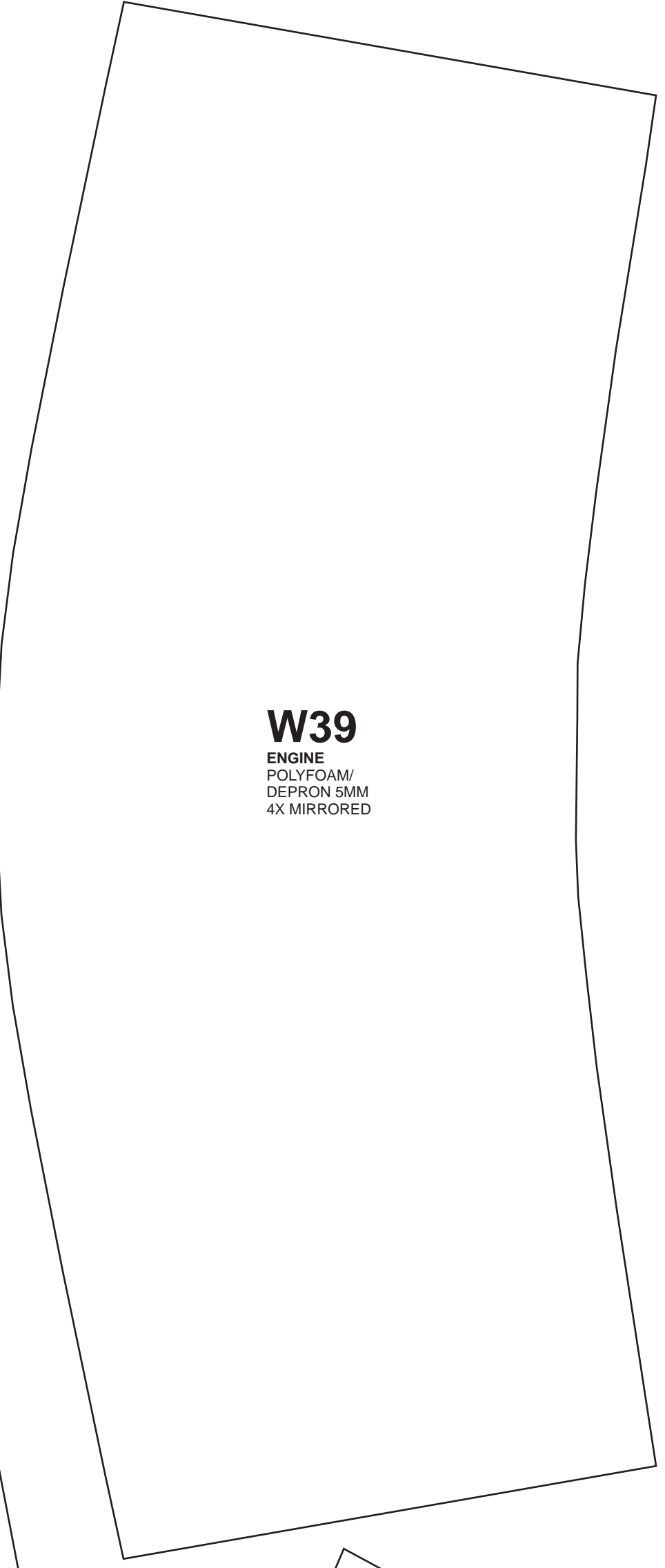

F24
ENGINE
POLYFOAM
DEPRON 5MM
4X MIRRORRED

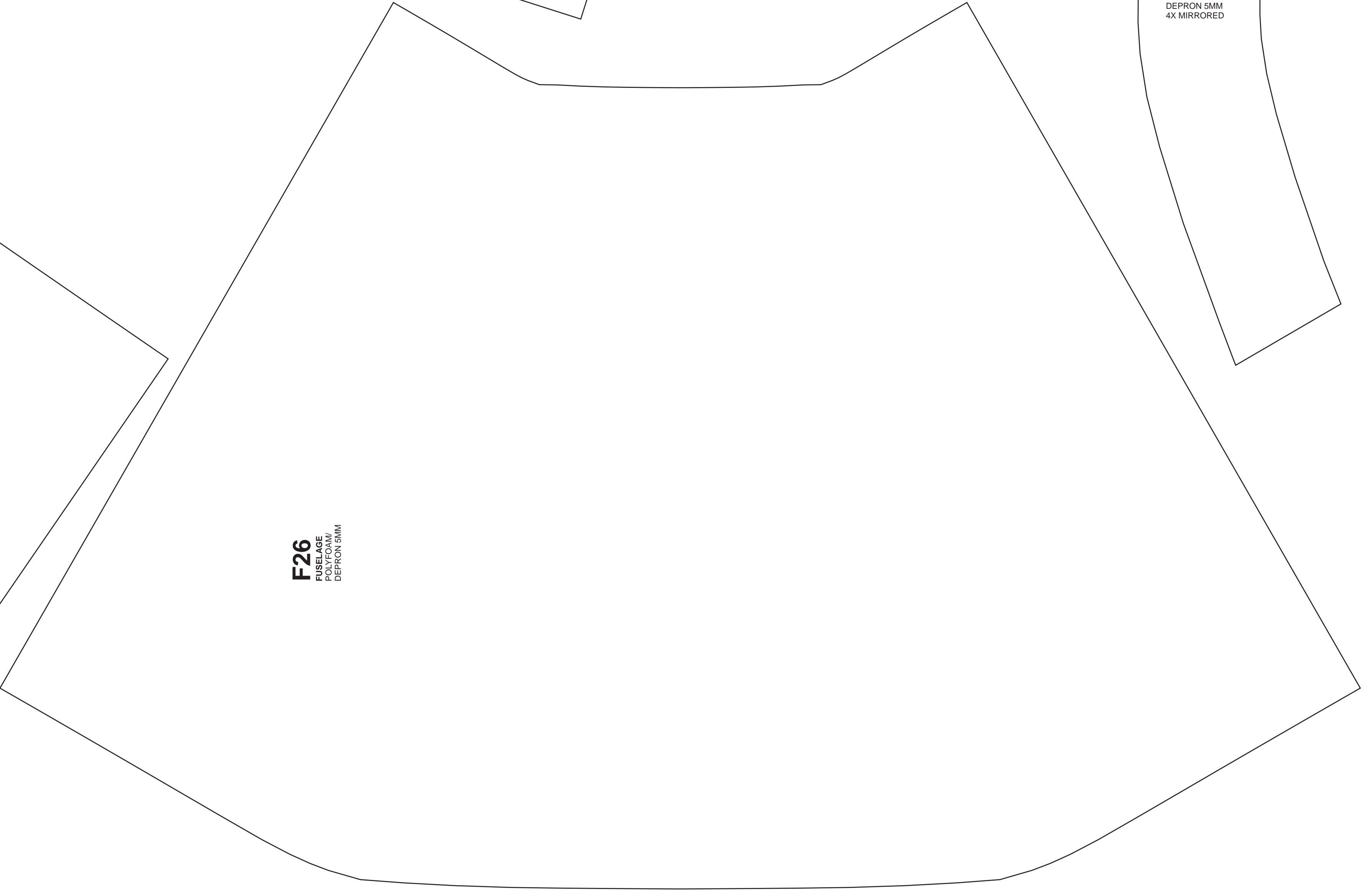

F26
ENGINE
POLYFOAM
DEPRON 5MM
4X MIRRORRED

W40
ENGINE
POLYFOAM
DEPRON 5MM
4X MIRRORRED

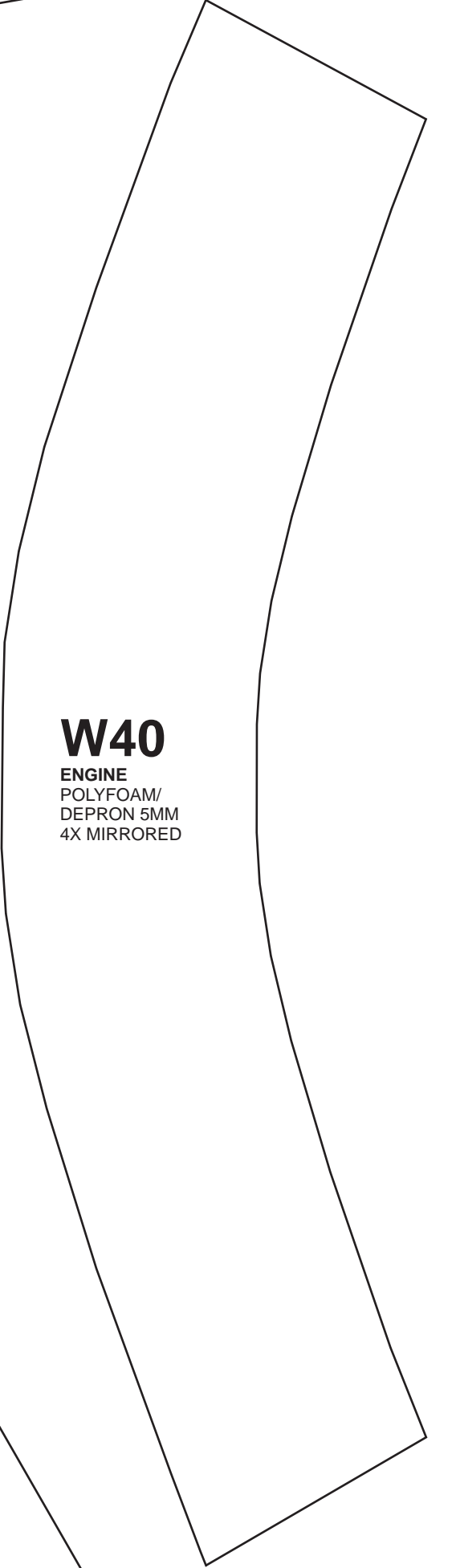

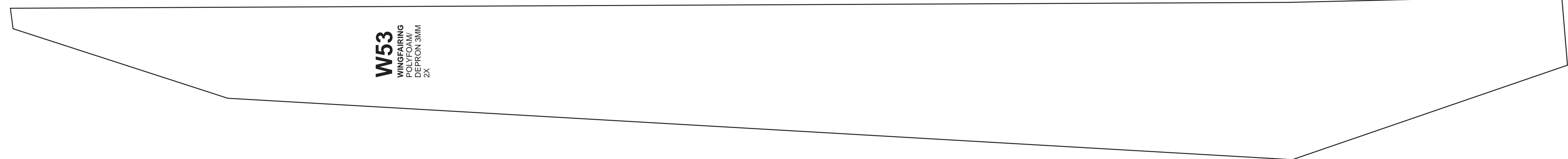
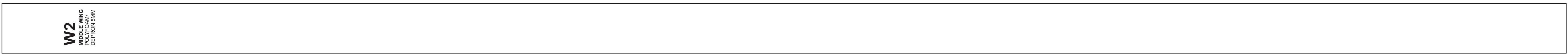
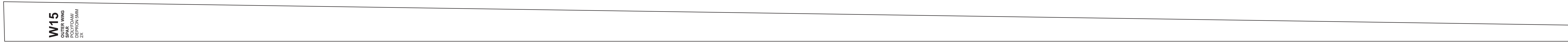
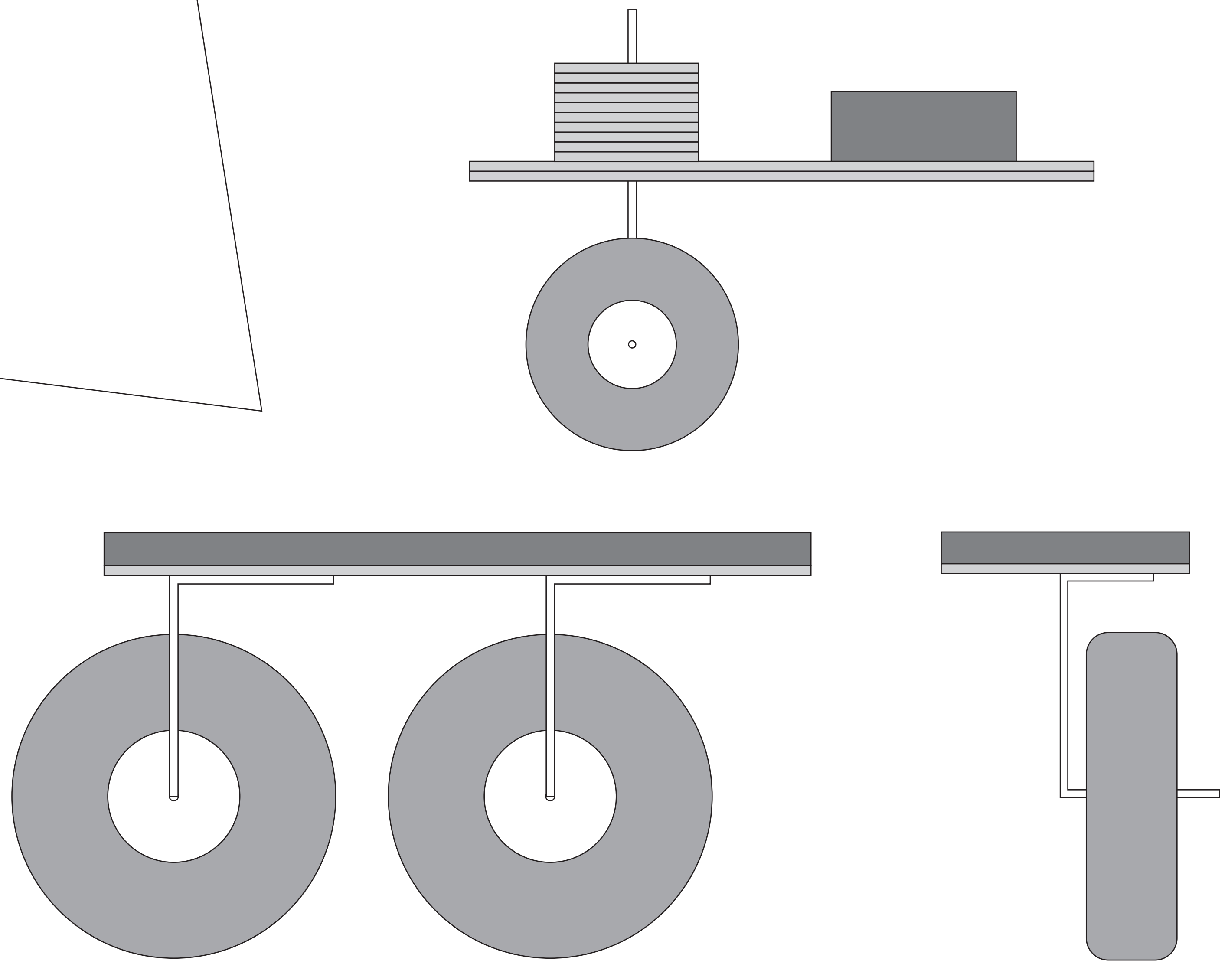
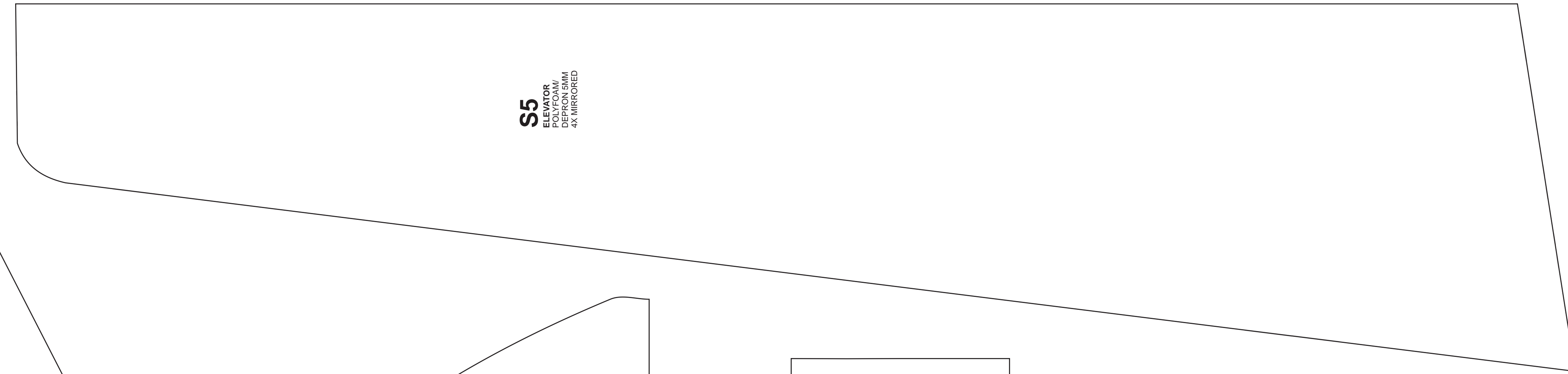
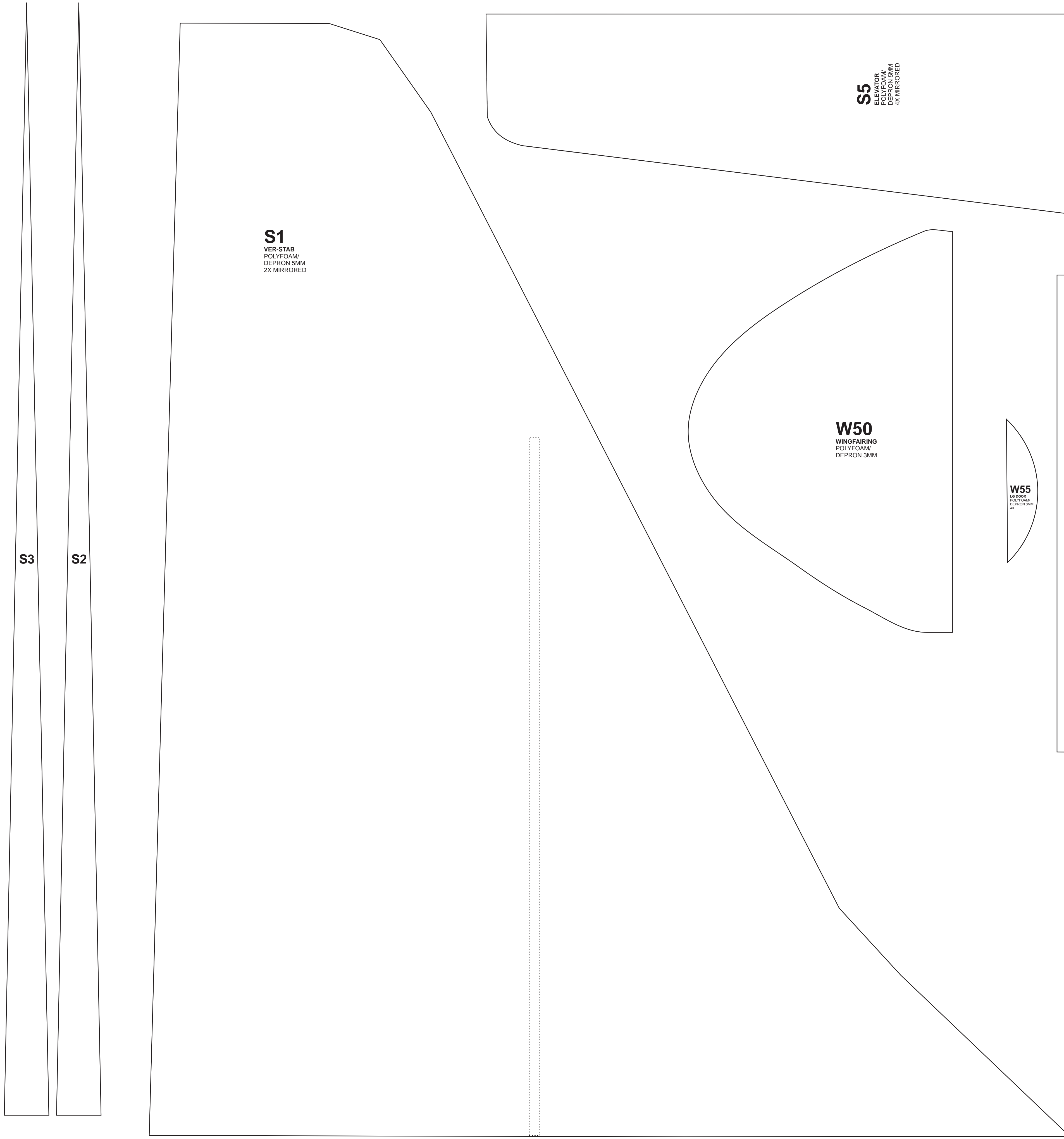

W1
MIDDLE WING
POLYFOAM
DEFRON 500J

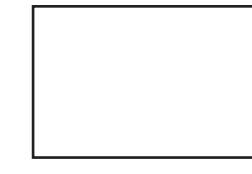
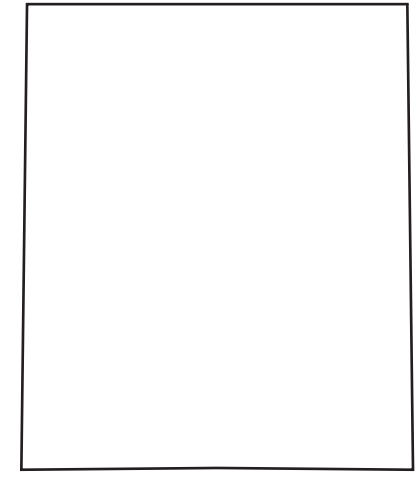
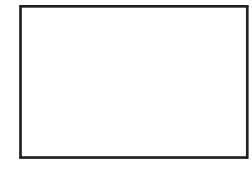

W12
LEFT WING
POLYFOAM
ZUMMERBILD

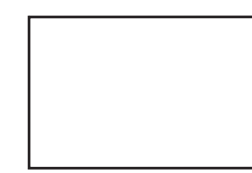
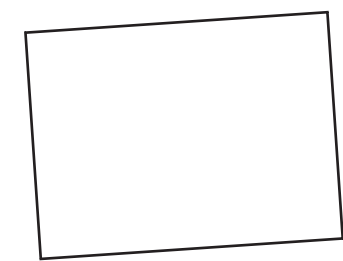

W36
MIDDLE WING
DEPT/PCN DATA

W37
OUTER WING
DEPT/PCN DATA
2X REPRODUCED