



Model : 09/2020



BOEING 737-300

1800mm - PART 1

Specs :

1. Wingspan 1800mm / 71 inches
2. Flying weight : target below 2000 grams/ 70.5 oz
3. Wing loading : -
4. Wing cube loading : -
5. Wing Area : -
6. CG : -
7. 1 set of Servoless Retractable Landing Gear

Electronics

- 2X Turnigy 2826 2200kv brushless motor
- 2X ESC 40A
- Battery Lipo 2X 3S 2200 - 3S 5200mah - 2X Li-ion 3S 3300 mah
- 3 plastic gear 9 gram servos
- 3 metal gear 9 gram servos
- Propeller : 7x5 APC

Materials :

1. 5mm & 10mm Depron/ Polyfoam
2. 3mm Plywood
4. 0.3mm Mica Plastic
5. hot glue + CA glue + UHU glue
6. white packing tape

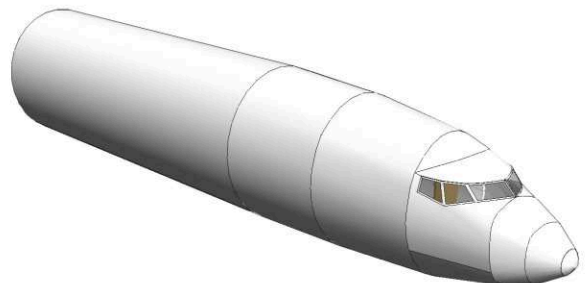

Build Instructions :

1. paper-replika.com
2. youtube channel : Julius Perdana

F1

FUSELAGE
POLYFOAM/ DEPRON 5MM

JOIN HERE

JOIN HERE

JOIN HERE

F1

JOIN HERE

JOIN HERE

JOIN HERE

JOIN HERE

F1

JOIN HERE

HERE

JOIN HERE

F1

F3

FUSELAGE
POLYFOAM/ DEPRON 5MM

JOIN HERE

JOIN HERE

JOIN HERE

F1

JOIN HER

JOIN HERE

JOIN HERE

F1

JOIN HERE

JOIN HERE

JOIN HERE

JOIN HERE

F1

JOIN HERE

JOIN HERE

JOIN HERE

JOIN HERE

JOIN HERE

F1

F3

JOIN HERE

JOIN HERE

JOIN HERE

JOIN HERE

F1

JOIN HE

LANDING GEAR DOOR MECHANISM

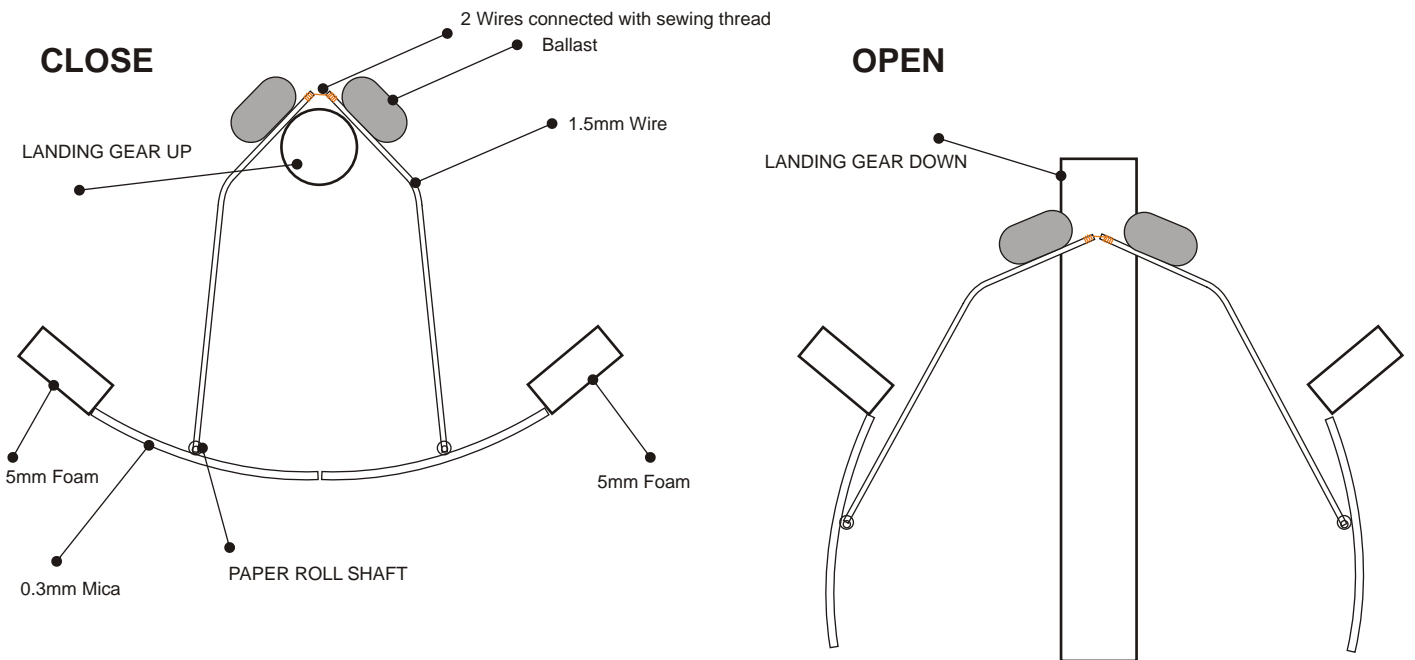

JOIN HERE

JOIN HERE

JOIN HERE

F1

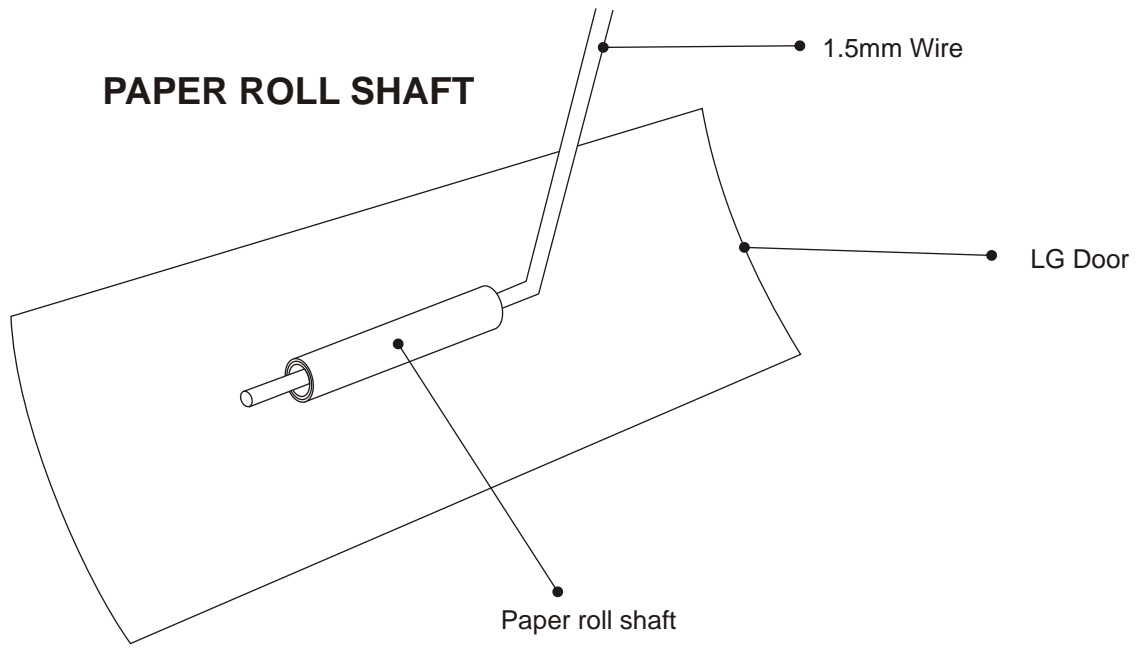

JOIN HERE

JOIN HERE

JOIN HERE

F1

FIXED LANDING GEAR

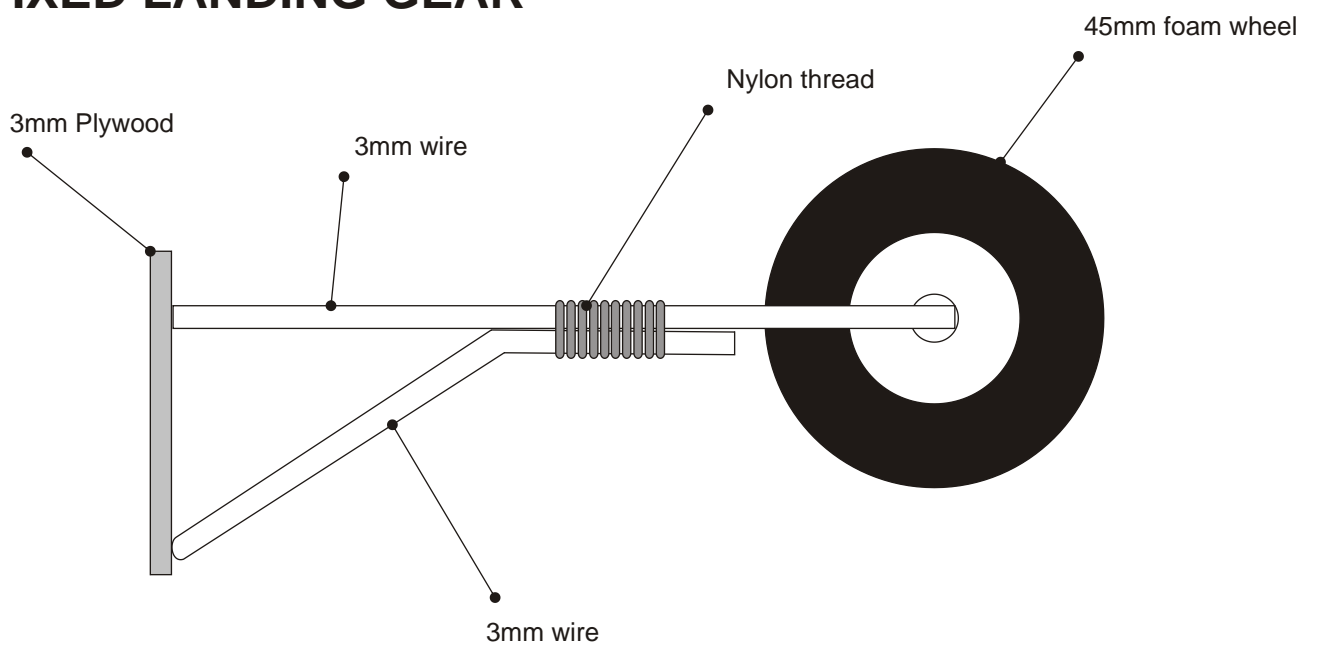

JOIN HERE

JOIN HERE

JOIN HERE

F1

F3

FIXED LANDING GEAR

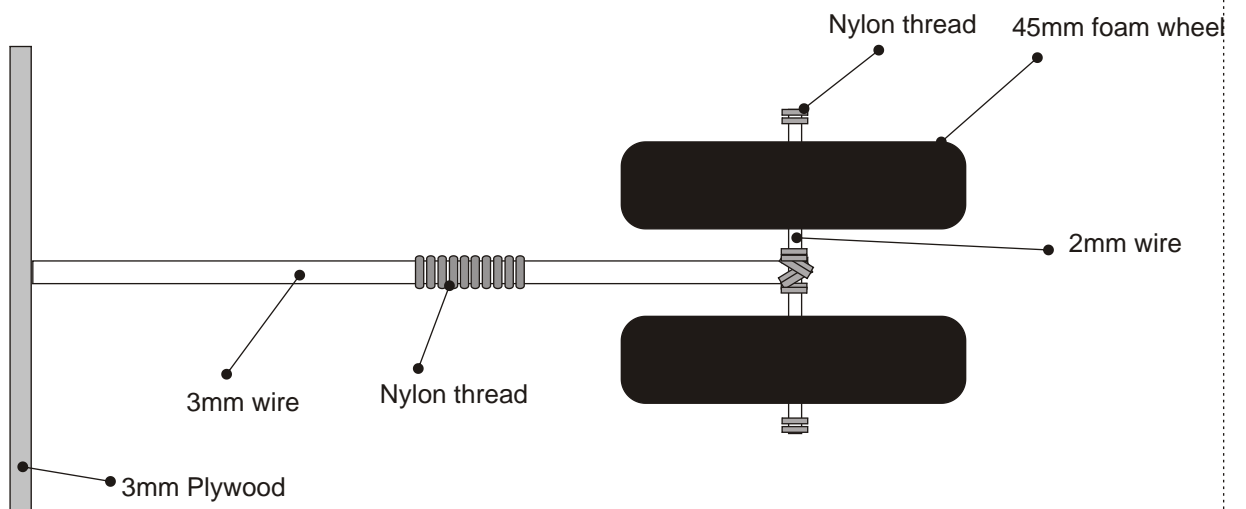

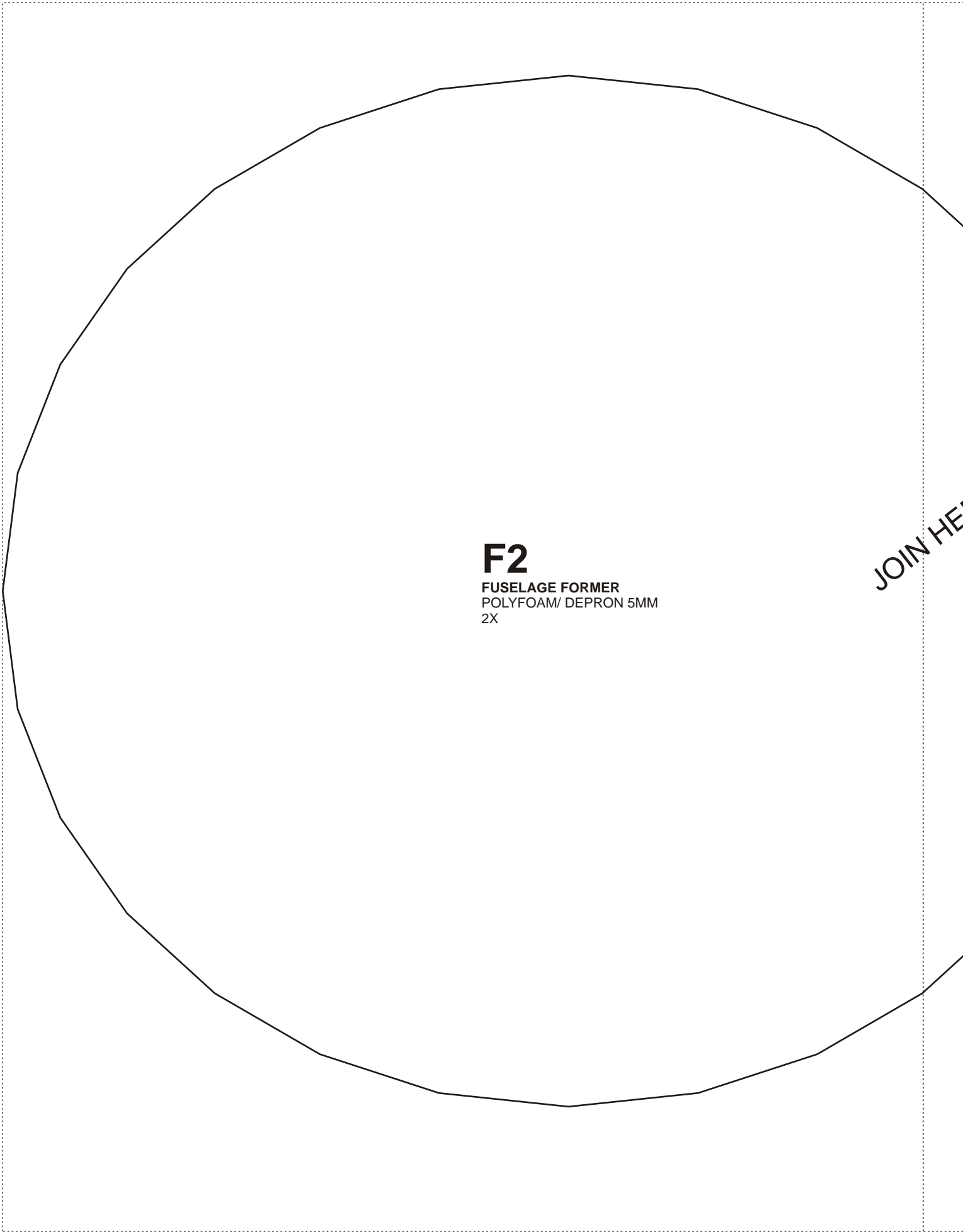

F2

FUSELAGE FORMER
POLYFOAM/ DEPRON 5MM
2X

JOIN HERE

JOIN HERE

F3

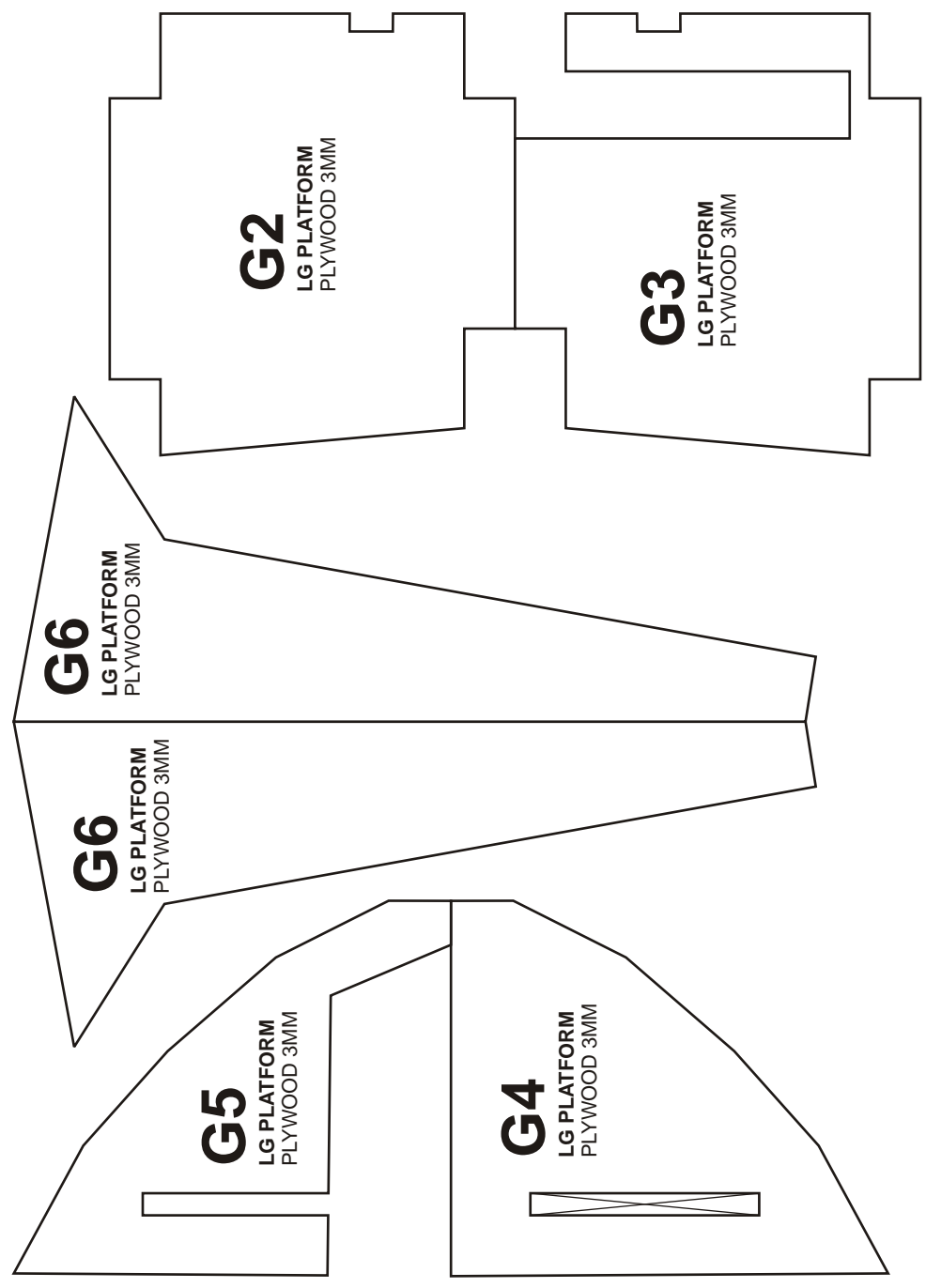



F4

FUSELAGE
POLYFOAM/ DEPRON 5MM

JOIN HERE

JOIN HERE

F4

JOIN HERE

JOIN HERE

F4

F5

FUSELAGE
POLYFOAM/ DEPRON 5MM

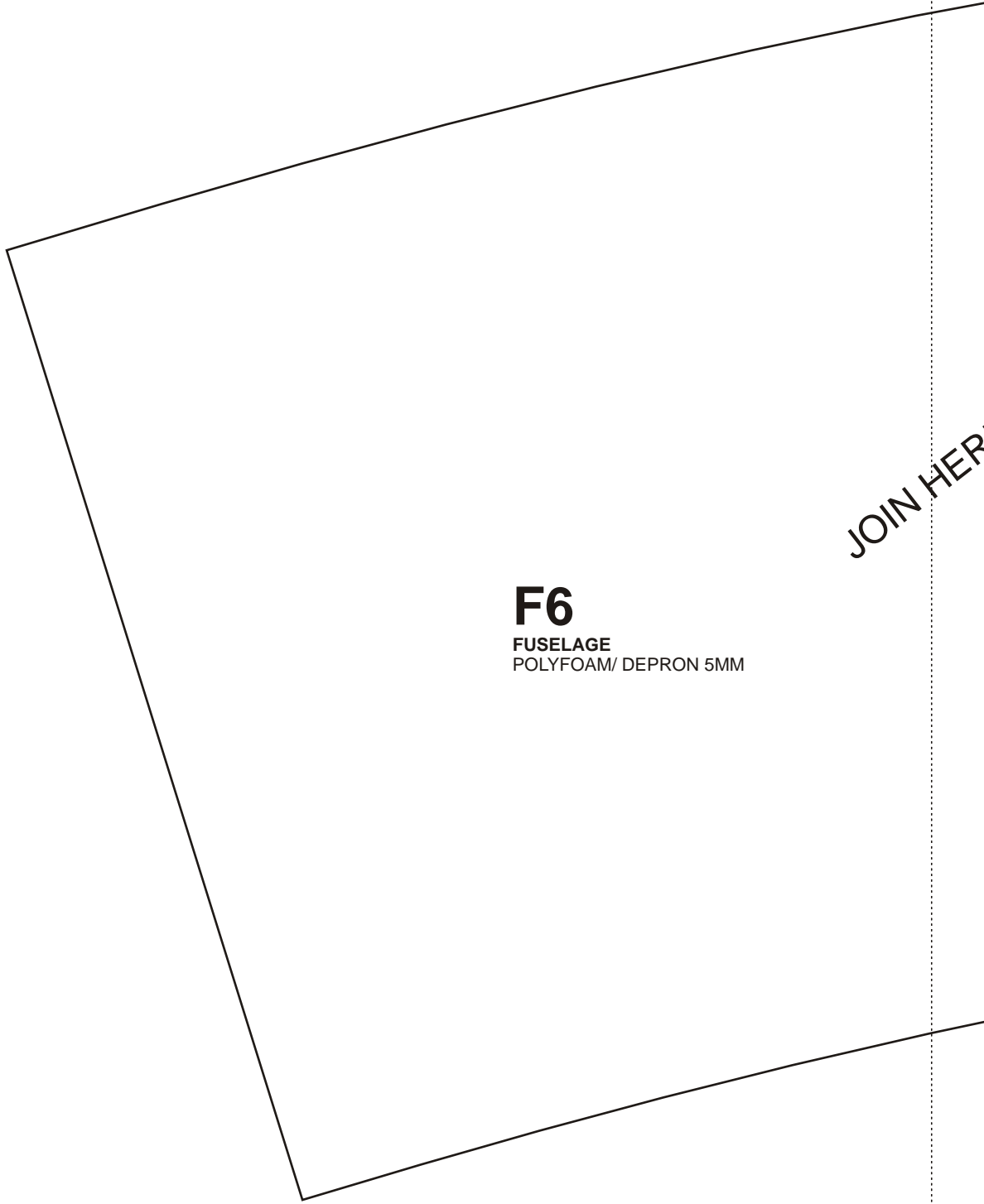

F6

FUSELAGE
POLYFOAM/ DEPRON 5MM

JOIN HERE

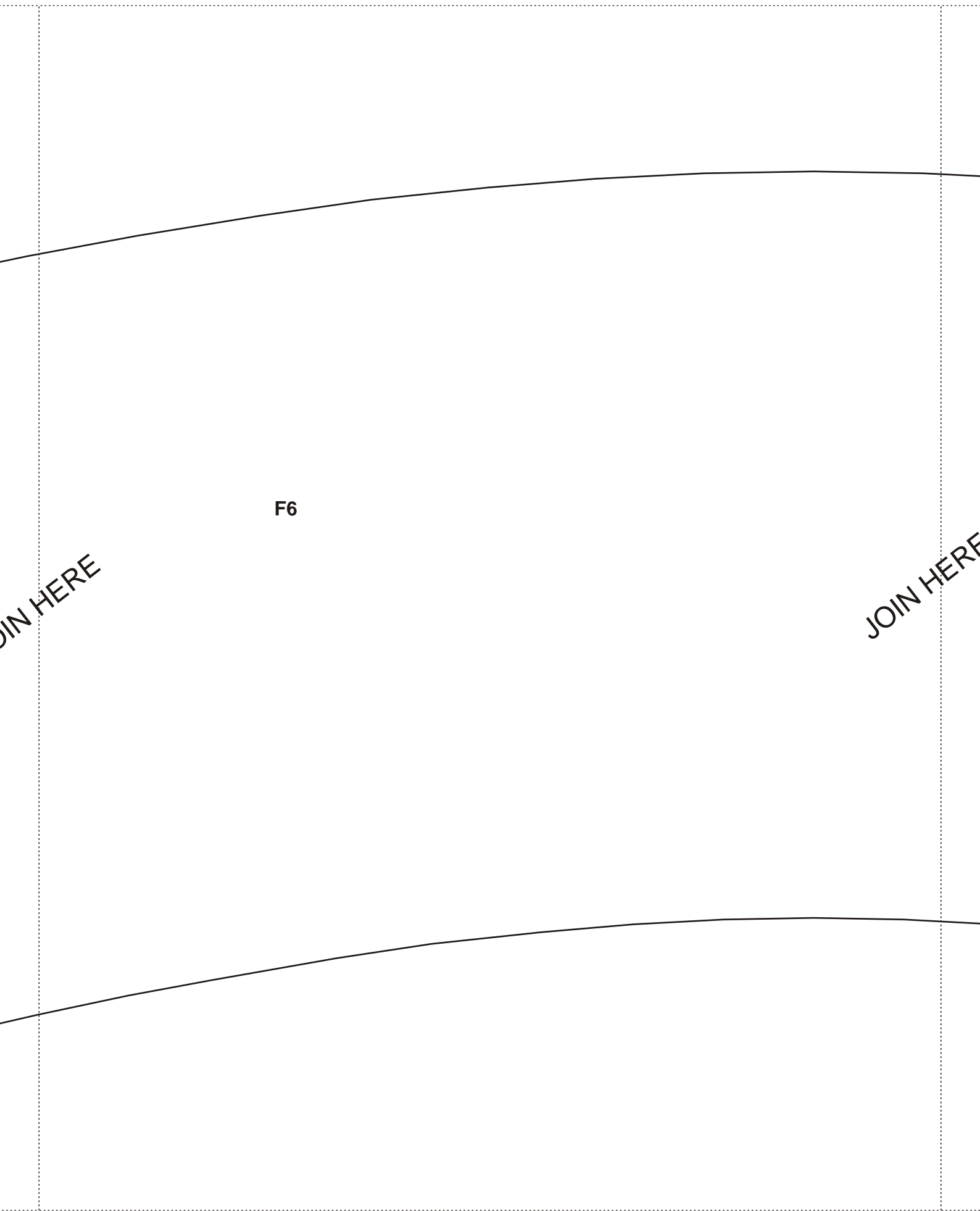

F6

JOIN HERE

JOIN HERE

JOIN HERE

F6

JOIN HERE

JOIN HERE

F6

F14

FUSELAGE
POLYFOAM/ DEPRON 5MM

G1

LG PLATFORM
PLYWOOD 3MM

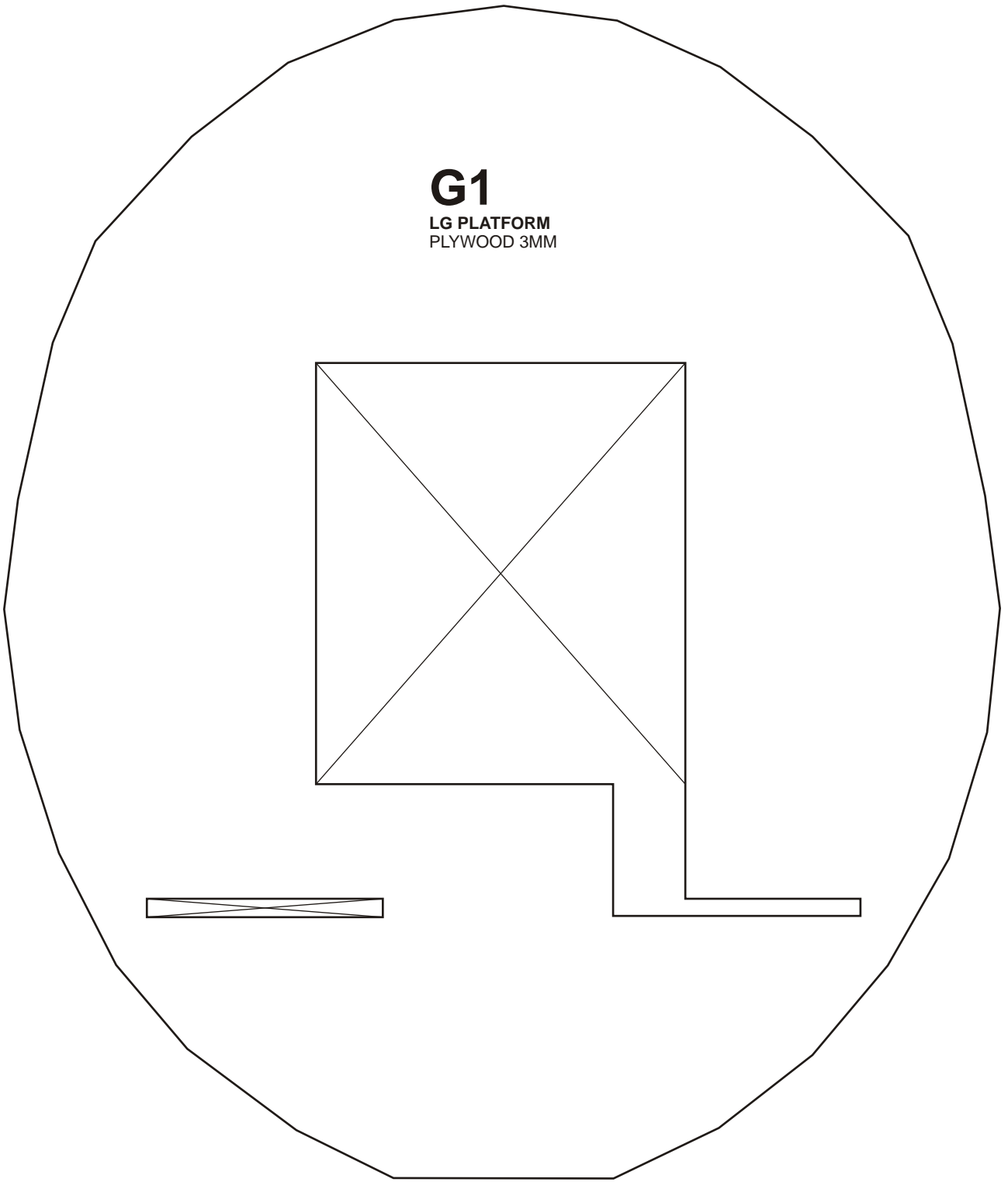



F7

NOSE SECTION
POLYFOAM/ DEPRON 5MM

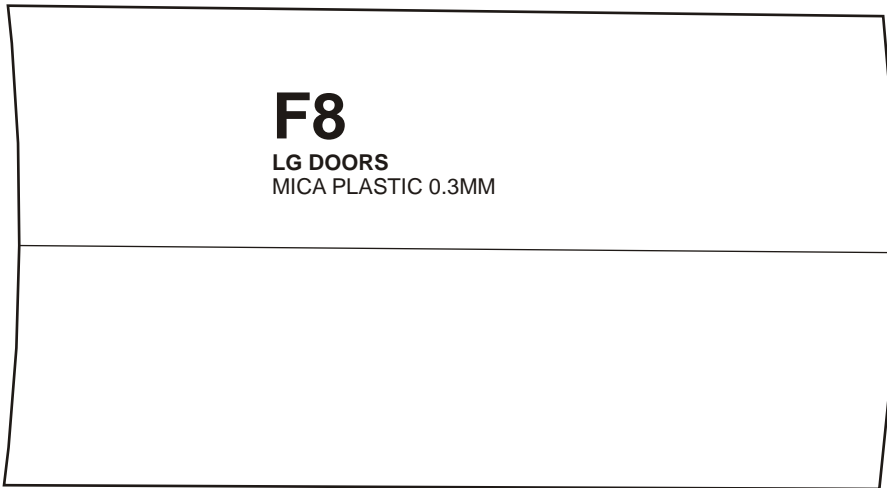

F8

LG DOORS
MICA PLASTIC 0.3MM

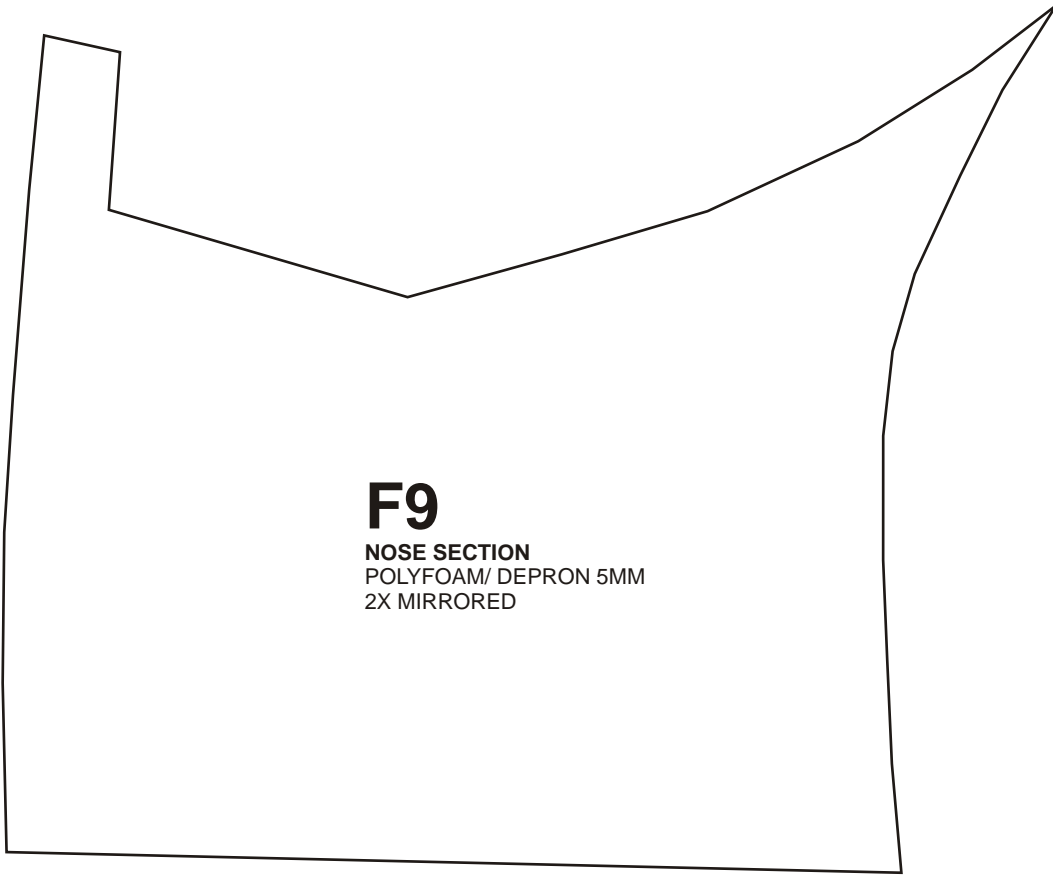

F9

NOSE SECTION
POLYFOAM/ DEPRON 5MM
2X MIRRORED

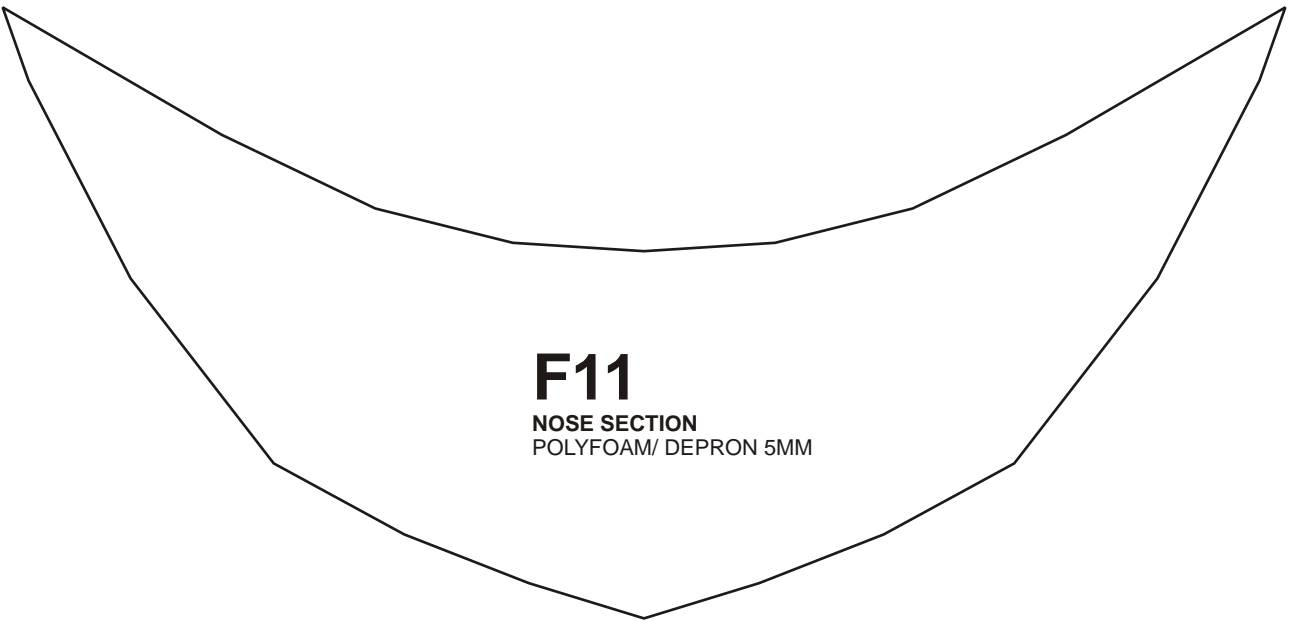

F11

NOSE SECTION
POLYFOAM/ DEPRON 5MM

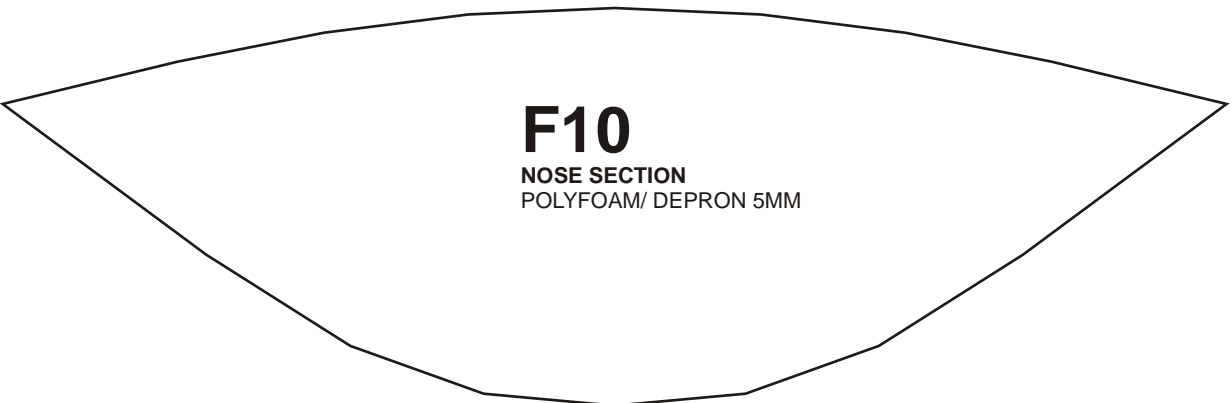

F10

NOSE SECTION
POLYFOAM/ DEPRON 5MM

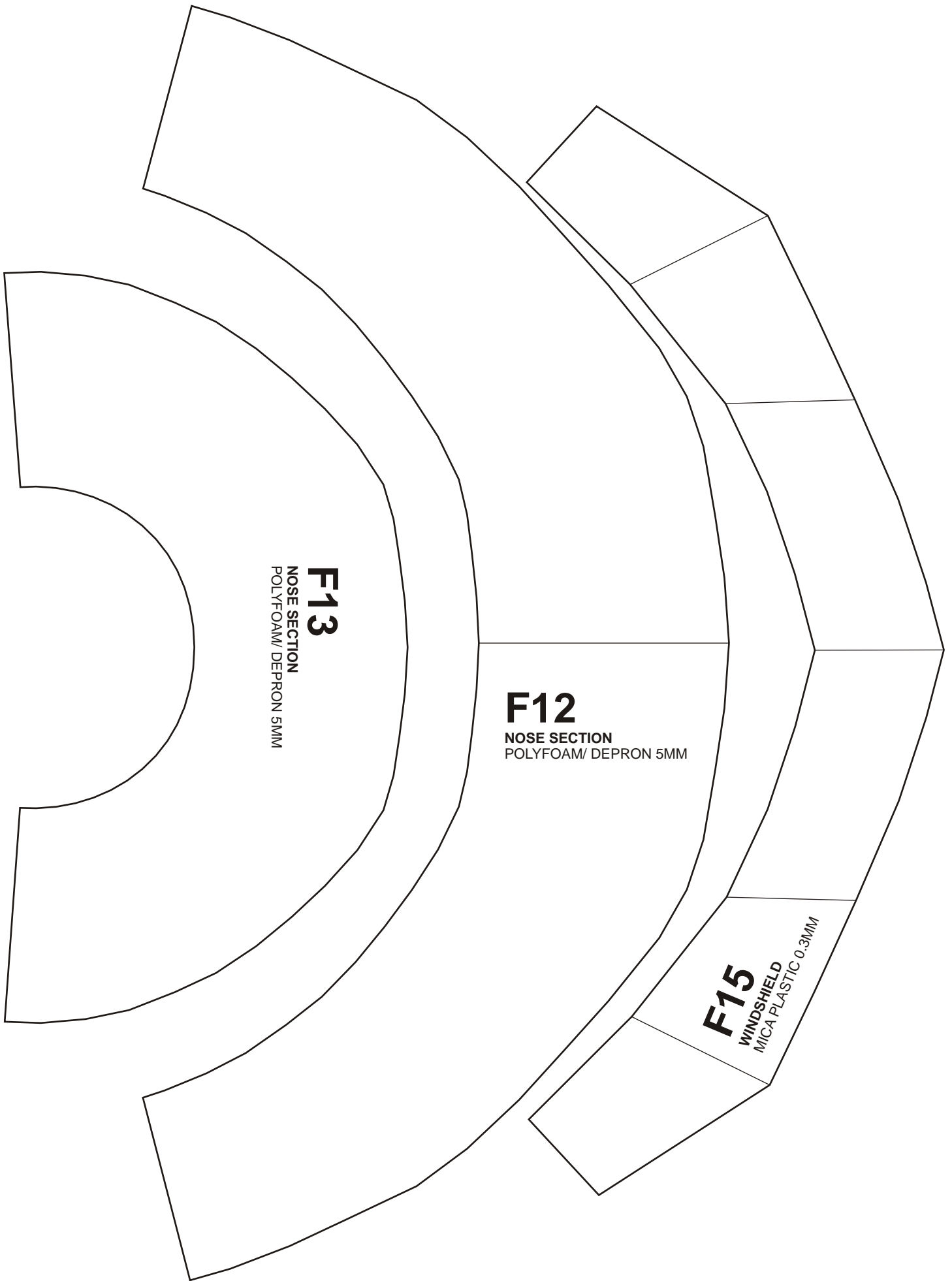

F13
NOSE SECTION
POLYFOAM/ DEPRON 5MM

F12
NOSE SECTION
POLYFOAM/ DEPRON 5MM

F15
WINDSHIELD
MICA PLASTIC 0.3MM