



Baby Corsair

Model #01-22

Wingspan : 1000 mm

Weight : 1000 gram

Motor : 750kv Bell motor / DXW 3536 1200kv

Prop : 12 inch

ESC : 40A

Battery : 3S 2200 mAh

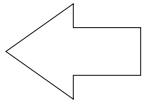

FRONT



ROOT

SPAR

W1

BOTTOM WING
POLYFOAM/
DEPRON 3MM
2X MIRRORED

JOIN HERE

W2

FORMER
POLYFOAM/
DEPRON 5MM
6X

JOIN HERE

JOIN HERE

W1

JOIN HERE

W2

W4

SPAR
POLYFOAM/
DEPRON 5MM
2X MIRRORED

ROOT

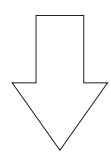

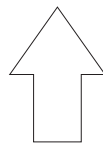

ROOT

W3

UPPER WING
POLYFOAM/
DEPRON 3MM
2X MIRRORED

JOIN HERE

JOIN HERE

W3

W5

BOTTOM WING
POLYFOAM/
DEPRON 3MM
2X MIRRORED

JOIN HERE

SPAR

JOIN HERE

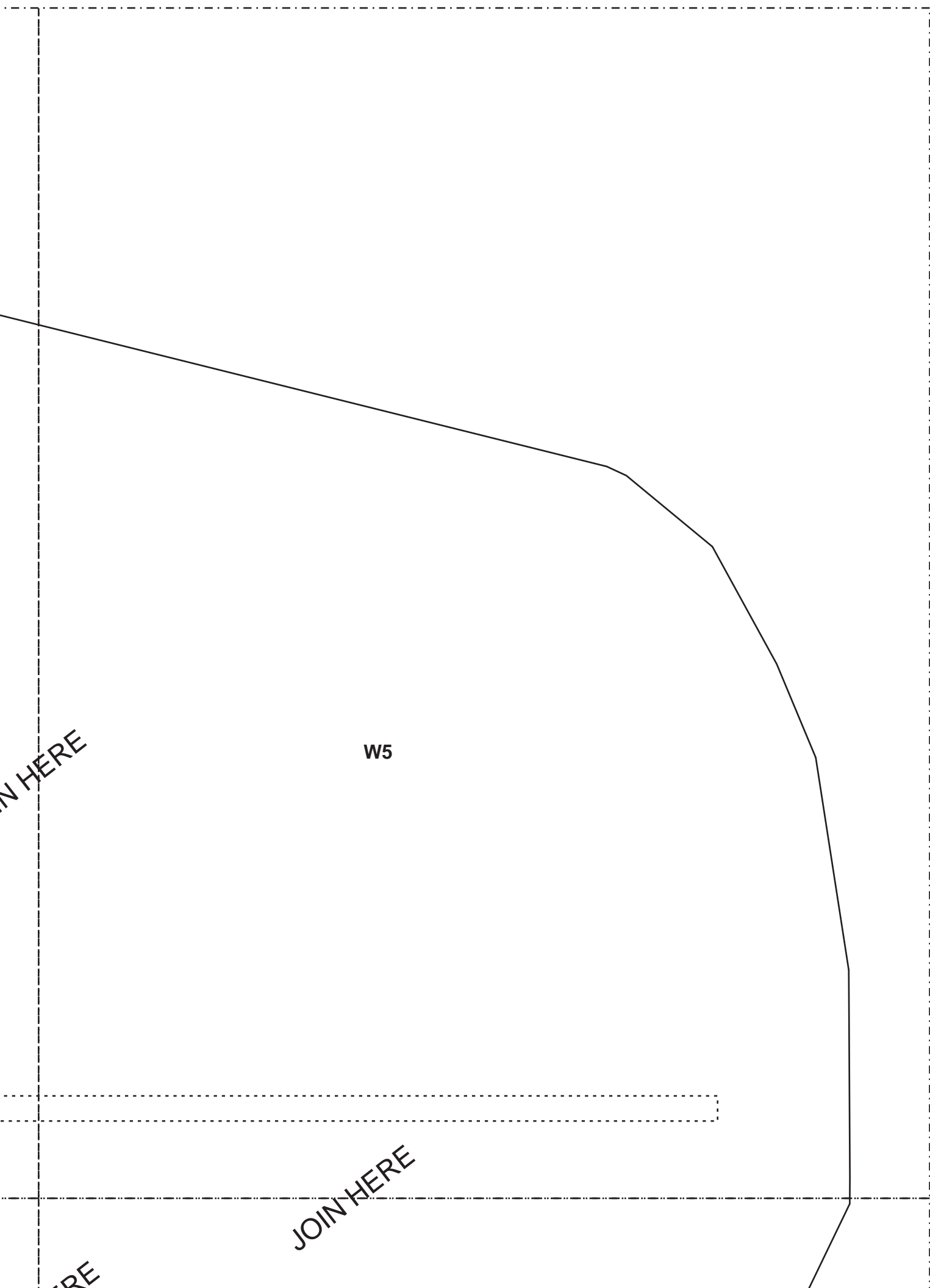

SPAR

JOIN HERE

JOIN HER

W5

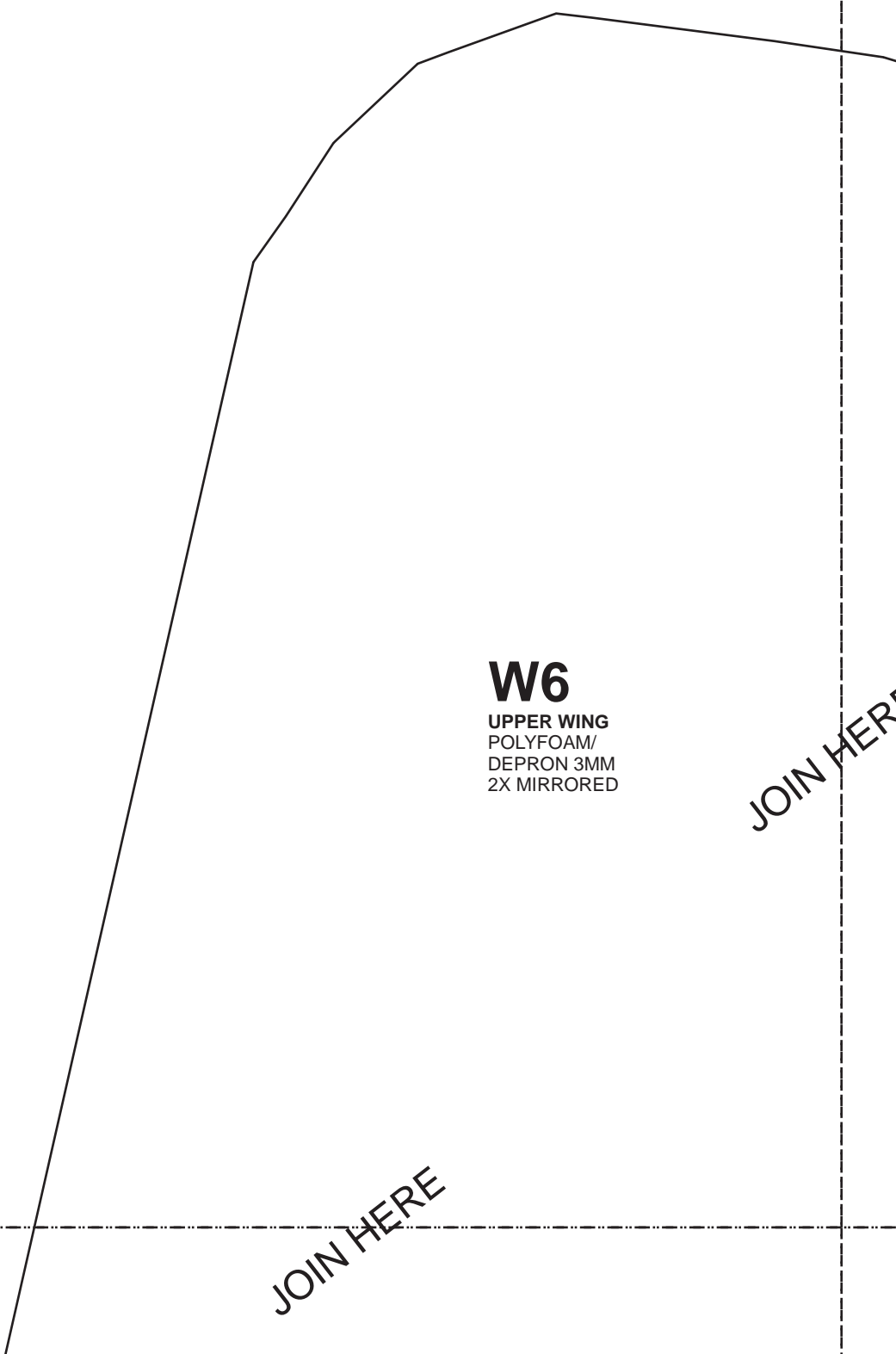

W6
UPPER WING
POLYFOAM/
DEPRON 3MM
2X MIRRORED

JOIN HER

JOIN HERE

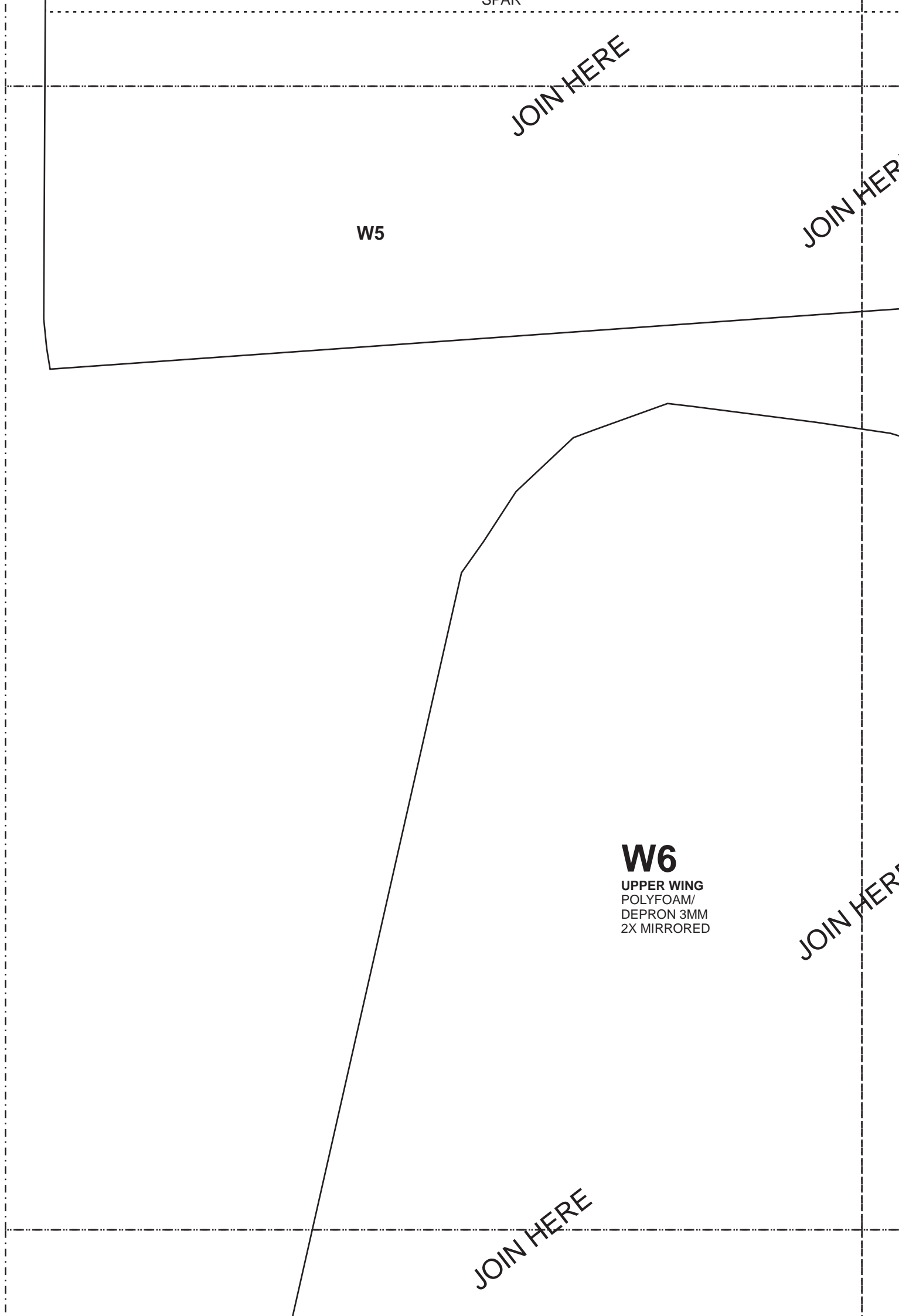

JOIN HERE

JOIN HERE

W5

JOIN HERE

W6

JOIN HERE

W6

SPAR
POLYFOAM/
DEPRON 5MM
2X MIRRORED

JOIN HERE

JOIN HERE

JOIN HERE

W6

JOIN HERE

JOIN HERE

JOIN HERE

W6

W7

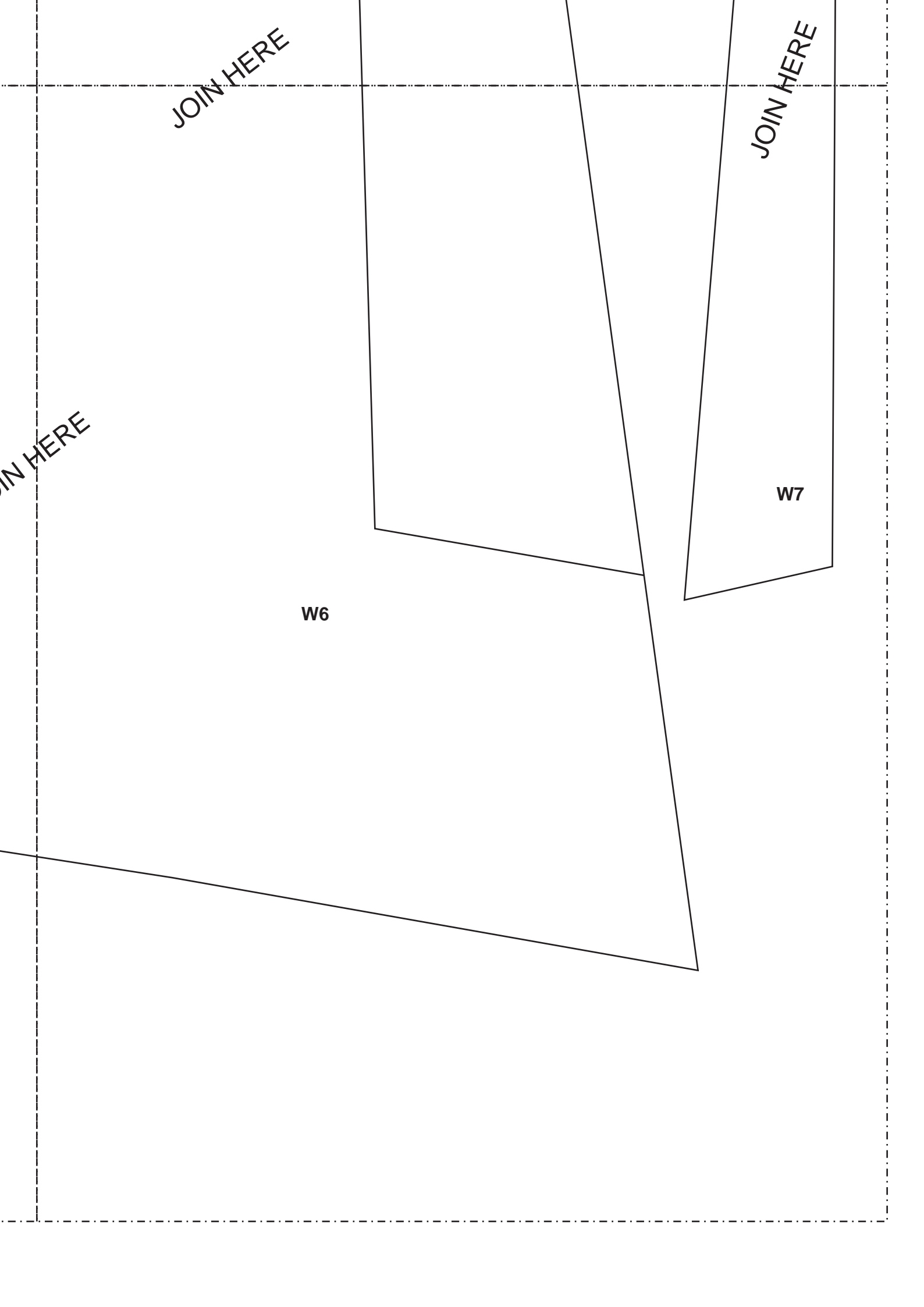

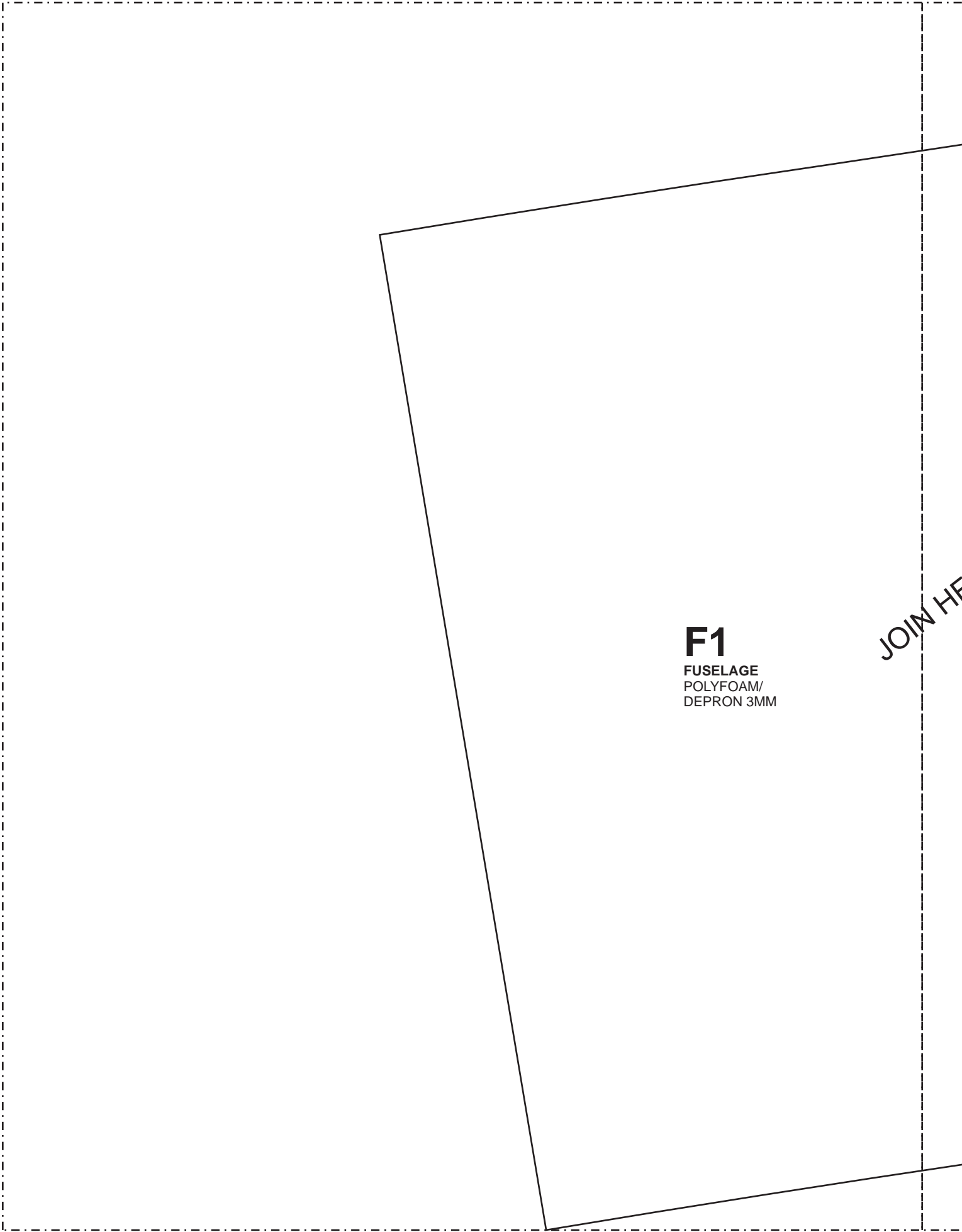

F1

FUSELAGE
POLYFOAM/
DEPRON 3MM

JOIN HF

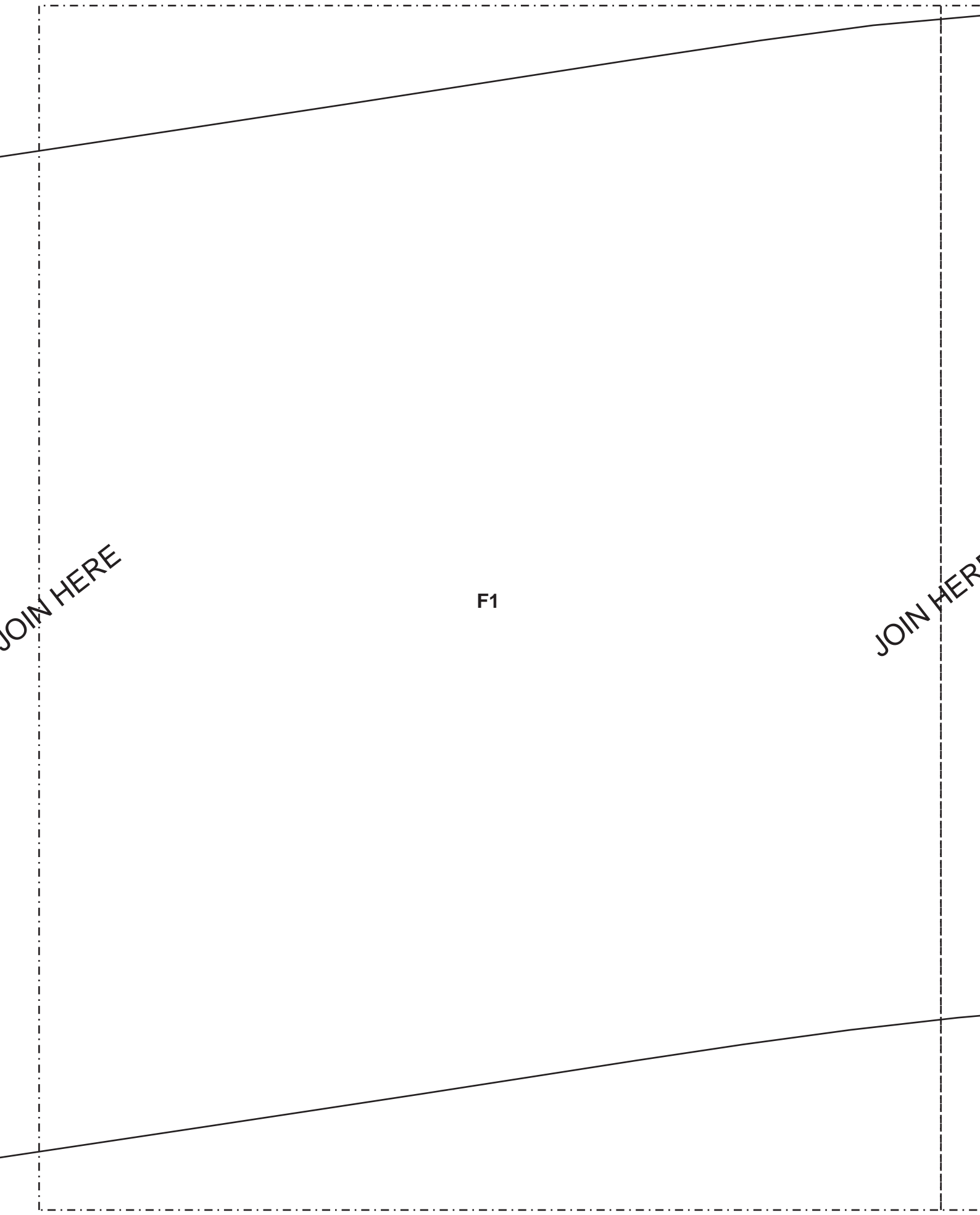

JOIN HERE

F1

JOIN HERE

JOIN HERE

F1

JOIN HERE

JOIN HERE

F1

JOIN HERE

JOIN HERE

F1

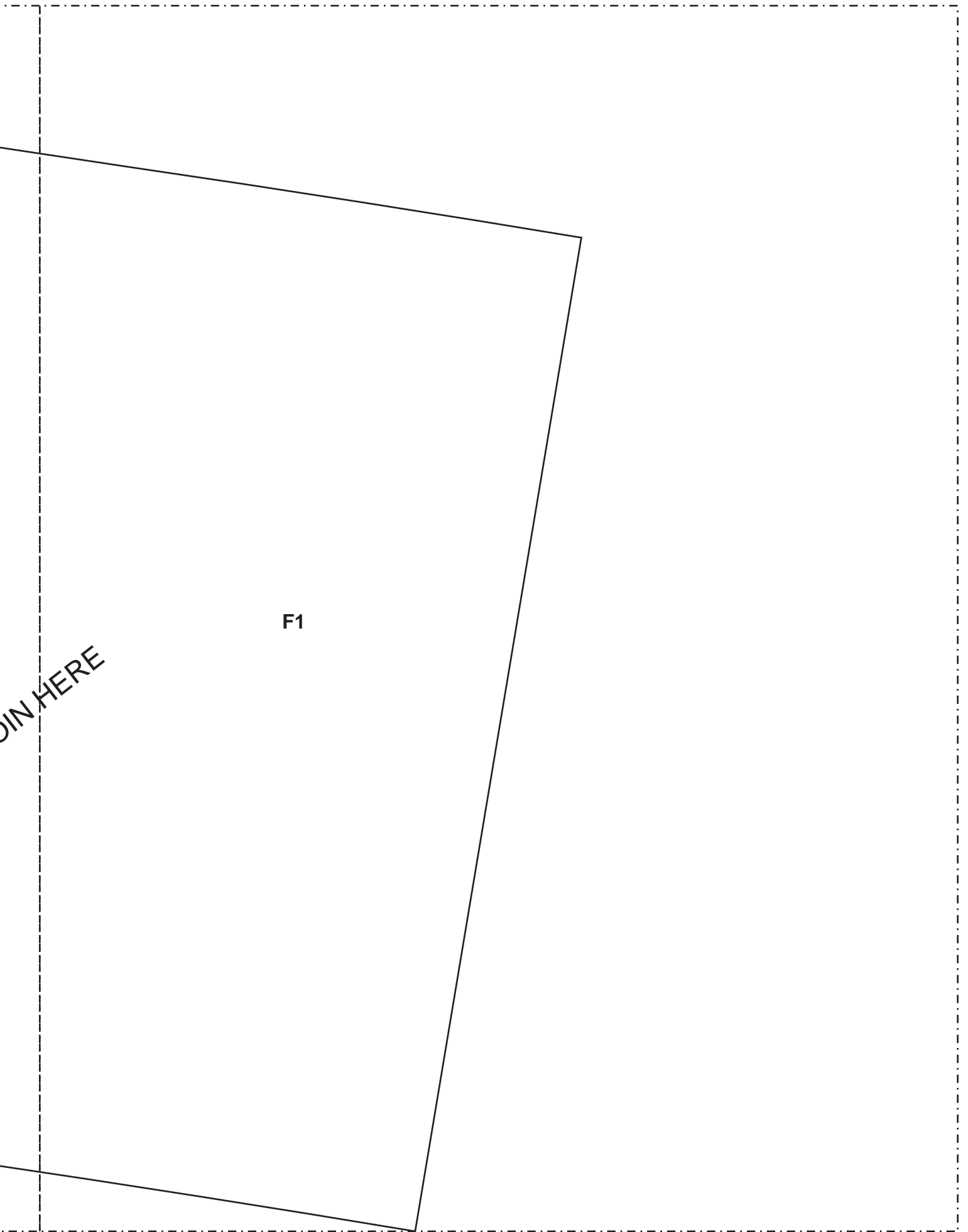

JOIN HERE

F3

FUSELAGE
POLYFOAM/
DEPRON 3MM

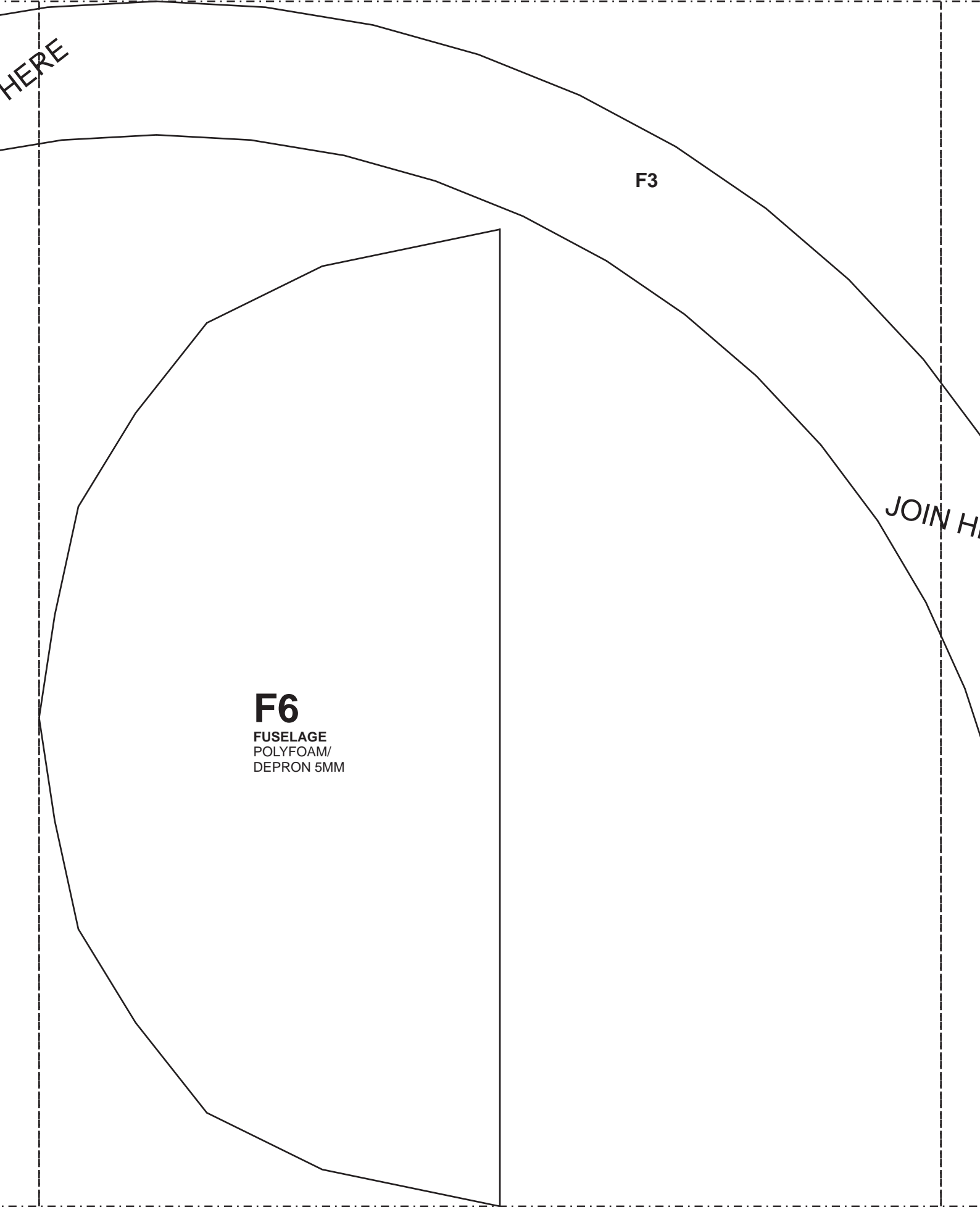

HERE

F3

F6
FUSELAGE
POLYFOAM/
DEPRON 5MM

JOIN H...

JOIN HERE

JOIN HERE

F2

FUSELAGE
POLYFOAM/
DEPRON 5MM

HERE

F2

F5
FUSELAGE
POLYFOAM/
DEPRON 5MM

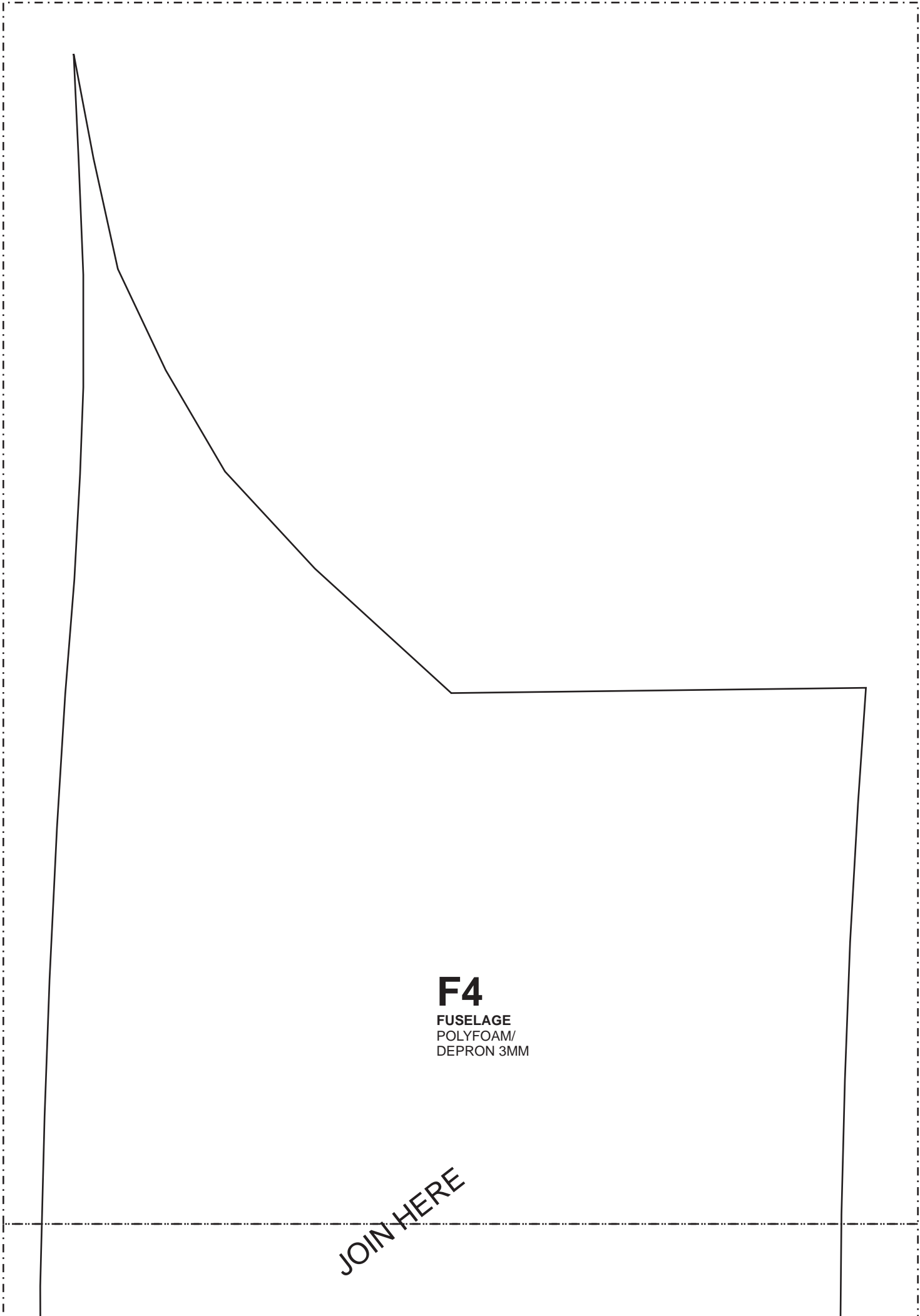

F4

FUSELAGE
POLYFOAM/
DEPRON 3MM

JOIN HERE

JOIN HERE

F4



F4

FUSELAGE
POLYFOAM/
DEPRON 3MM

JOIN HERE

JOIN HERE

F4

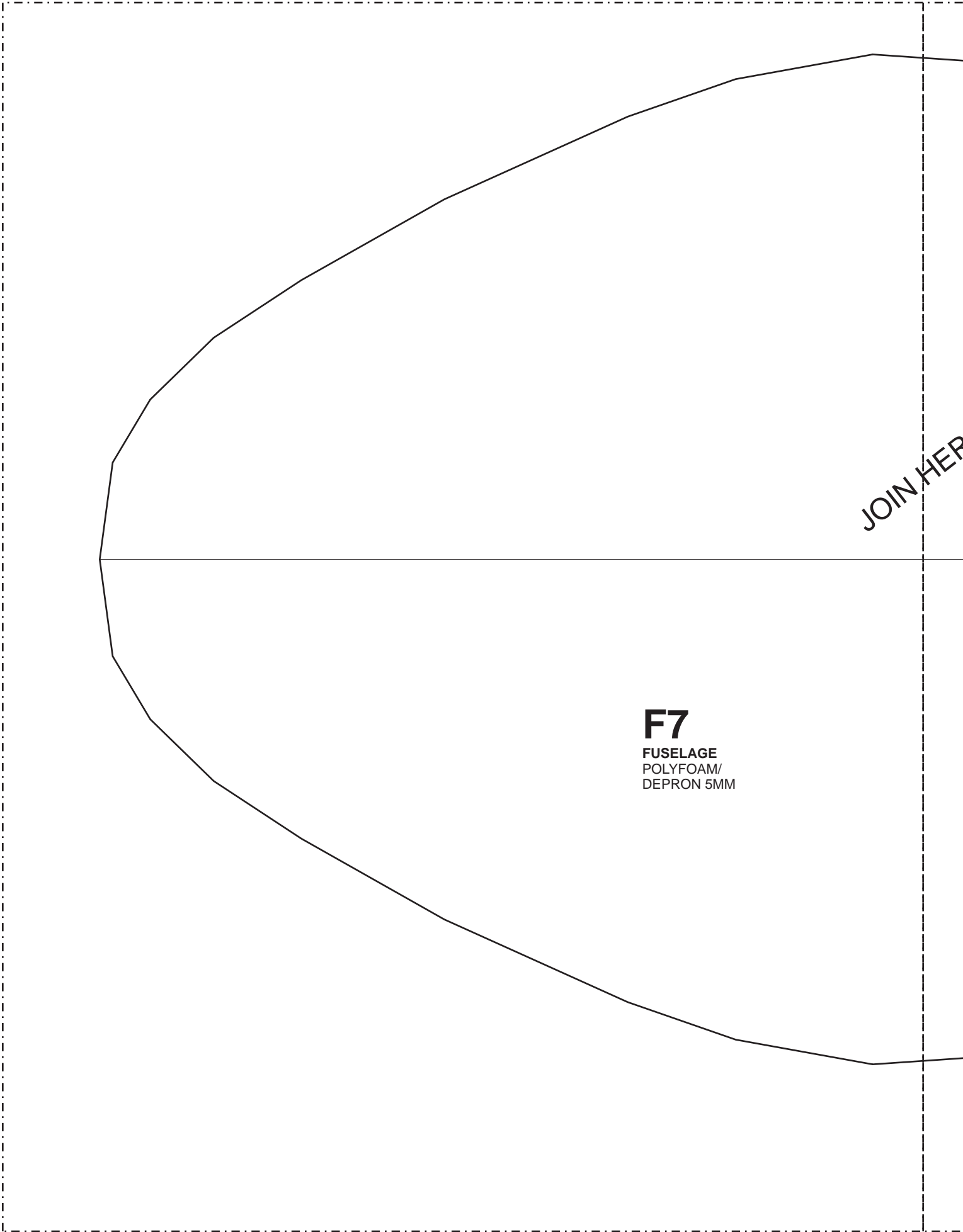

JOIN HERE

F7
FUSELAGE
POLYFOAM/
DEPRON 5MM

JOIN HERE

F7

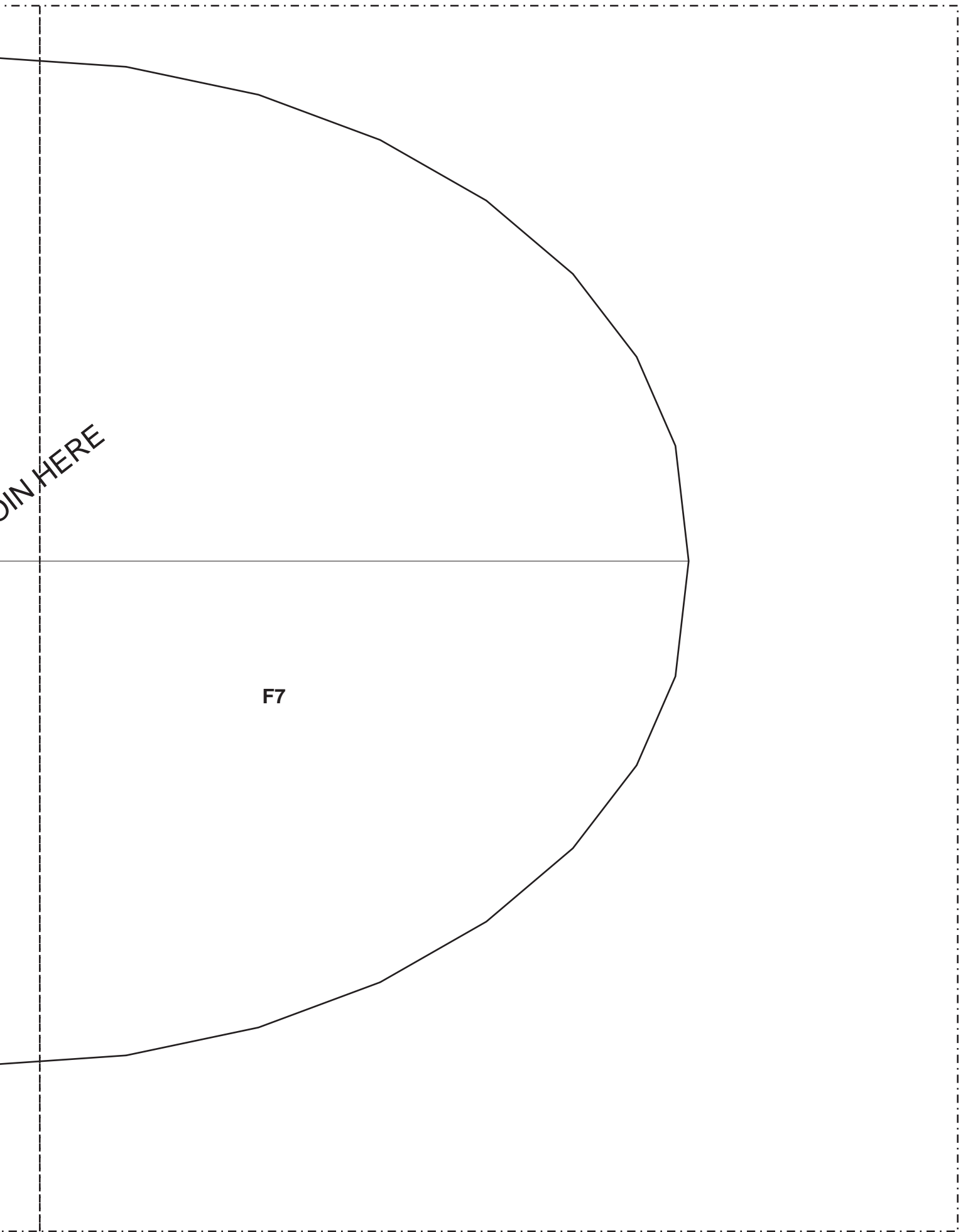

F8

FUSELAGE
POLYFOAM/
DEPRON 3MM

JOIN HERE

JOIN HERE

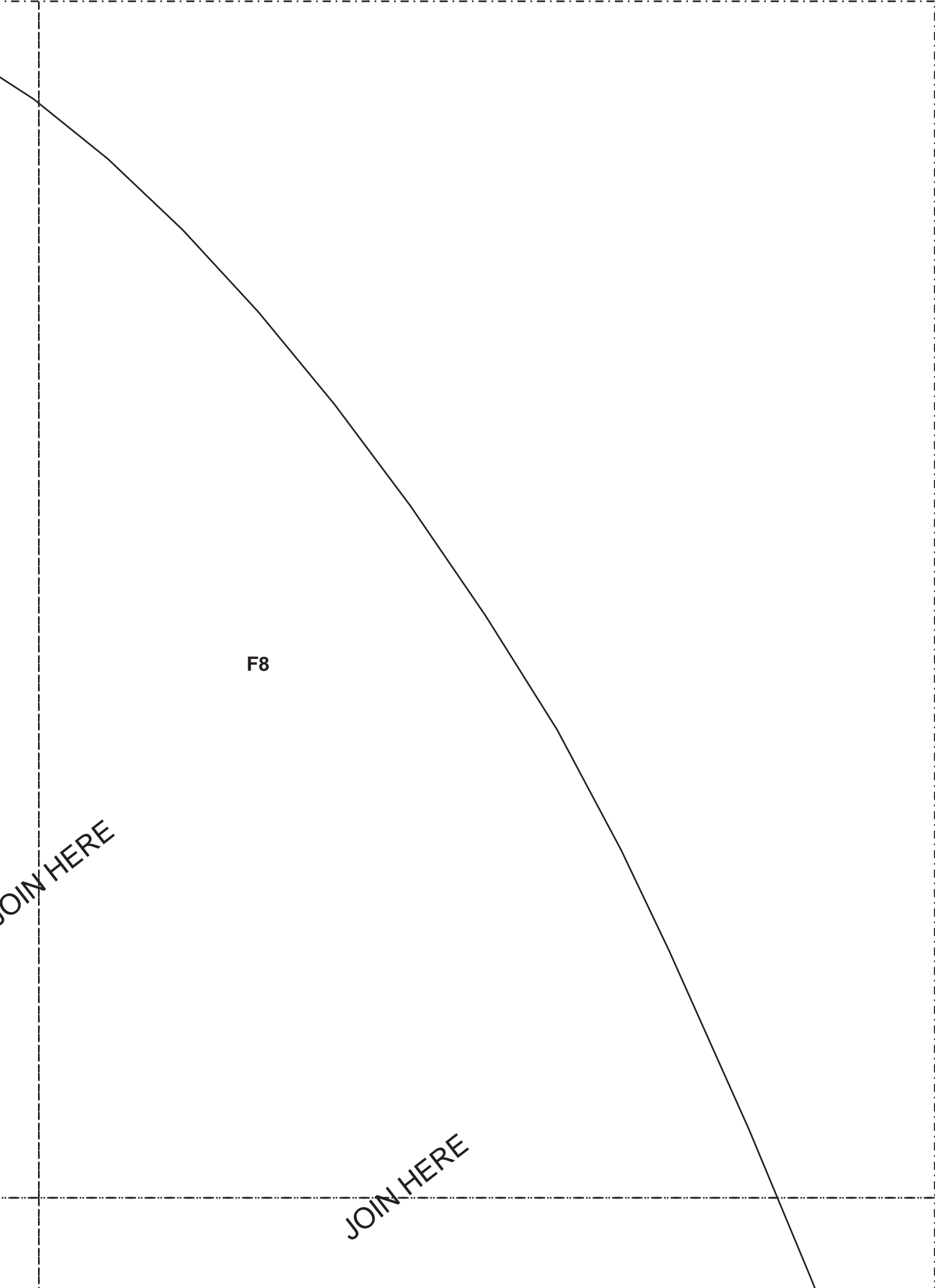

F8

JOIN HERE

JOIN HERE

JOIN HERE

F8

JOIN HERE

JOIN HERE

JOIN HERE

JOIN HERE

F8

JOIN HERE

JOIN HERE

JOIN HERE

F8

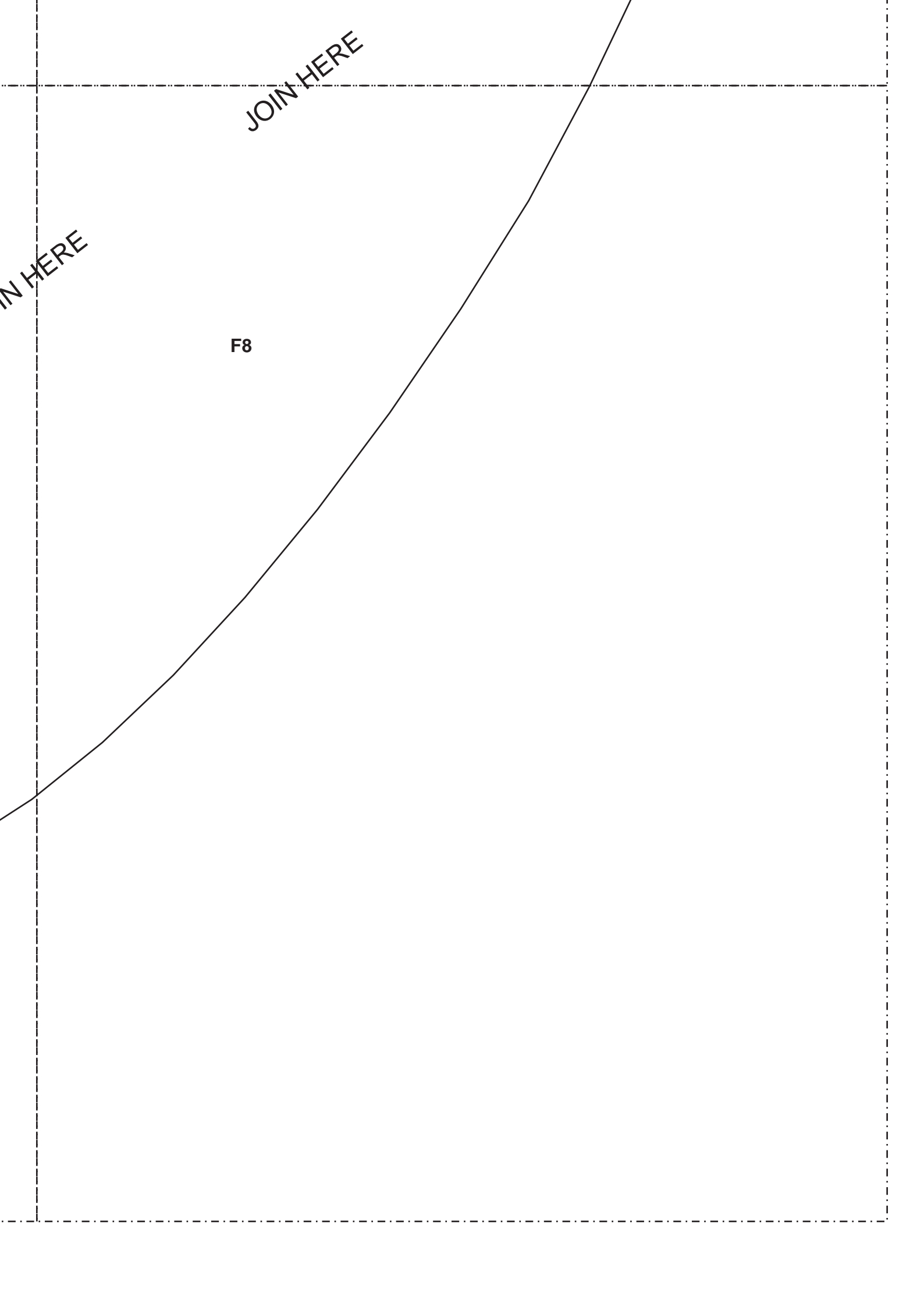

JOIN HERE

JOIN HERE

F8

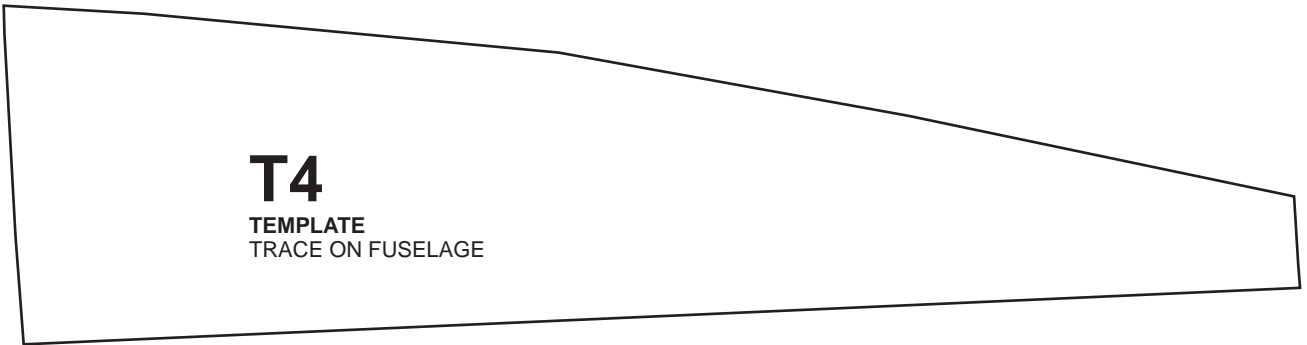
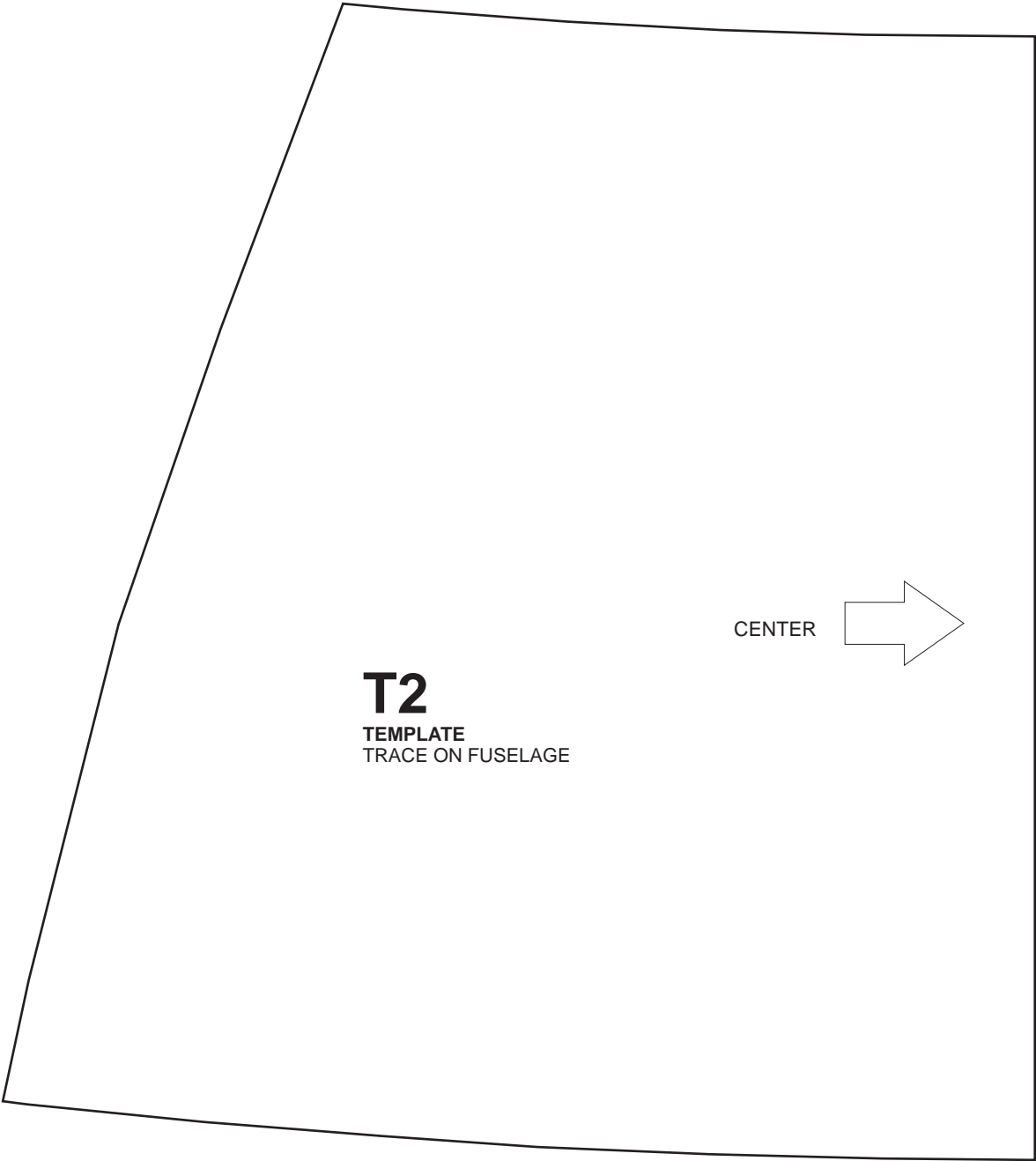

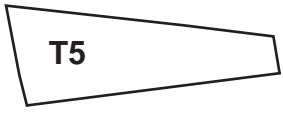
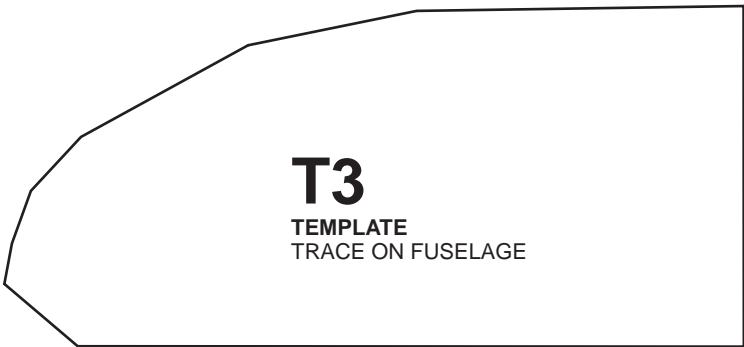
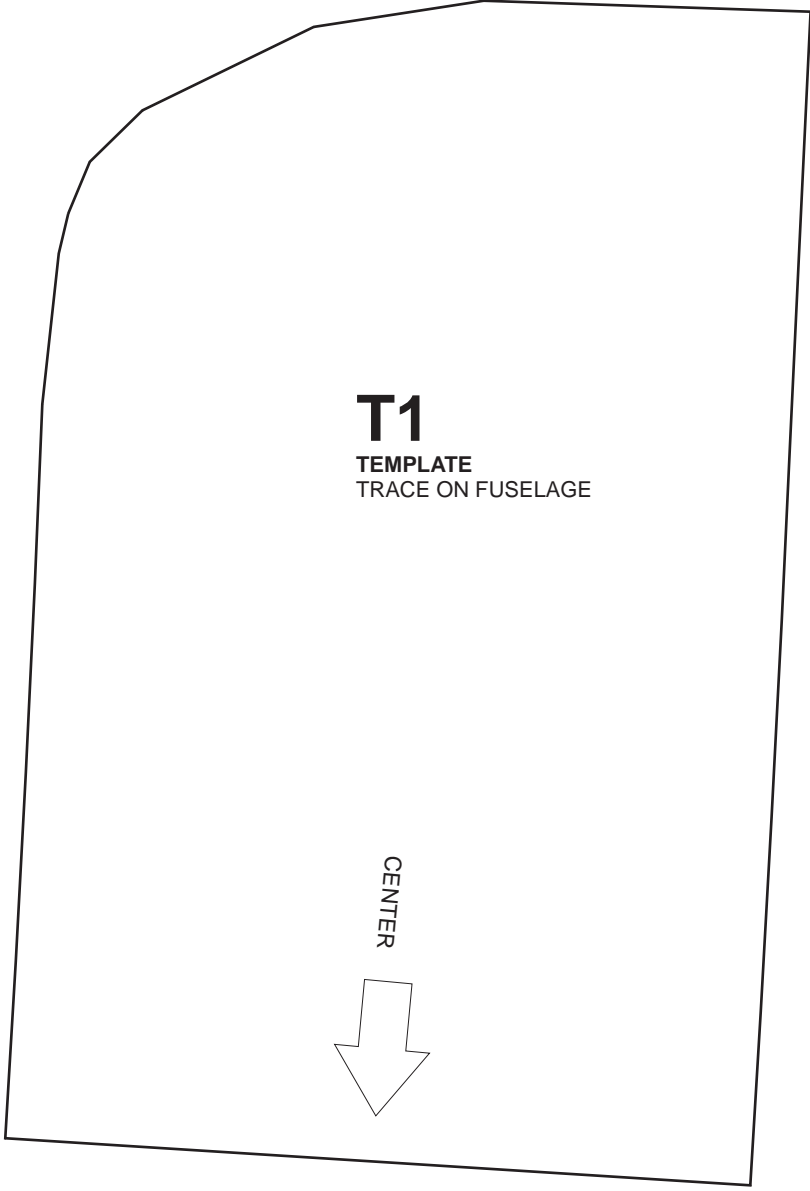

S1
VERTICAL STAB
POLYFOAM/
DEPRON 5MM

JOIN HERE

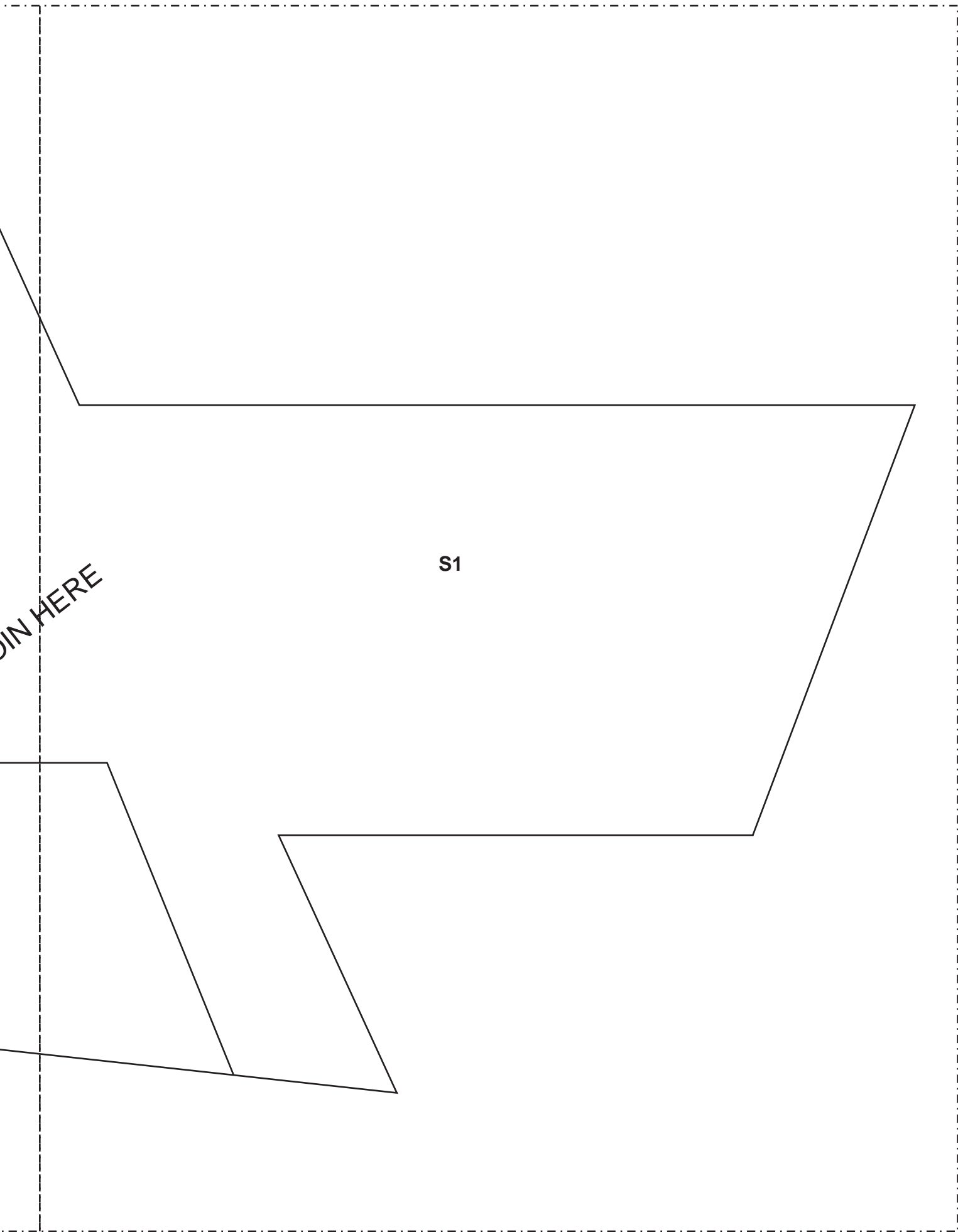

S1

JOIN HERE

HORIZONTAL STAB LOWER
POSITION



T6

TEMPLATE
TRACE ON FUSELAGE

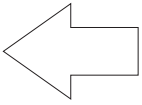

FRONT

LOWER SEAM



S2

HORIZONTAL STAB
POLYFOAM/
DEPRON 5MM

JOIN HERE

JOIN HERE

S2

JOIN HERE

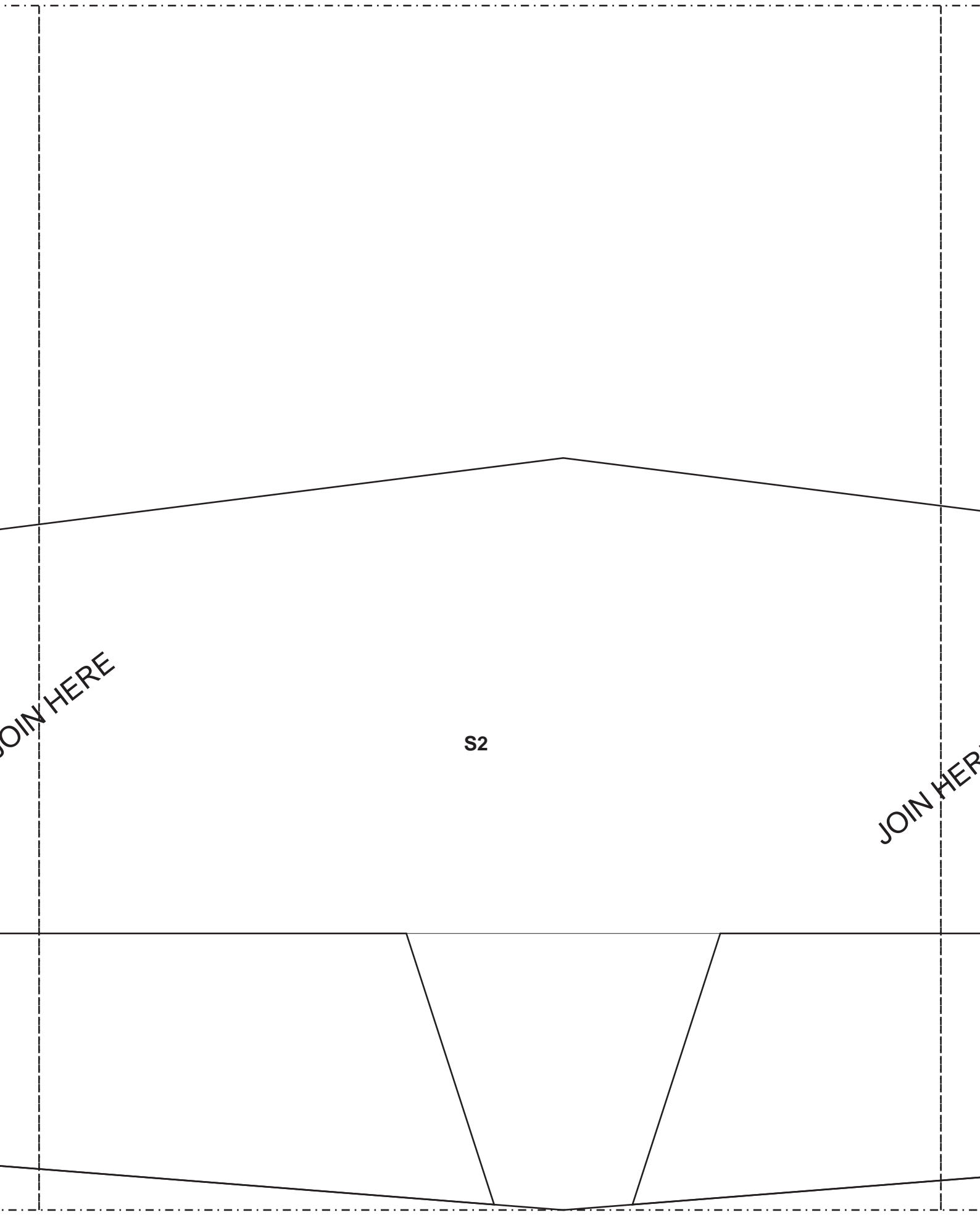

JOIN HERE

S2

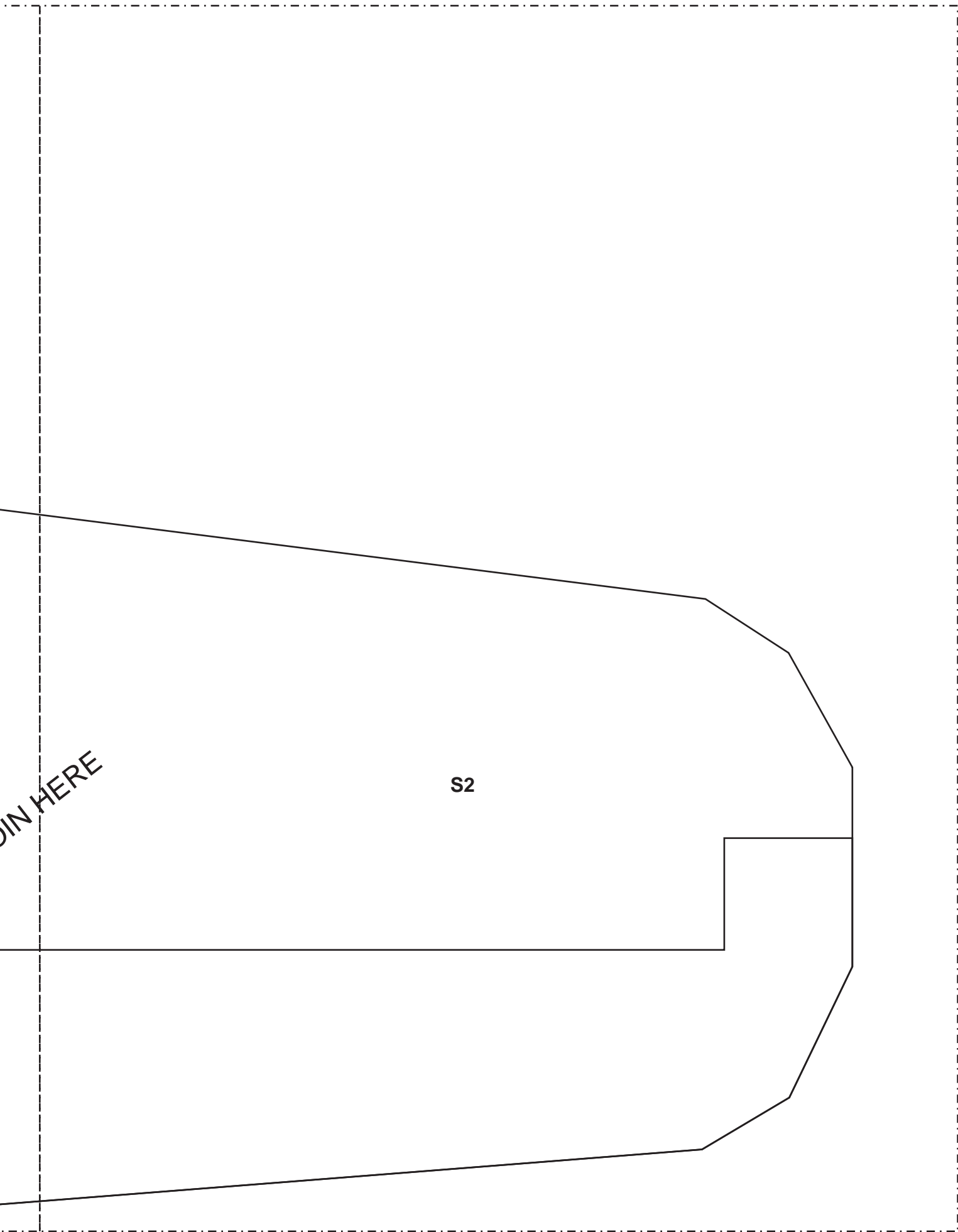

C2
CANOPY
MICA PLASTIC
0.3MM

mika

C1

JOIN HERE

JOIN HERE

JOIN HERE

JOIN HERE

C2

C1
CANOPY
MICA PLASTIC
0.3MM

mika

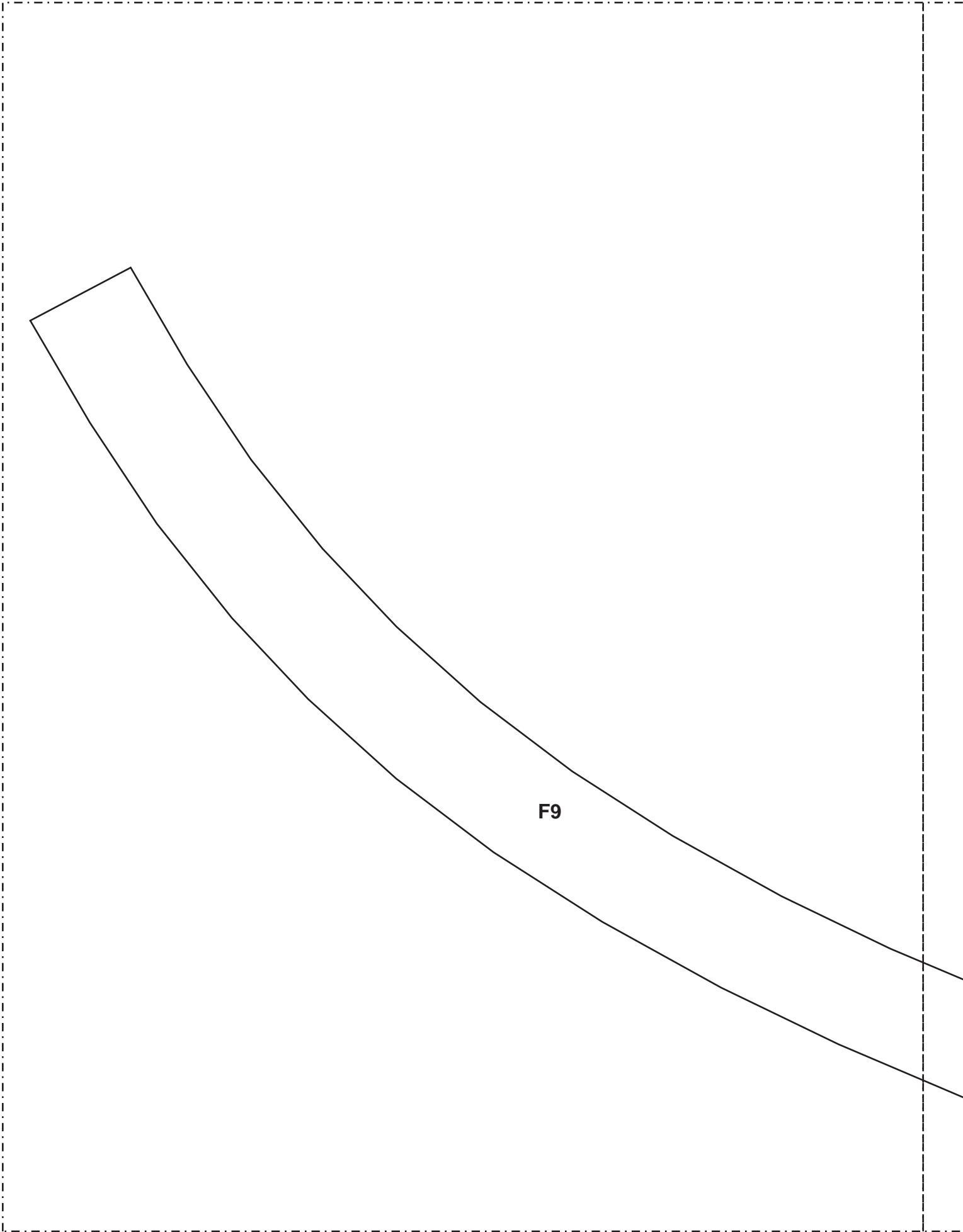

F11

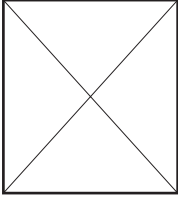

SERVO PLATFORM
POLYFOAM/
DEPRON 5MM
3X

F10

BATTERY PLATFORM
POLYFOAM/
DEPRON 5MM
2X

G1

LG BASE
PLYWOOD 3MM
2X

G2

LG BASE
PLYWOOD
3MM

F9

ENGINE COWL DETAIL
POLYFOAM/
DEPRON 3MM

MOTOR THRUST ANGLE

TOP VIEW

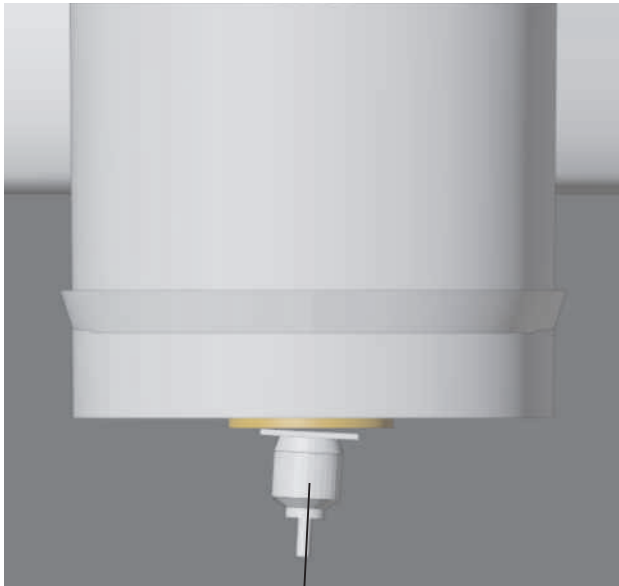

SIDE VIEW

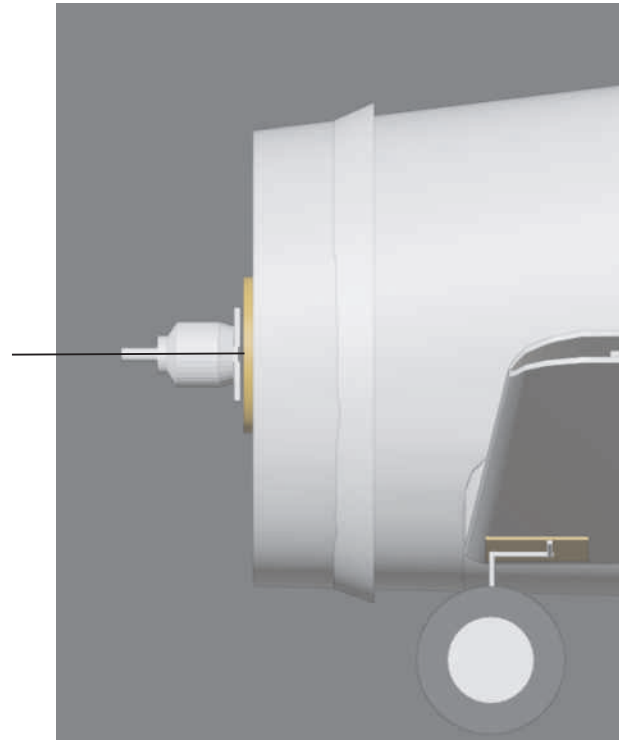

F9

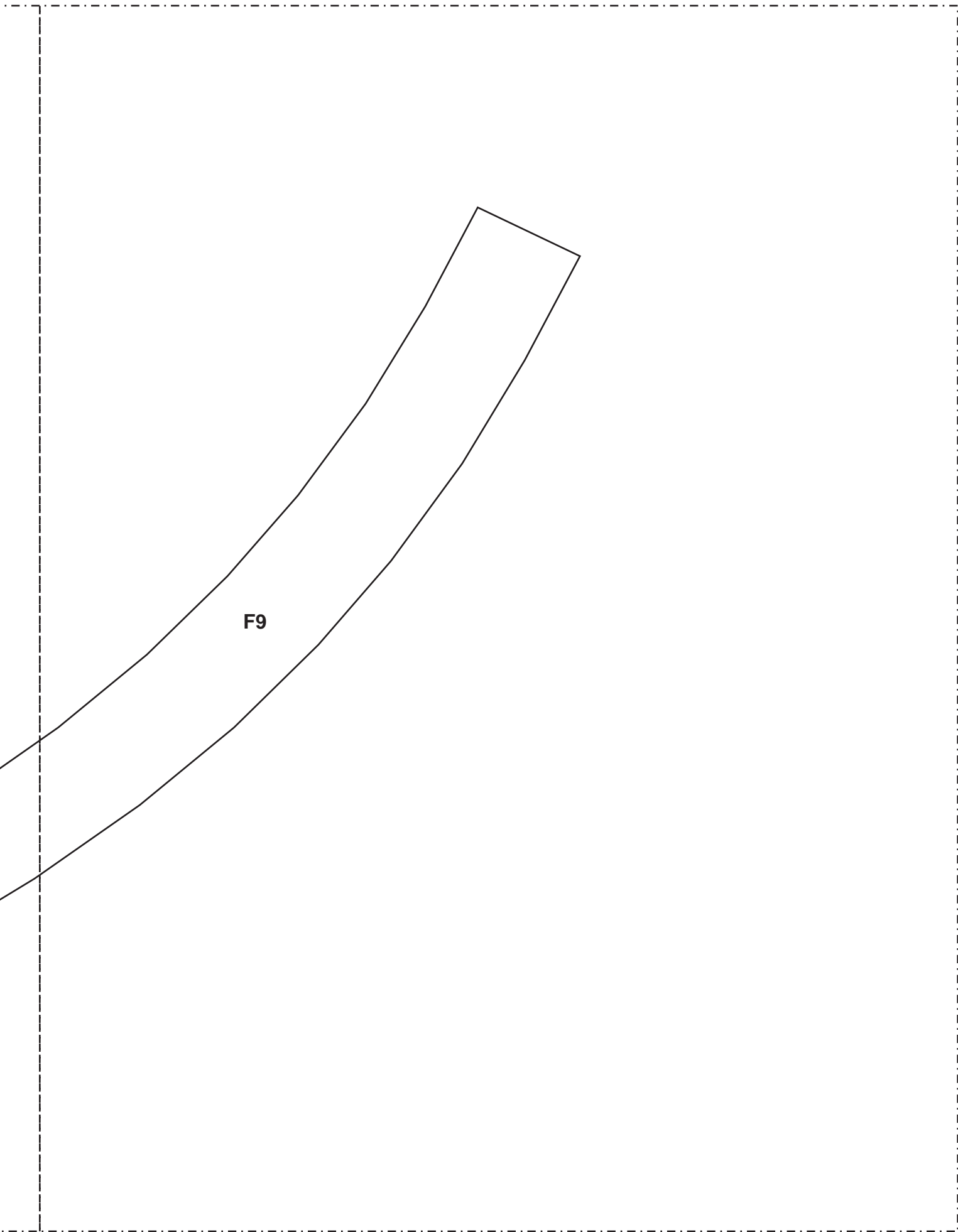

F9

MAIN LANDING GEAR

