



Model : 39/2023



# A-10 Thunderbolt II

## 1700mm

### Specs :

1. Wingspan 1700 mm / 67 inches
2. Flying weight : 3600 grams/ 127 oz
3. Wing loading : 80.4 gram/dm<sup>2</sup> - 26.4 oz/sq.ft.
4. Wing cube loading : 12
5. Wing Area : 44.80 dm<sup>2</sup> / 694 sq.in.
6. CG : 9 cm / 3.5 inch from leading edge

### Electronics (EDF)

- 2x FMS EDF 12 blade 1900kv
- 2x 80A ESC Hobbywing Skywalker
- 4x Battery Lipo 3S 2200mah (6S setup)
- 7 x 9 gram servos (metal micro servo)

### Pusher

- 2X DXW 3536 1200kv
- 2x 50A ESC
- 3S Lipo 2200 mAh X2
- 9x6x3 Prop

### Smoking Effect :

- EDF 50mm
- 2S Battery 1000mah

### Materials :

1. 5mm Foamboard/ Depron/ Polyfoam
2. 2mm Plywood
3. hot glue, UHU glue, CA glue
4. laminating film
5. Mica plastic 0.3mm
6. Paper card

### Build Instructions :

1. [paper-replika.com](http://paper-replika.com)
2. youtube channel : Julius Perdana

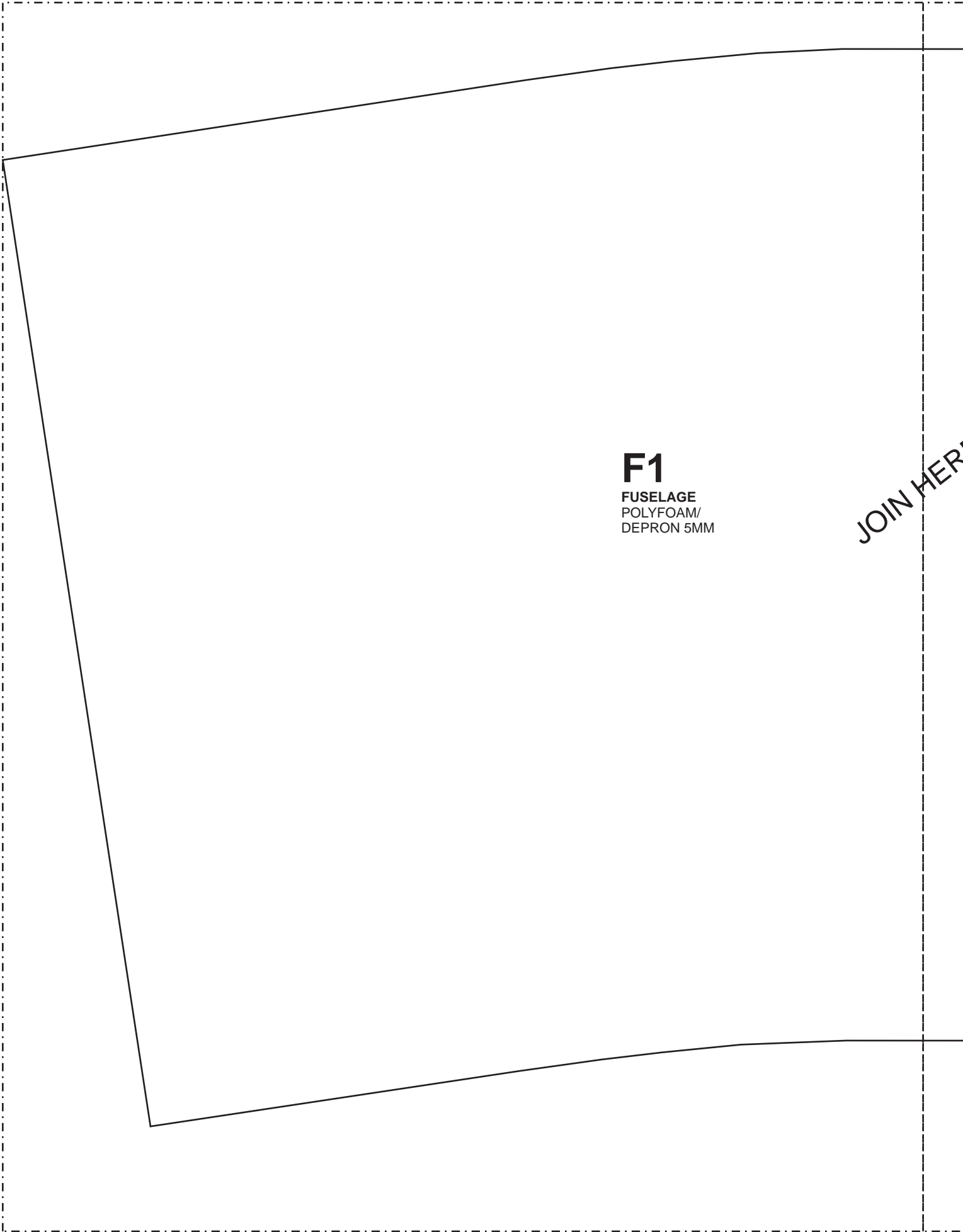

**F1**

FUSELAGE  
POLYFOAM/  
DEPRON 5MM

JOIN HERE

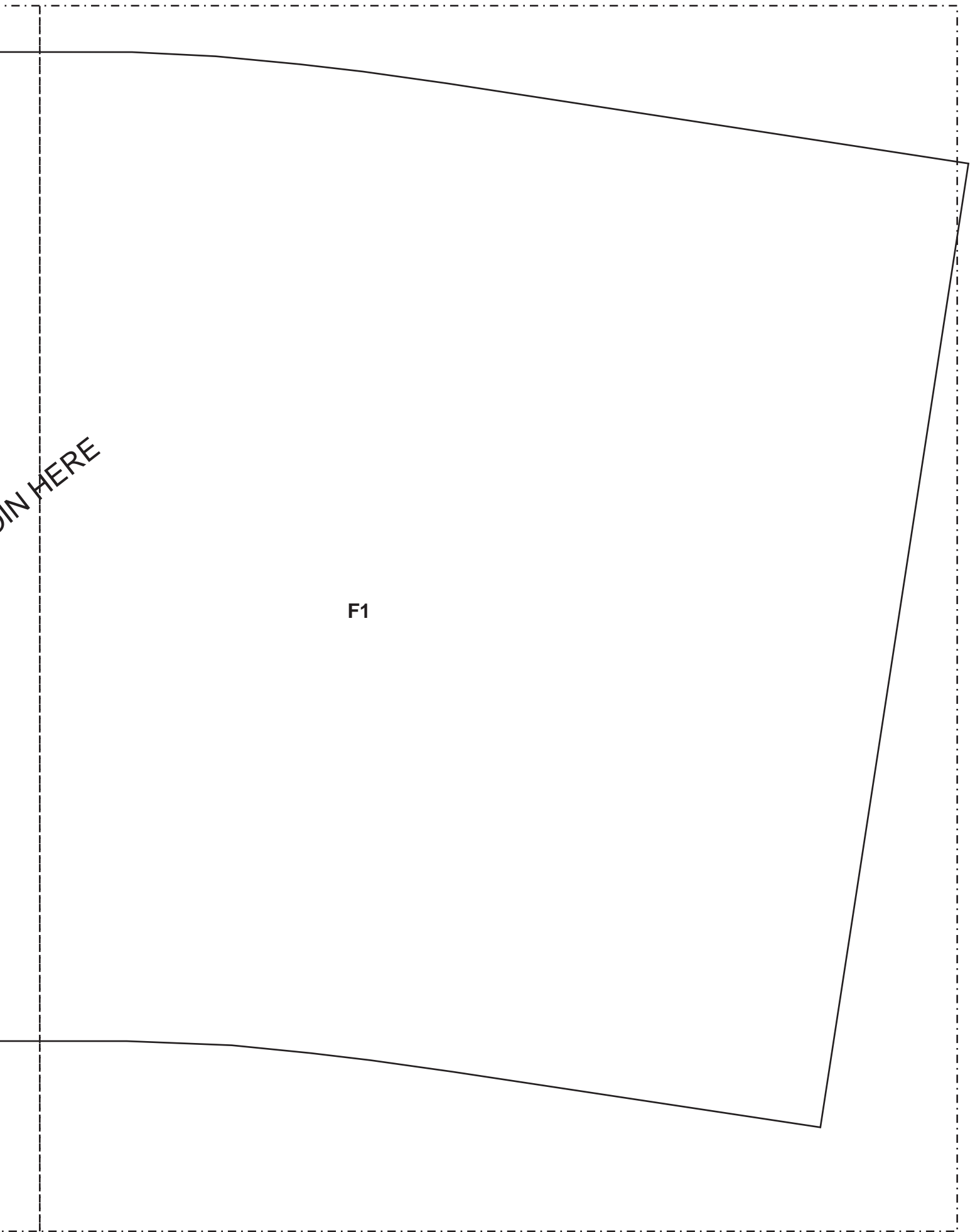

JOIN HERE

F1

**F3**

FUSELAGE  
POLYFOAM/  
DEPRON 5MM  
2X MIRRORED



UPWARD

FRONT



**F2**

FUSELAGE FORMER  
POLYFOAM/  
DEPRON 5MM

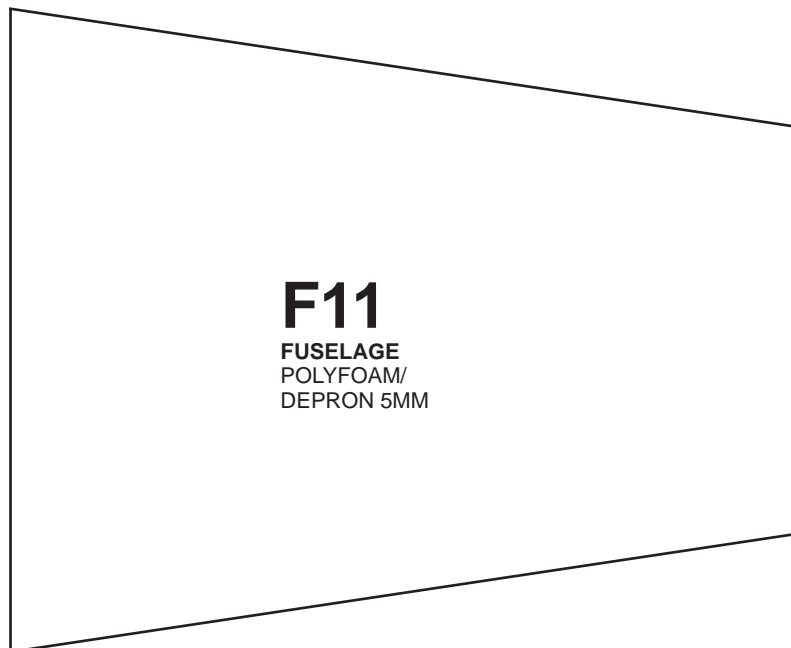

**F11**

FUSELAGE  
POLYFOAM/  
DEPRON 5MM

**F4**

FUSELAGE  
POLYFOAM/  
DEPRON 5MM



UPWARD

FRONT



**FRONT LANDING GEAR**

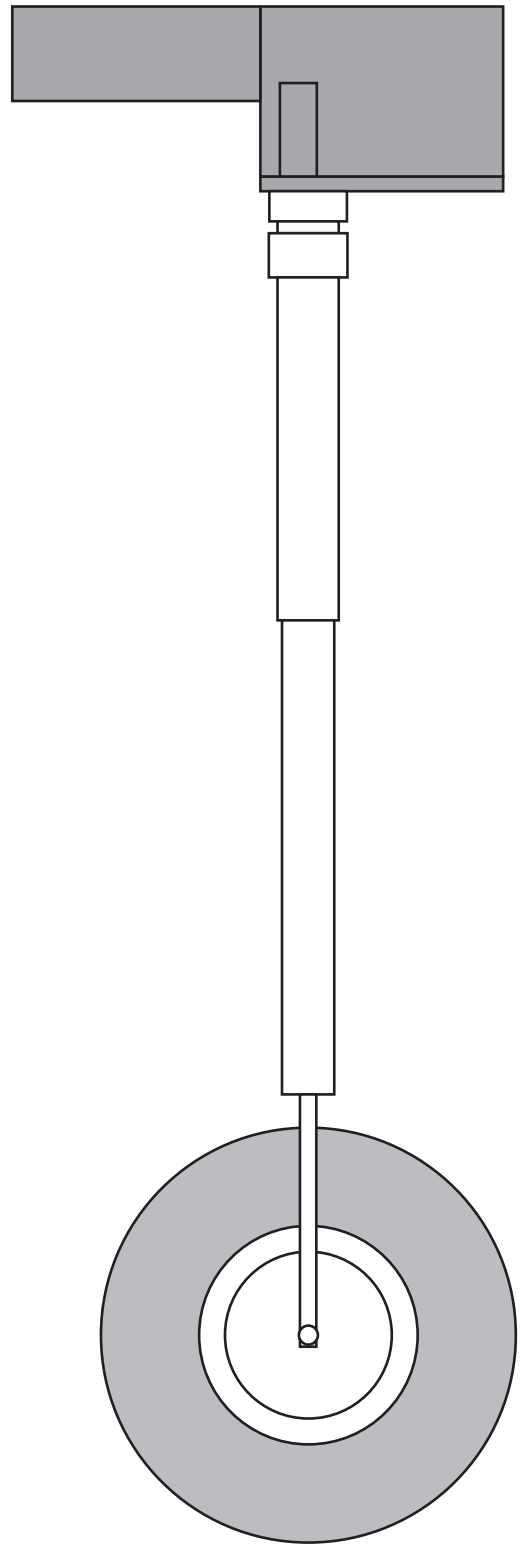

**F7**

FUSELAGE  
POLYFOAM/  
DEPRON 5MM  
2X MIRRORED



FRONT



**F5**

FUSELAGE  
POLYFOAM/  
DEPRON 5MM

JOIN HERE

JOIN HERE

F5

**F6**  
FUSELAGE FORMER  
POLYFOAM/  
DEPRON 5MM

**G1**  
NOSE PROFILE  
SIDE



**P24** MAIN LG BASE  
PLYWOOD 3MM  
2X

**F8**  
FUSELAGE  
POLYFOAM/  
DEPRON 5MM



**F9**  
FUSELAGE  
POLYFOAM/  
DEPRON 5MM

**F10**  
FUSELAGE  
POLYFOAM/  
DEPRON 5MM  
2X MIRRORED

← UP

FRONT ↓

**F29**  
FUSELAGE  
POLYFOAM/  
DEPRON 5MM  
2X

**F28**  
FUSELAGE  
POLYFOAM/  
DEPRON 5MM



# F12

FUSELAGE  
POLYFOAM/  
DEPRON 5MM

JOIN HERE

JOIN HERE

JOIN HERE

F12

JOIN HERE

JOIN HERE

F12

JOIN HERE

JOIN HERE

F12

JOIN HERE

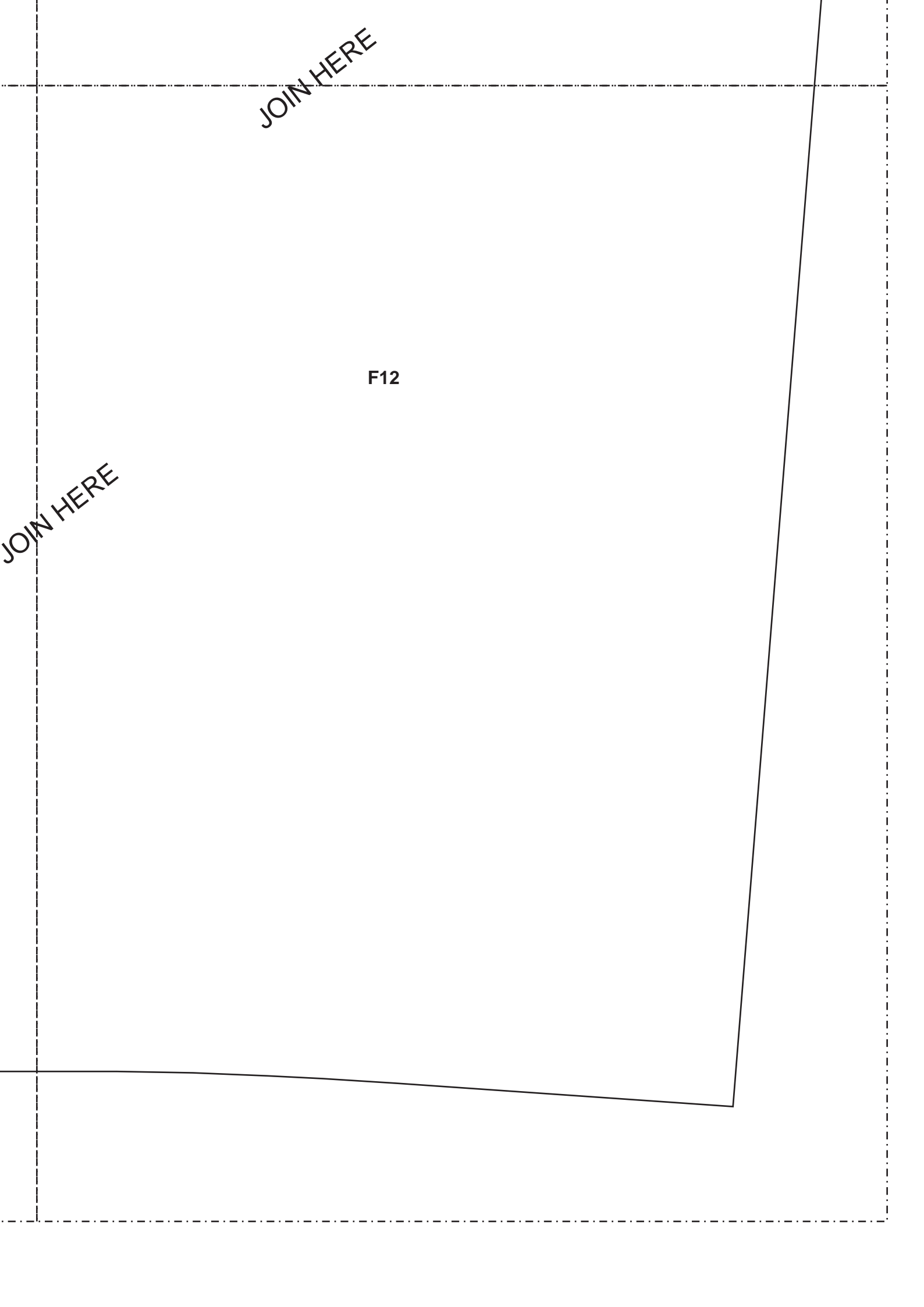

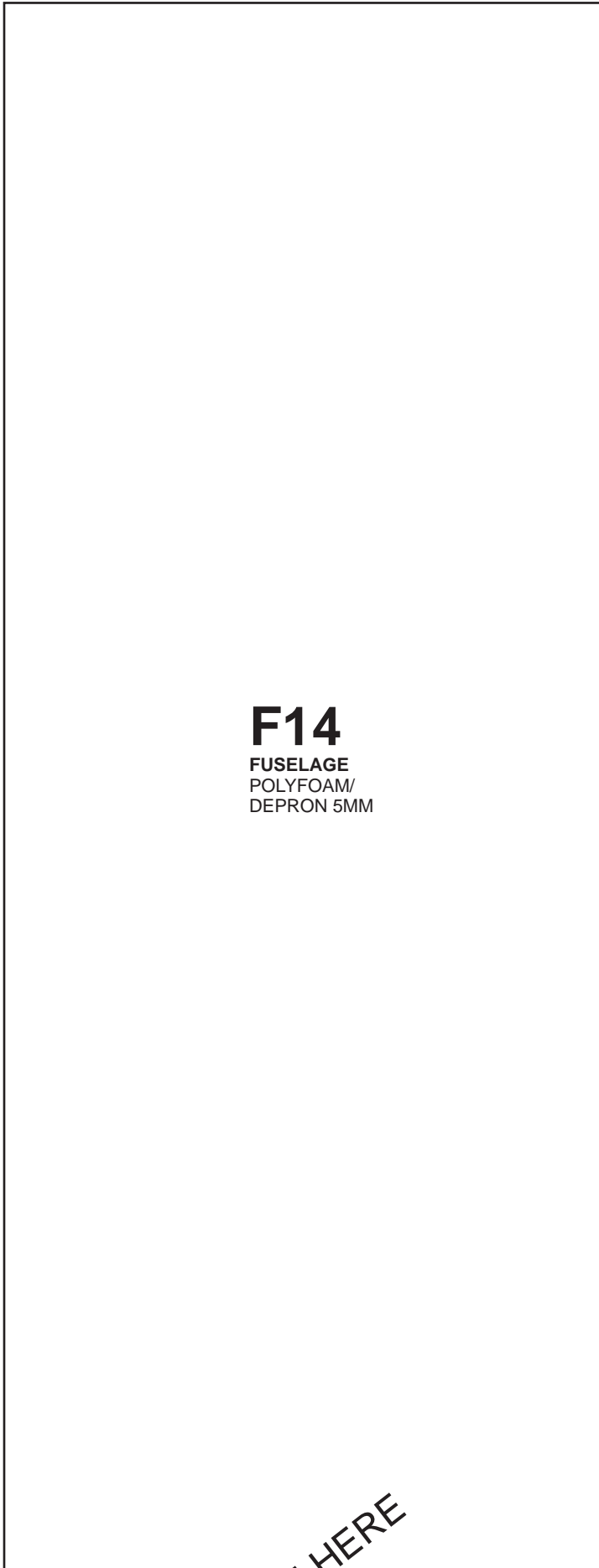

**F14**  
FUSELAGE  
POLYFOAM/  
DEPRON 5MM



**F13**  
FUSELAGE  
POLYFOAM/  
DEPRON 5MM  
2X MIRRORED



**P3**  
FRONT LG BASE  
PLYWOOD 3MM  
2X

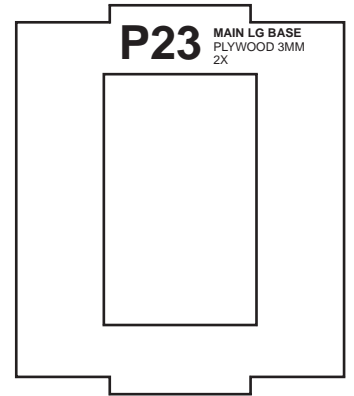

**P23** MAIN LG BASE  
PLYWOOD 3MM  
2X

JOIN HERE

JOIN HERE

JOIN HERE

JOIN HERE

F14

F13

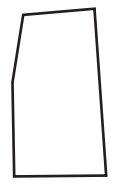

**P27**  
OUTER WING  
PLYWOOD 3MM  
2X



**F15**

FUSELAGE  
POLYFOAM/  
DEPRON 5MM

JOIN HERE



**F16**

FUSELAGE FORMER  
POLYFOAM/  
DEPRON 5MM



**F19**

FUSELAGE FORMER  
POLYFOAM/  
DEPRON 5MM

JOIN HER

JOIN HERE

**F14**

**G1**  
NOSE PROFILE  
TOP

JOIN HERE

**F18**

**F18**  
FUSELAGE  
POLYFOAM/  
DEPRON 5MM



FRONT



UP

**F17**  
FUSELAGE  
POLYFOAM/  
DEPRON 5MM  
2X MIRRORED



# F20

FUSELAGE  
POLYFOAM/  
DEPRON 5MM

JOIN HERE

JOIN HERE

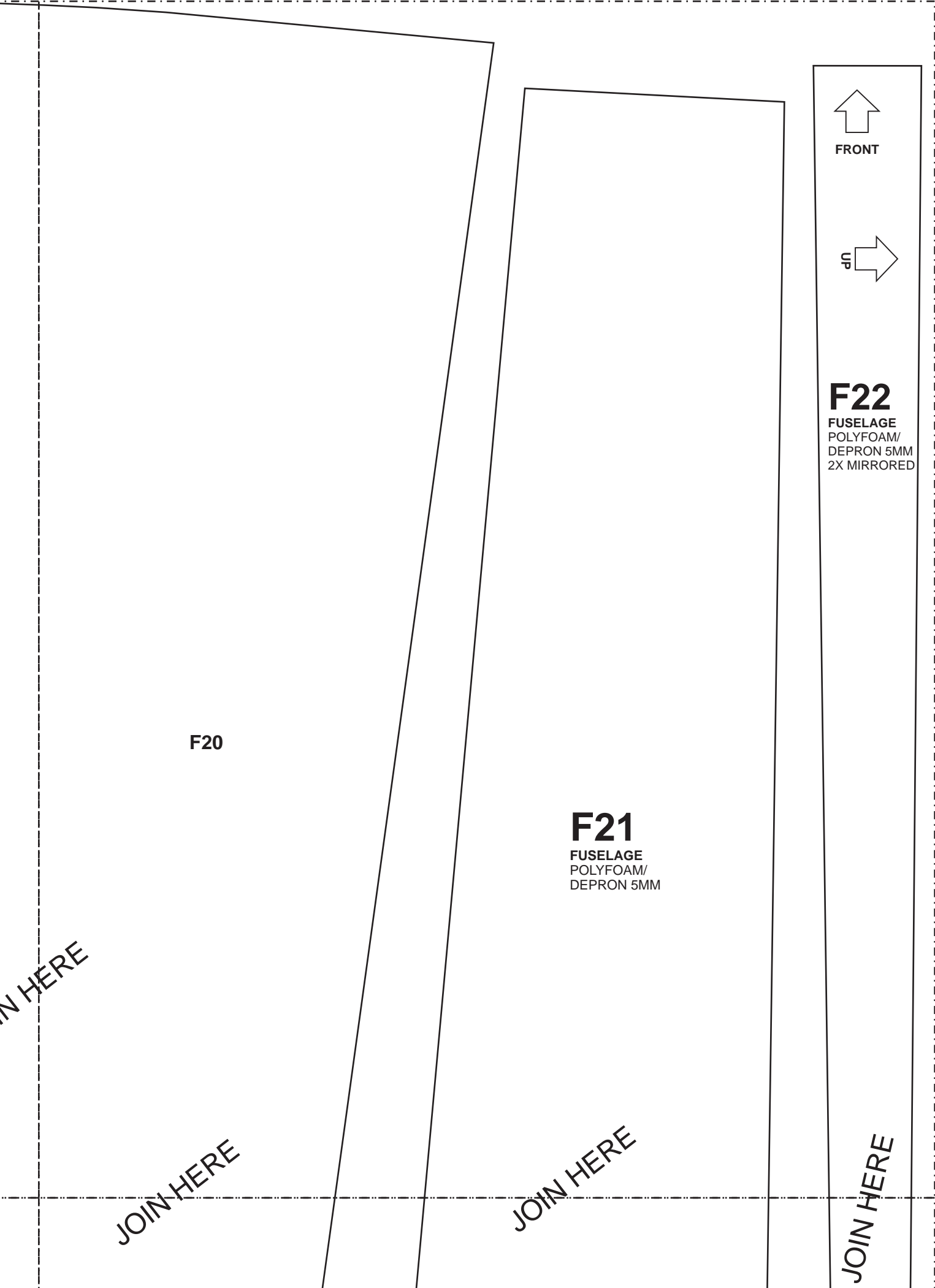

**F20**

**F21**

FUSELAGE  
POLYFOAM/  
DEPRON 5MM



FRONT



**F22**

FUSELAGE  
POLYFOAM/  
DEPRON 5MM  
2X MIRRORED

JOIN HERE

JOIN HERE

JOIN HERE

JOIN HERE

JOIN HERE

JOIN HERE

F20

F31

**F30**  
FUSELAGE ACC  
POLYFOAM/  
DEPRON 5MM

**P25**  
MAIN LG BASE  
PLYWOOD 3MM  
4X

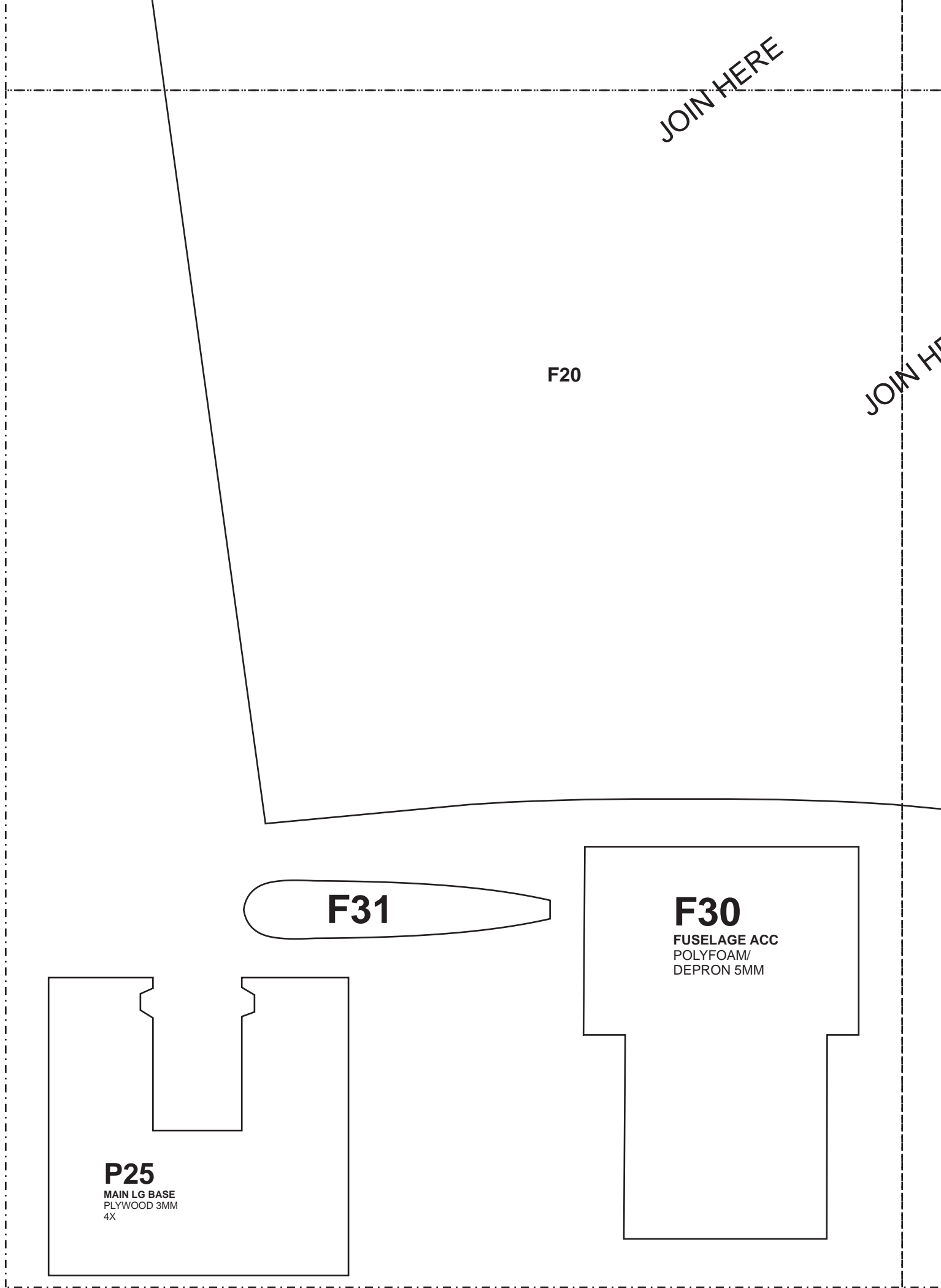

JOIN HERE

JOIN HERE

JOIN HERE

F20

F22

F21

JOIN HERE

**W16**

ORDNANCE PYLON  
POLYFOAM/  
DEPRON 5MM  
10X

**P29**

OUTER WING  
PLYWOOD 3MM  
2X

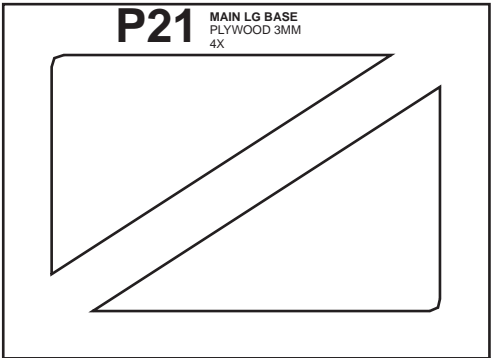
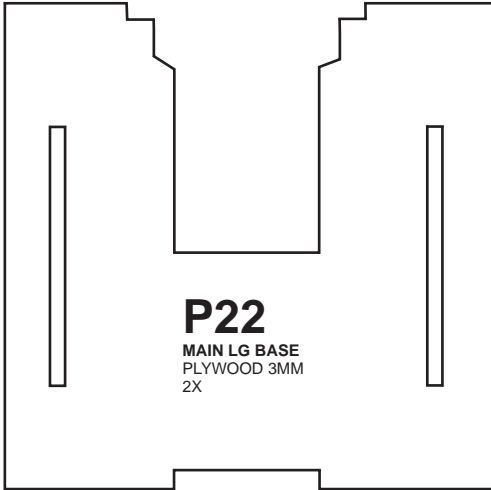
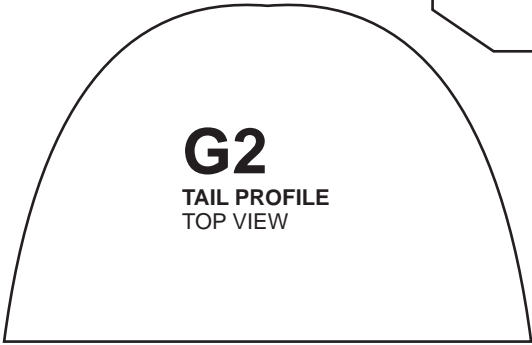
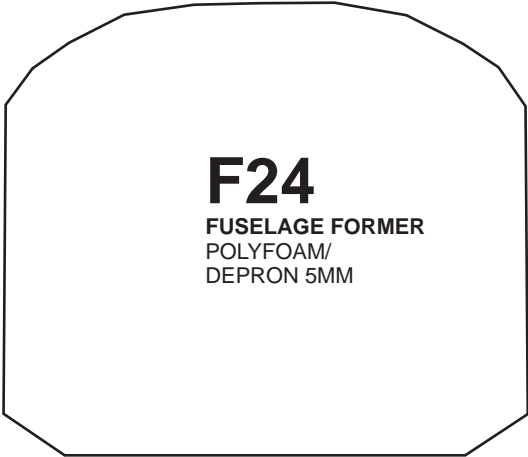
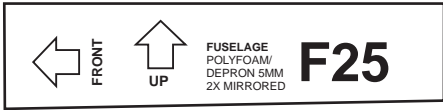
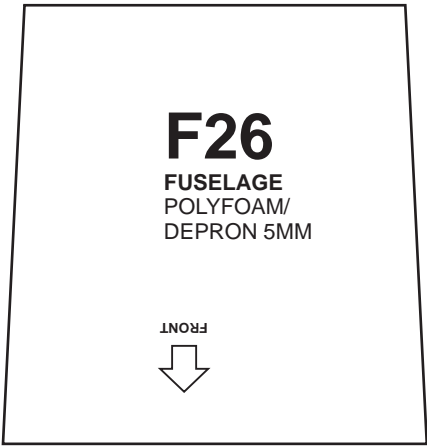
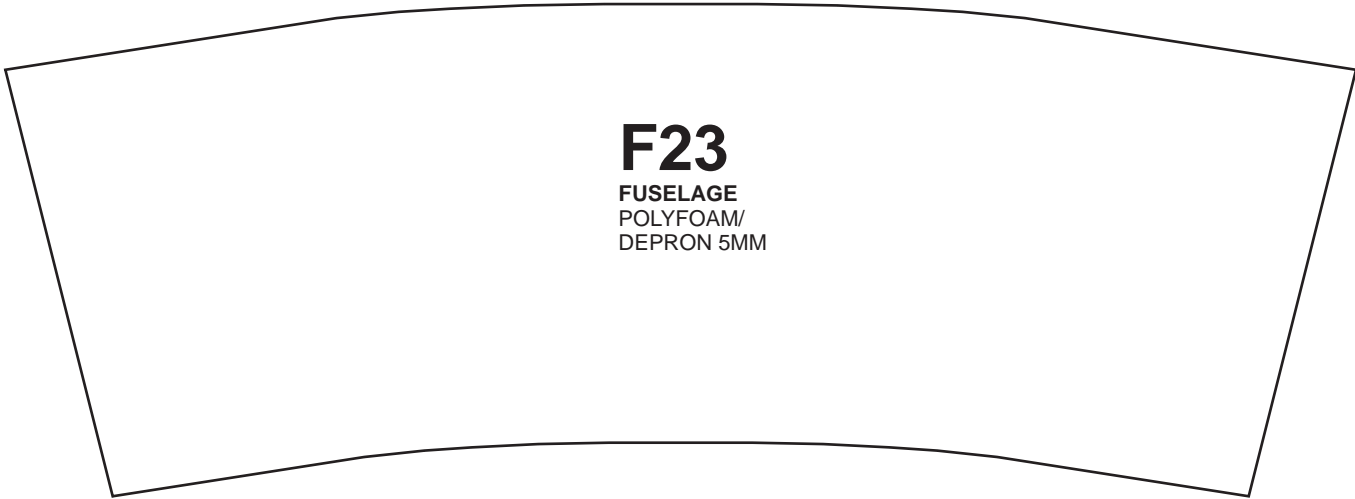

**S1**

HOR-STAB  
POLYFOAM/  
DEPRON 5MM  
3X

**P9**

WING ROOT SPAR  
PLYWOOD 3MM  
1X

**P8**

WING ROOT SPAR  
PLYWOOD 3MM  
1X

JOIN HERE

JOIN HERE

S1

**P18**  
INNER WING  
PLYWOOD 3MM  
2X

JOIN HERE

JOIN HERE

S1

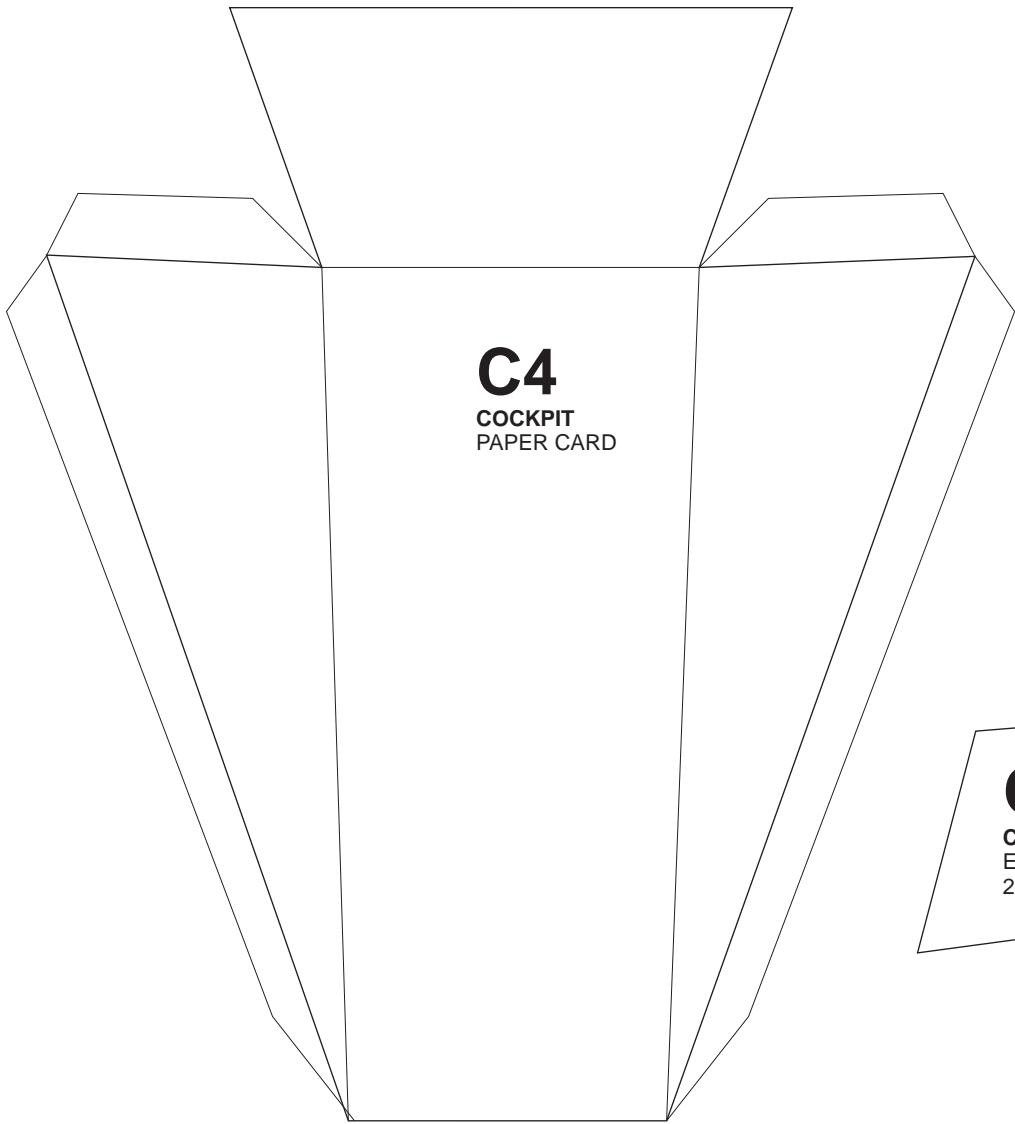

**C4**  
COCKPIT  
PAPER CARD

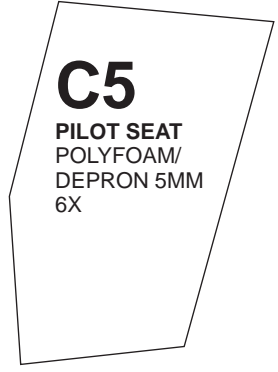

**C5**  
PILOT SEAT  
POLYFOAM/  
DEPRON 5MM  
6X

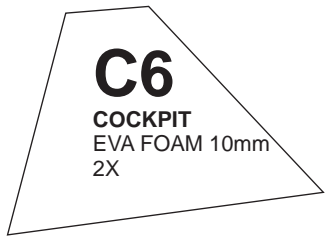

**C6**  
COCKPIT  
EVA FOAM 10mm  
2X





**S3**

VER-STAB  
POLYFOAM/  
DEPRON 5MM  
4X

JOIN HERE



**P4**

FRONT LG BASE  
PLYWOOD 3MM  
1X

IN HERE

**P10**  
WING ROOT SPAR  
PLYWOOD 3MM  
1X

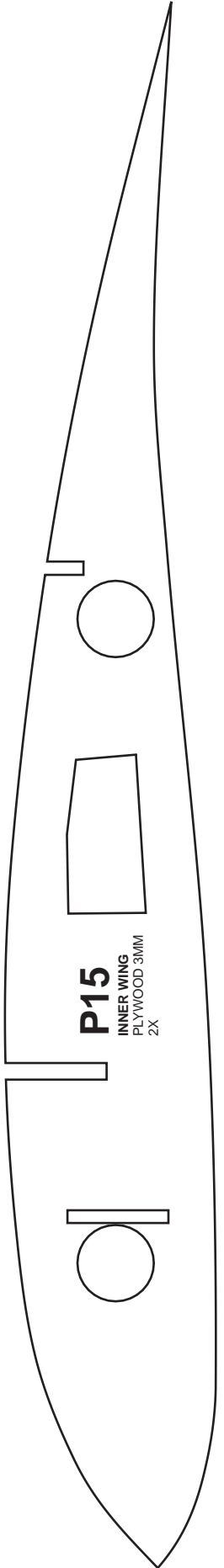
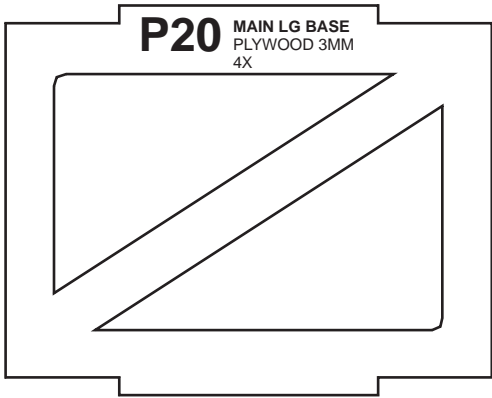
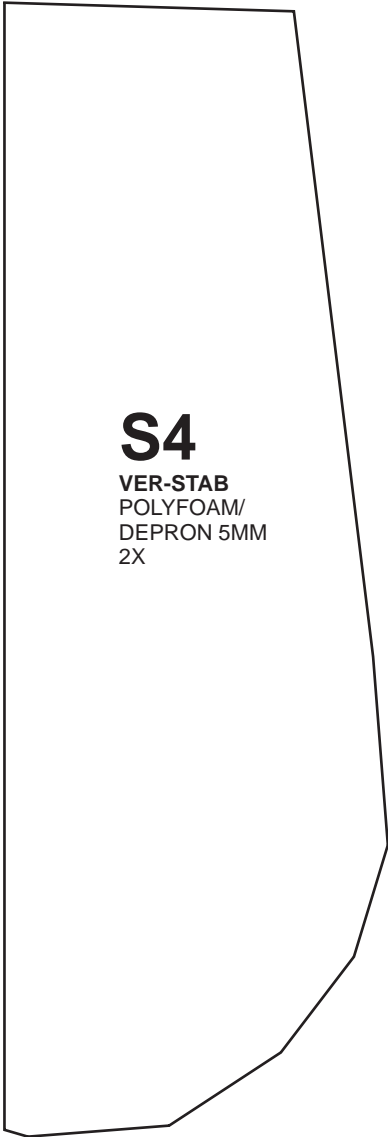
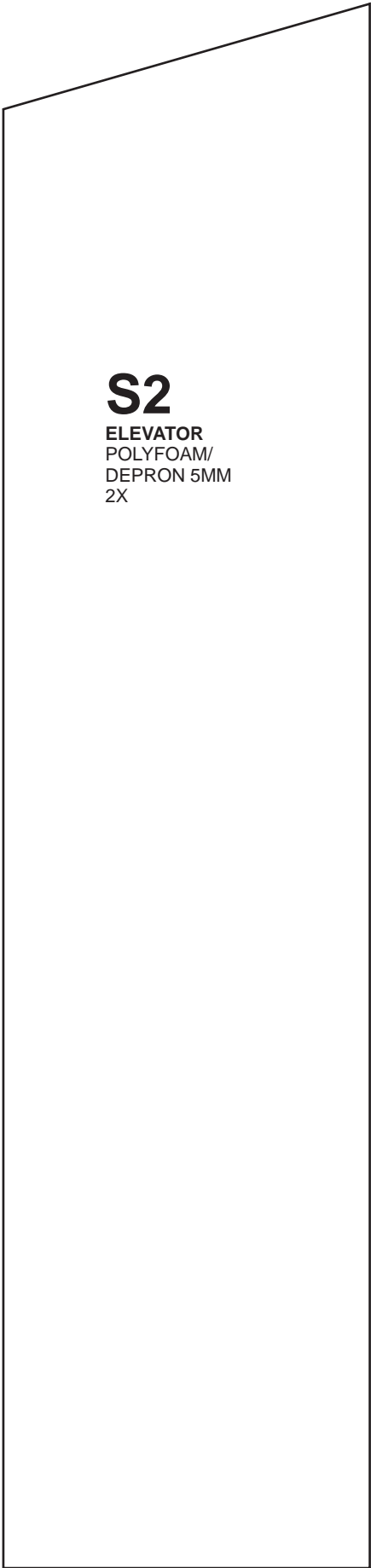

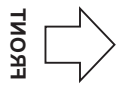
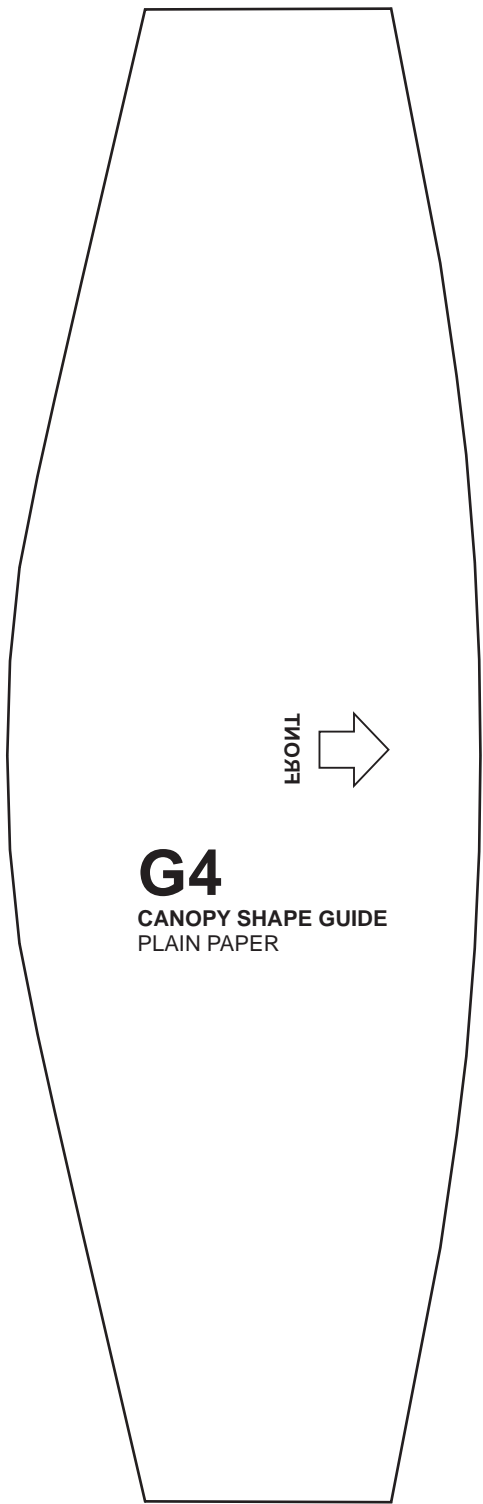

**G4**  
CANOPY SHAPE GUIDE  
PLAIN PAPER

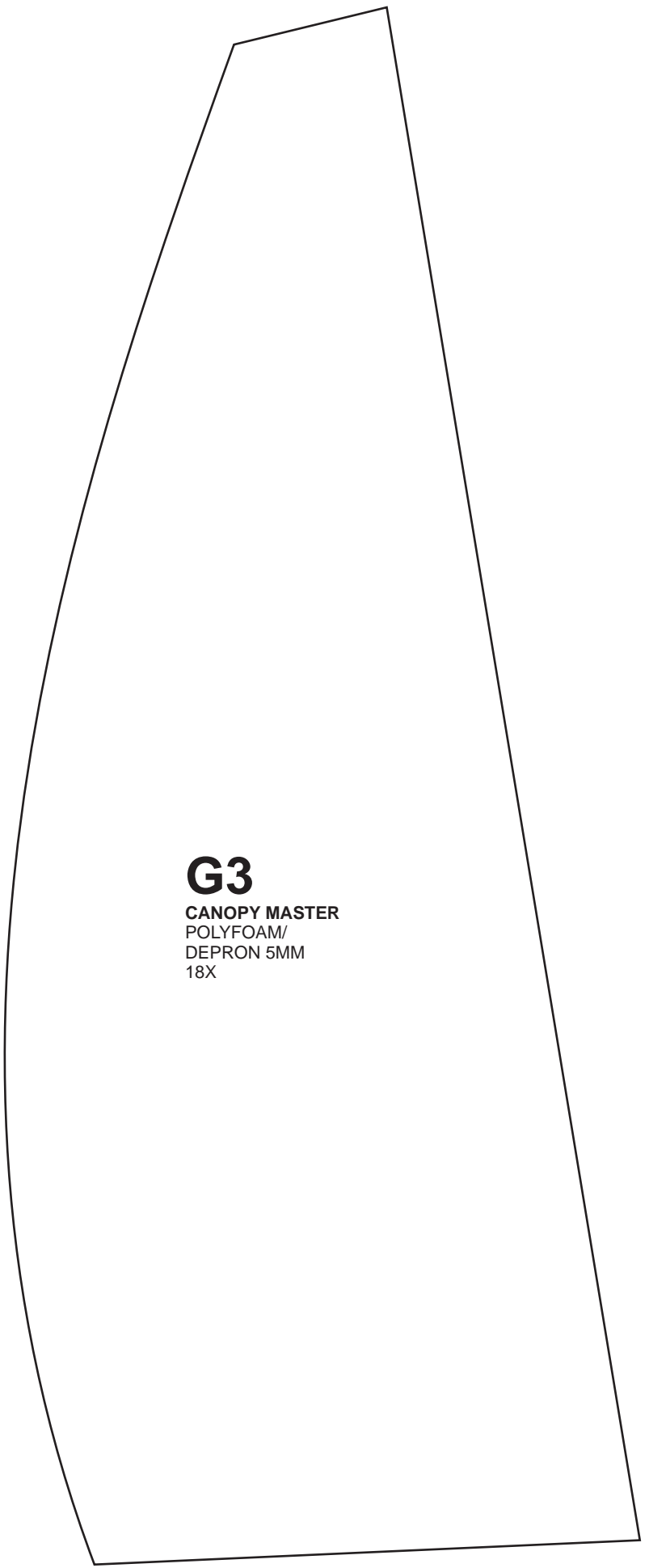

**G3**  
CANOPY MASTER  
POLYFOAM/  
DEPRON 5MM  
18X

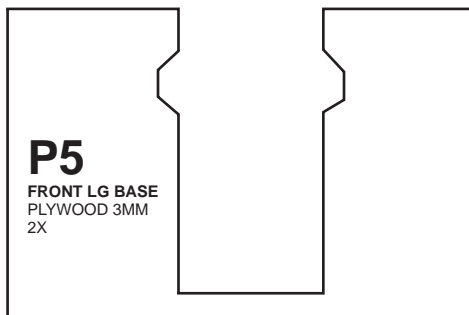

**P5**  
FRONT LG BASE  
PLYWOOD 3MM  
2X

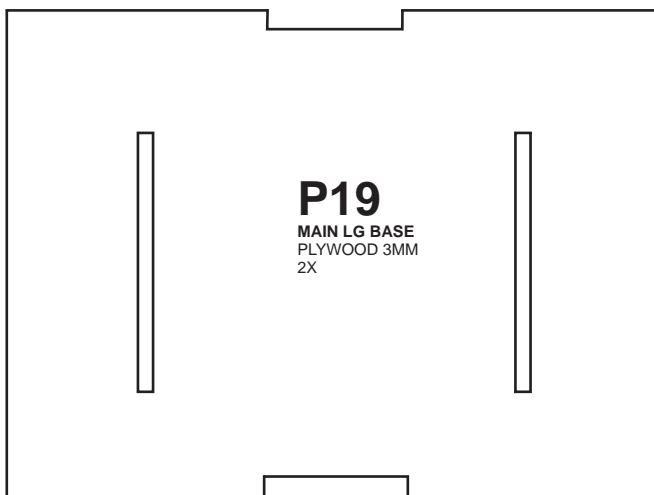
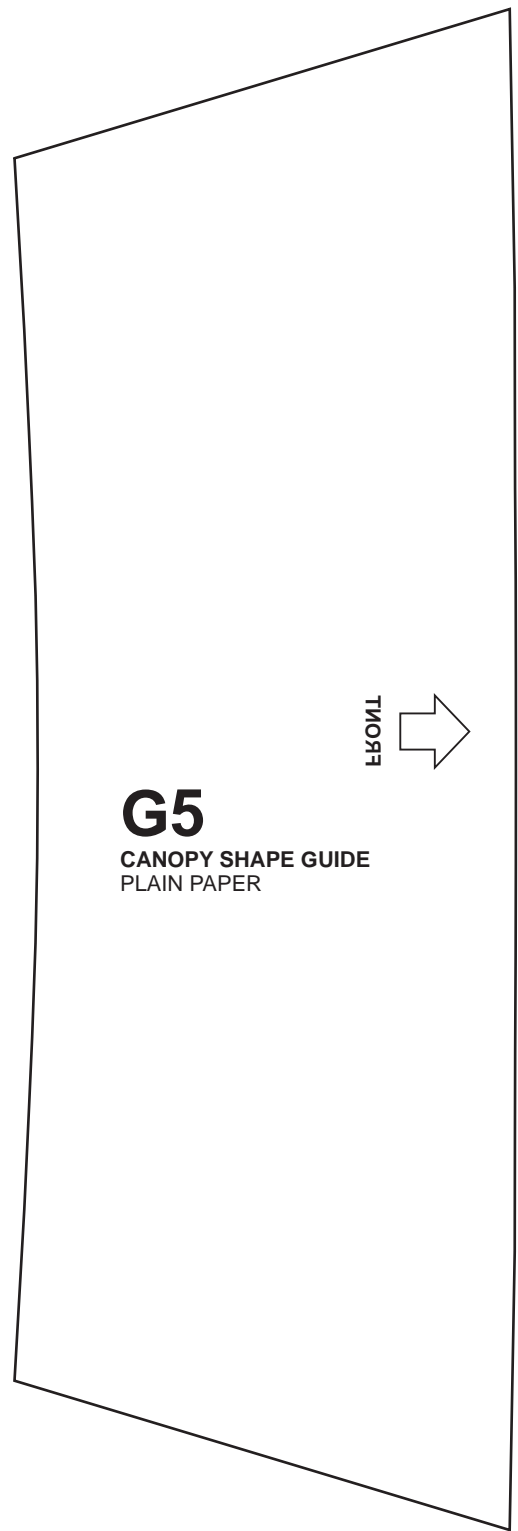
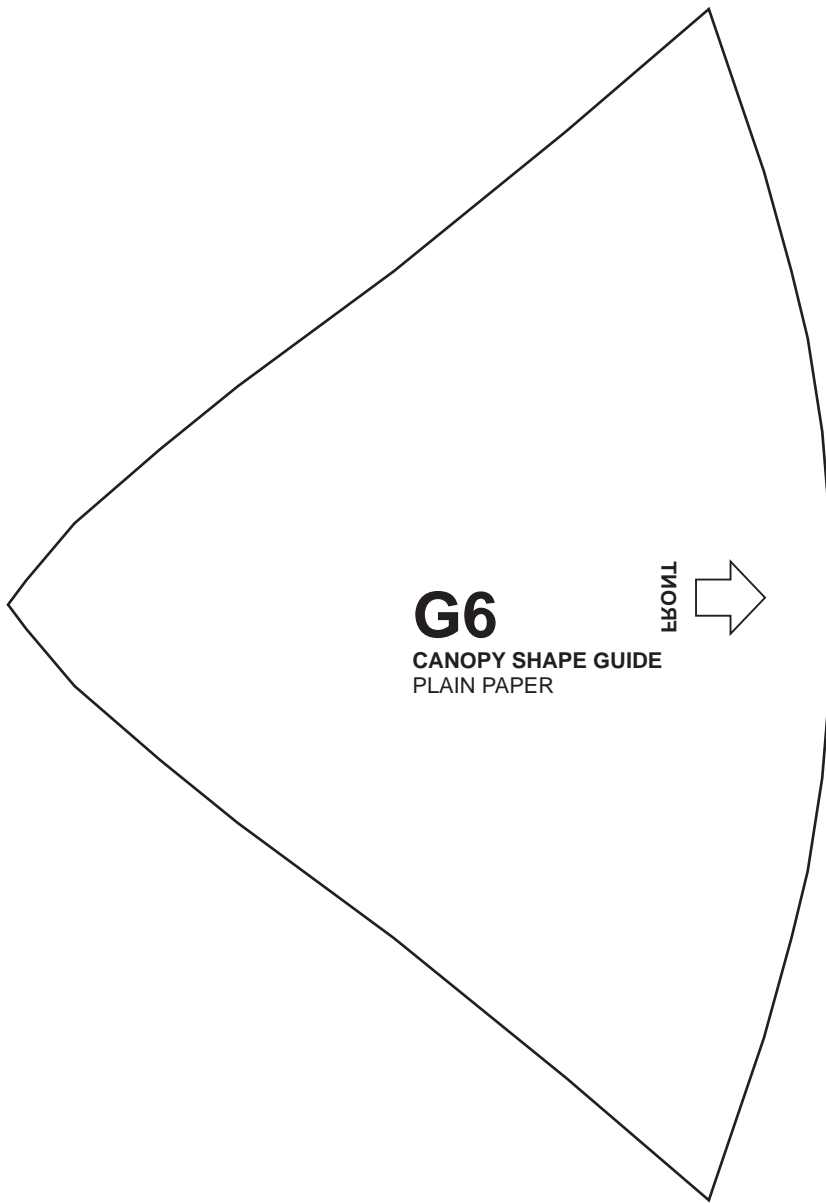

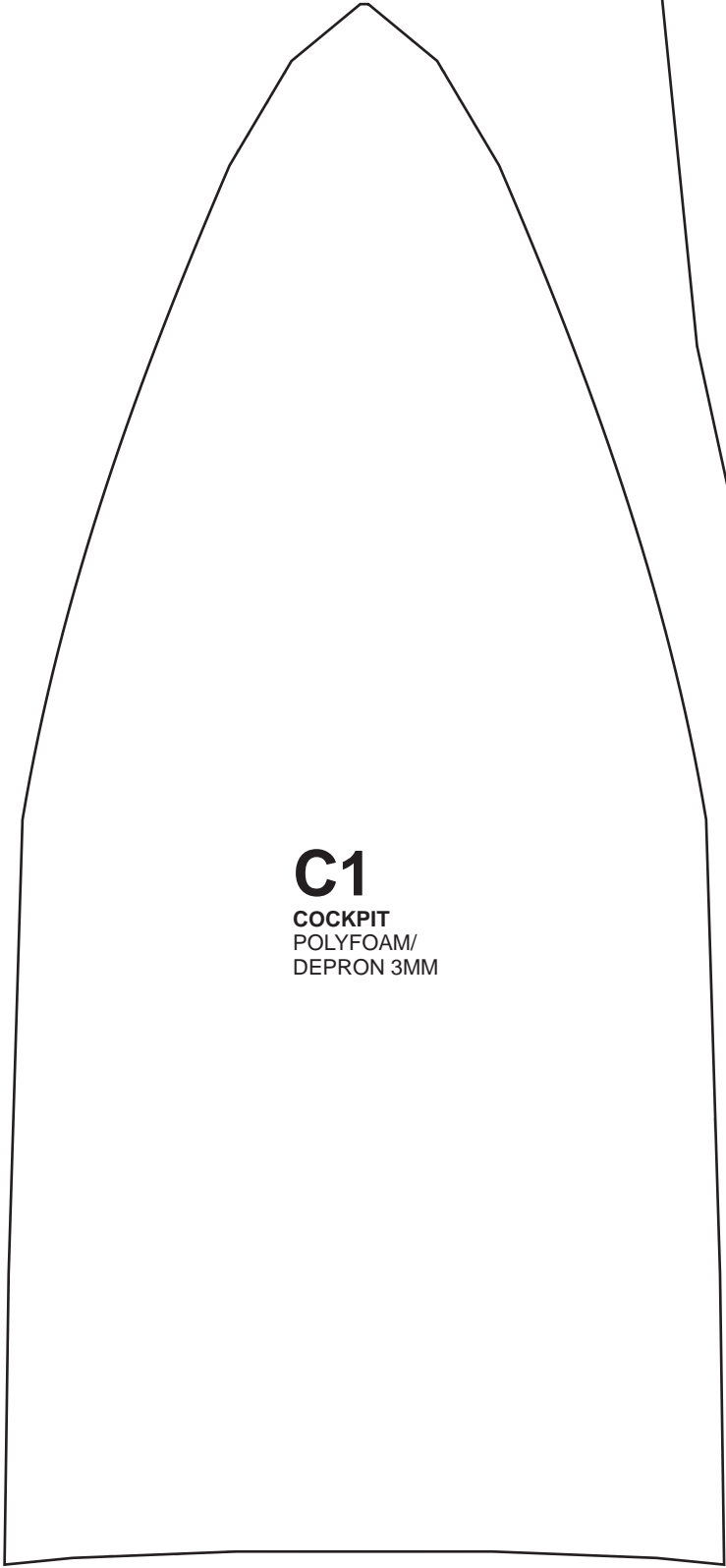

**C1**  
COCKPIT  
POLYFOAM/  
DEPRON 3MM

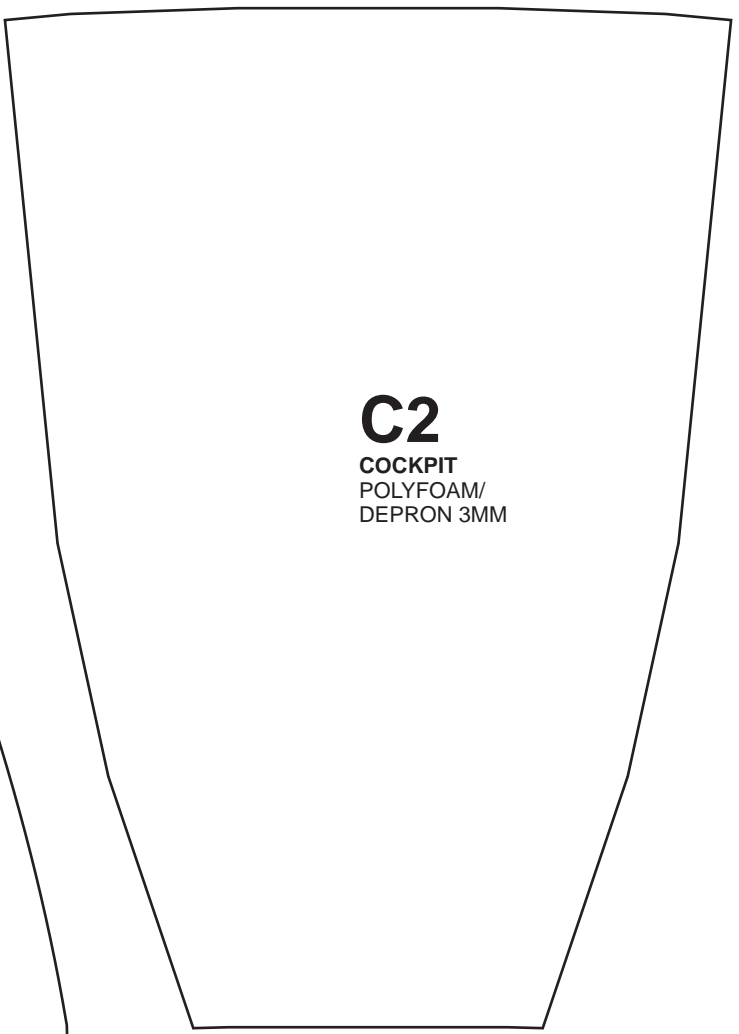

**C2**  
COCKPIT  
POLYFOAM/  
DEPRON 3MM

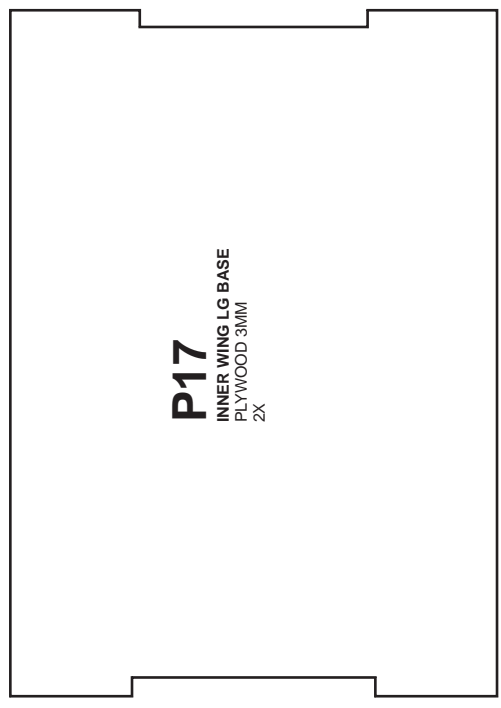

**P17**  
INNER WING LG BASE  
PLYWOOD 3MM  
2X

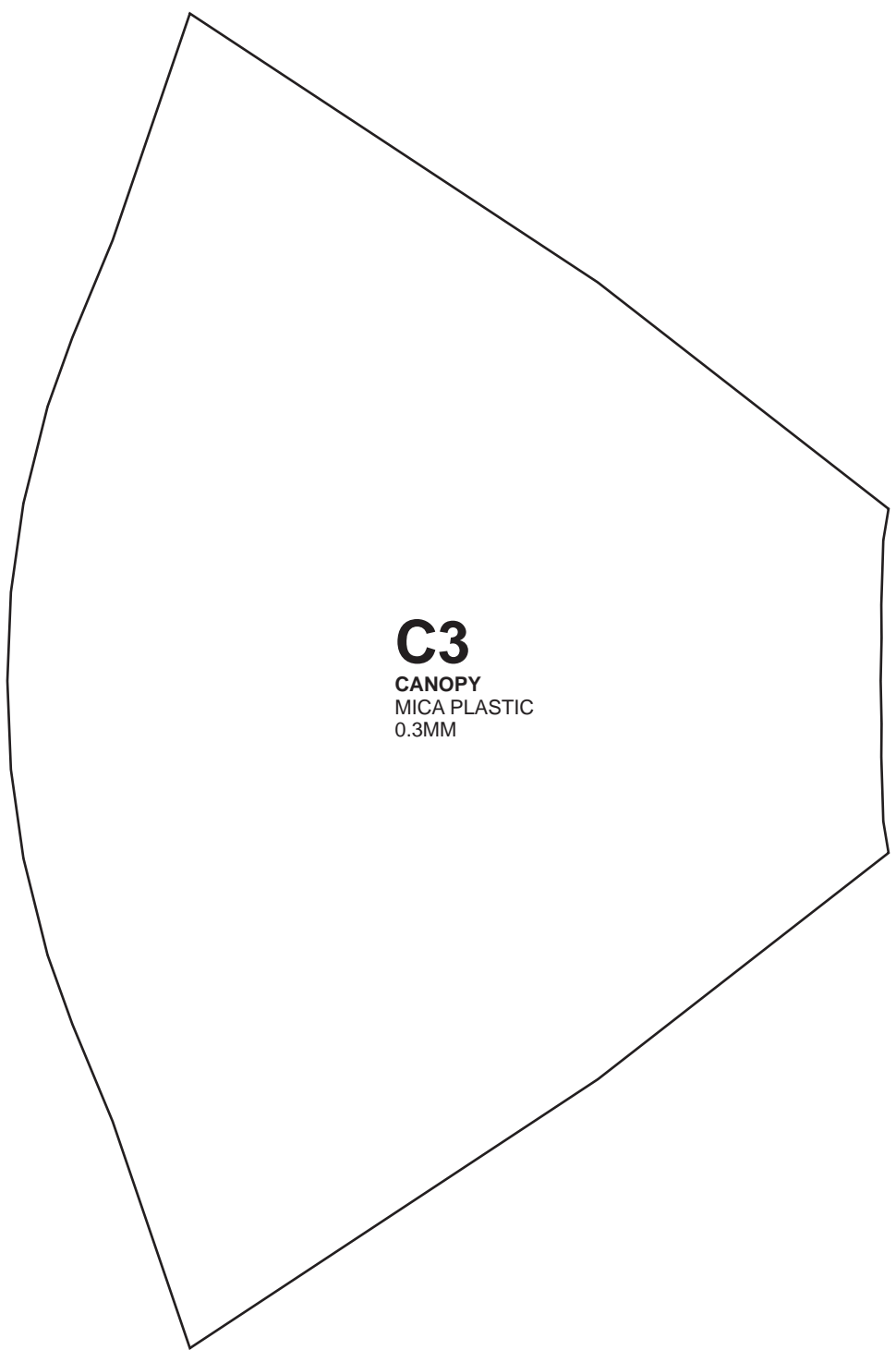

**C3**  
CANOPY  
MICA PLASTIC  
0.3MM

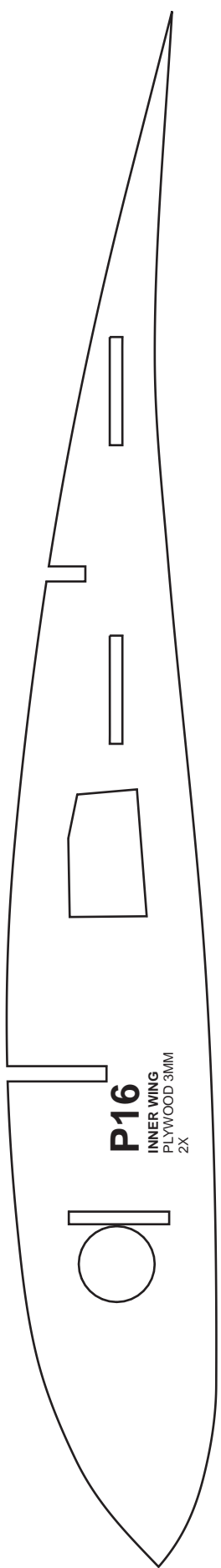

**P16**  
INNER WING  
PLYWOOD 3MM  
2X

# W2

WING  
POLYFOAM/  
DEPRON 5MM  
2X MIRRORED

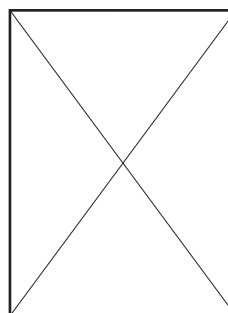

JOIN HERE

# P13

INNER WING SPAR  
PLYWOOD 3MM  
2X



IN HERE

W2

**P12**  
INNER WING SPAR  
PLYWOOD 3MM  
2X

**P14**  
INNER WING SPAR  
PLYWOOD 3MM  
2X

**W1**

**WING**  
POLYFOAM/  
DEPRON 5MM  
2X MIRRORED

JOIN HERE

JOIN HERE

W1

**G7**

FUSELAGE WING HOLE  
PLAIN PAPER

JOIN HERE

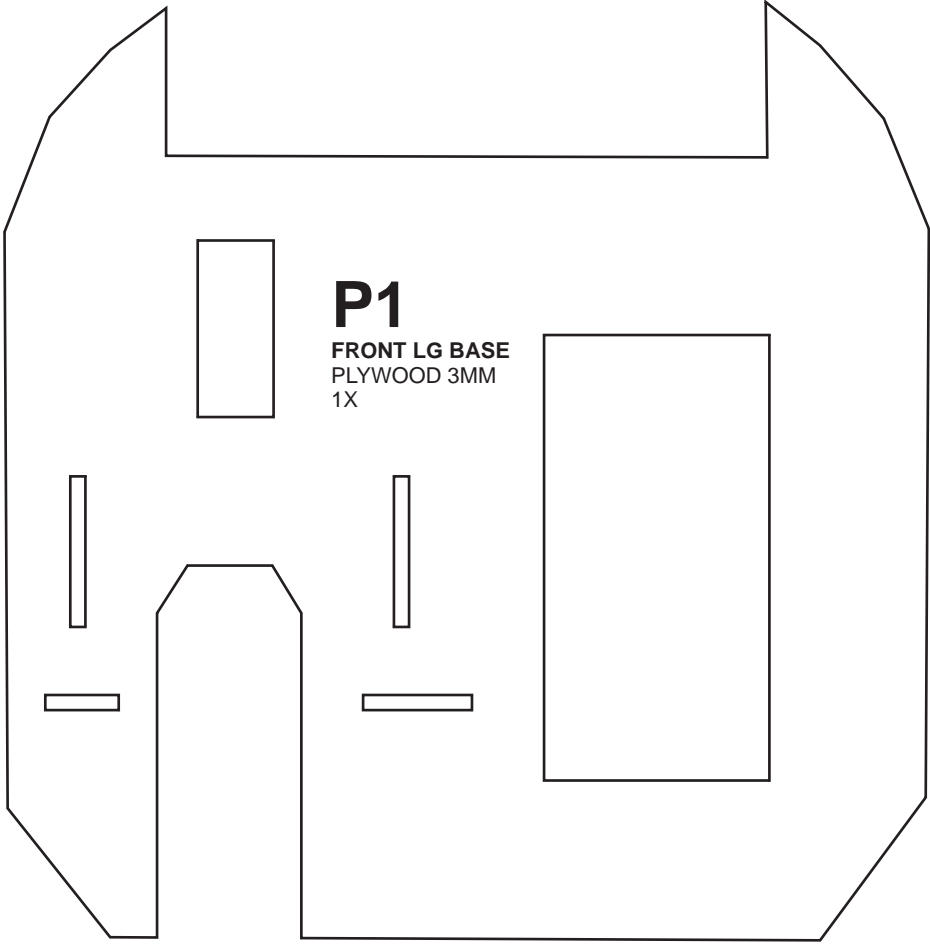
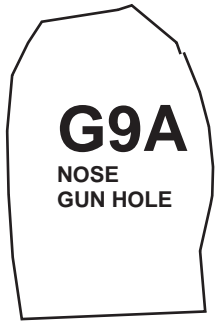
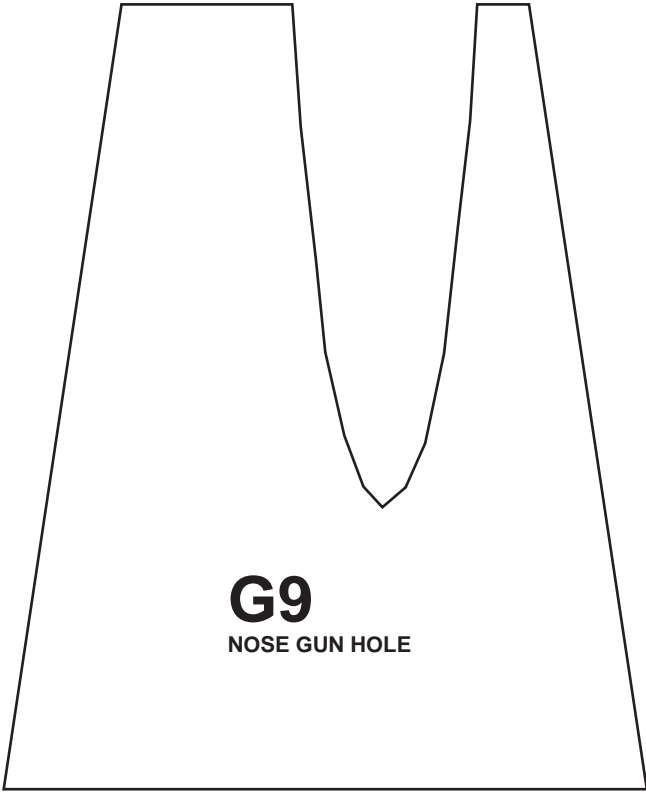
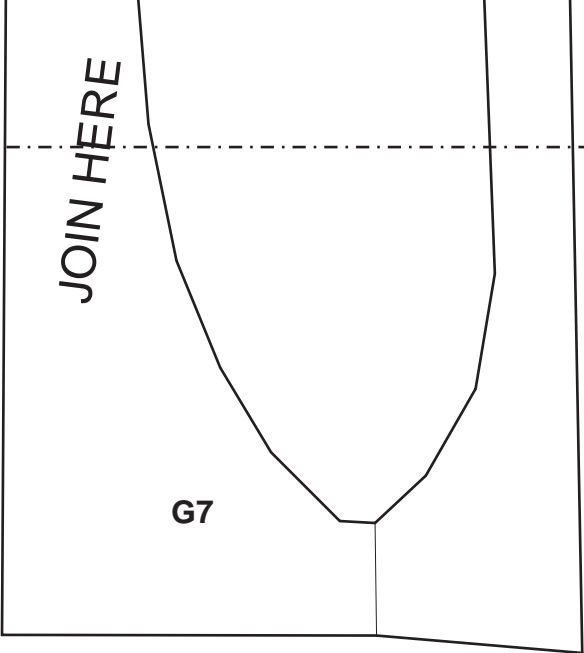

JOIN HERE

# W3

WING  
POLYFOAM/  
DEPRON 5MM  
2X MIRRORED

JOIN HERE

W3

**P7**  
WING ROOT  
PLYWOOD 3MM  
2X

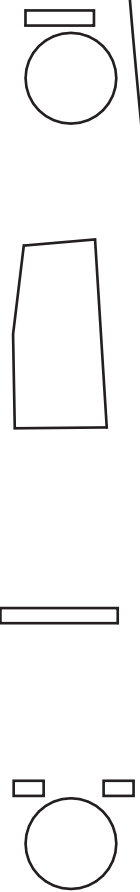

**W4**

**WING**  
POLYFOAM/  
DEPRON 5MM  
2X MIRRORED

JOIN HERE

JOIN HERE

W4

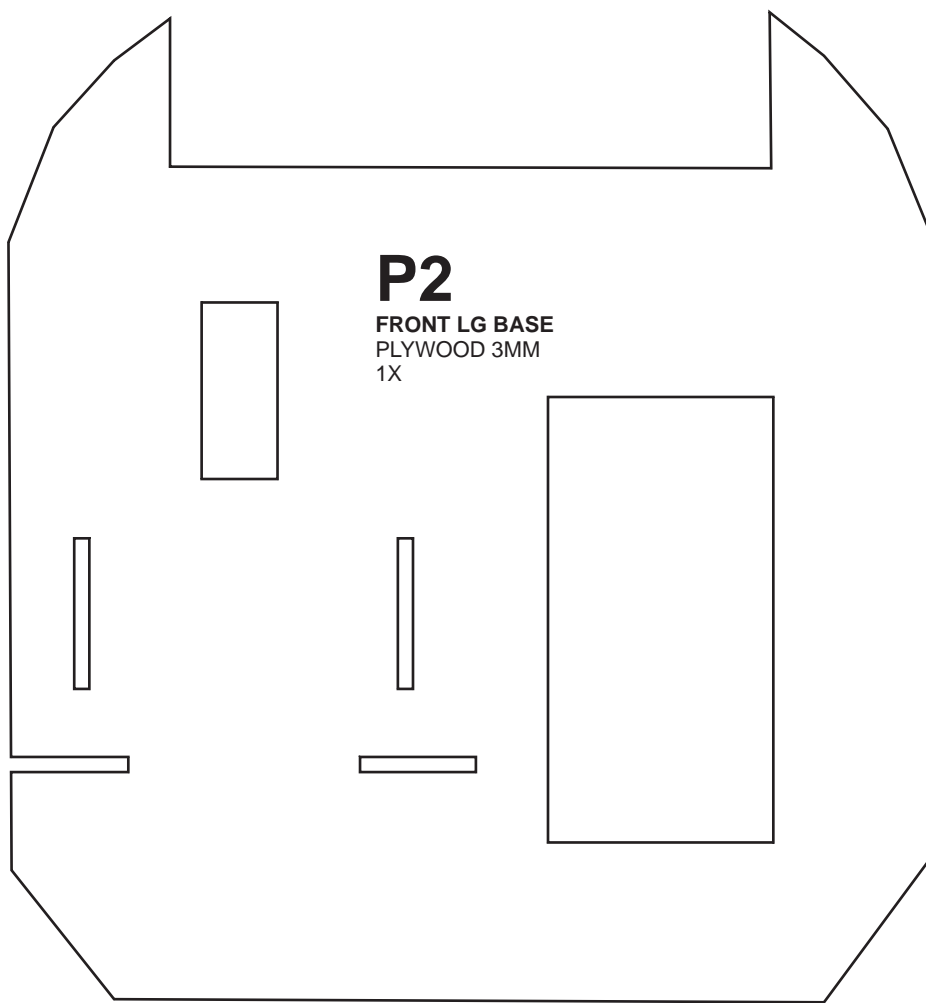



**P11**  
INNER WING  
PLYWOOD 3MM  
2X

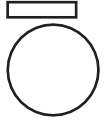
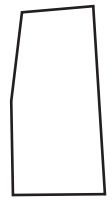
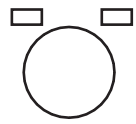
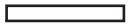

W5

JOIN HERE

JOIN HERE

**P28**  
OUTER WING SPAR  
PLYWOOD 3MM  
2X

W5

JOIN HERE

JOIN HERE

JOIN HERE

JOIN HER

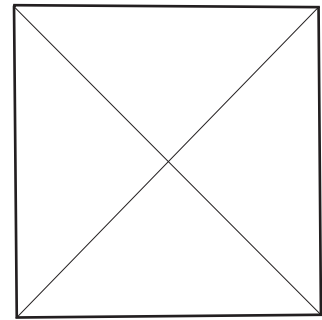

**W5**

WING  
POLYFOAM/  
DEPRON 5MM  
2X MIRRORED

JOIN HERE

JOIN HERE

JOIN HERE

W5

P28

JOIN HERE

P28

JOIN HERE

W5

JOIN HERE

JOIN HERE

P28

**W6**

WING  
POLYFOAM/  
DEPRON 5MM  
2X MIRRORED

W5

JOIN HERE

JOIN HERE

JOIN HERE

W6

**F27**

**WING FAIRING**  
MICA PLASTIC  
0.3MM / PAPER CARD  
2X MIRRORED

**F28**

**FINS**  
POLYFOAM/  
DEPRON 5MM  
2X

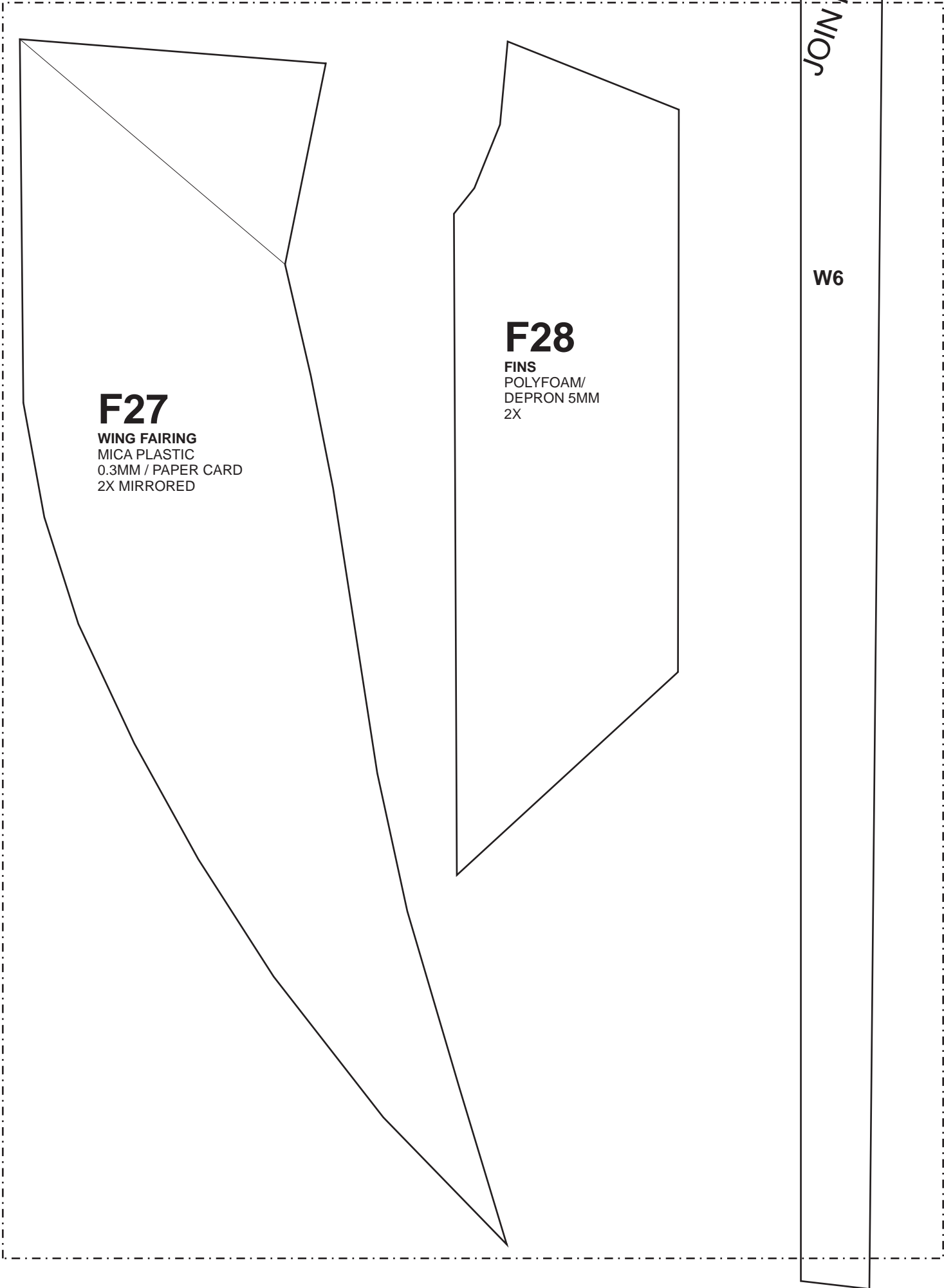

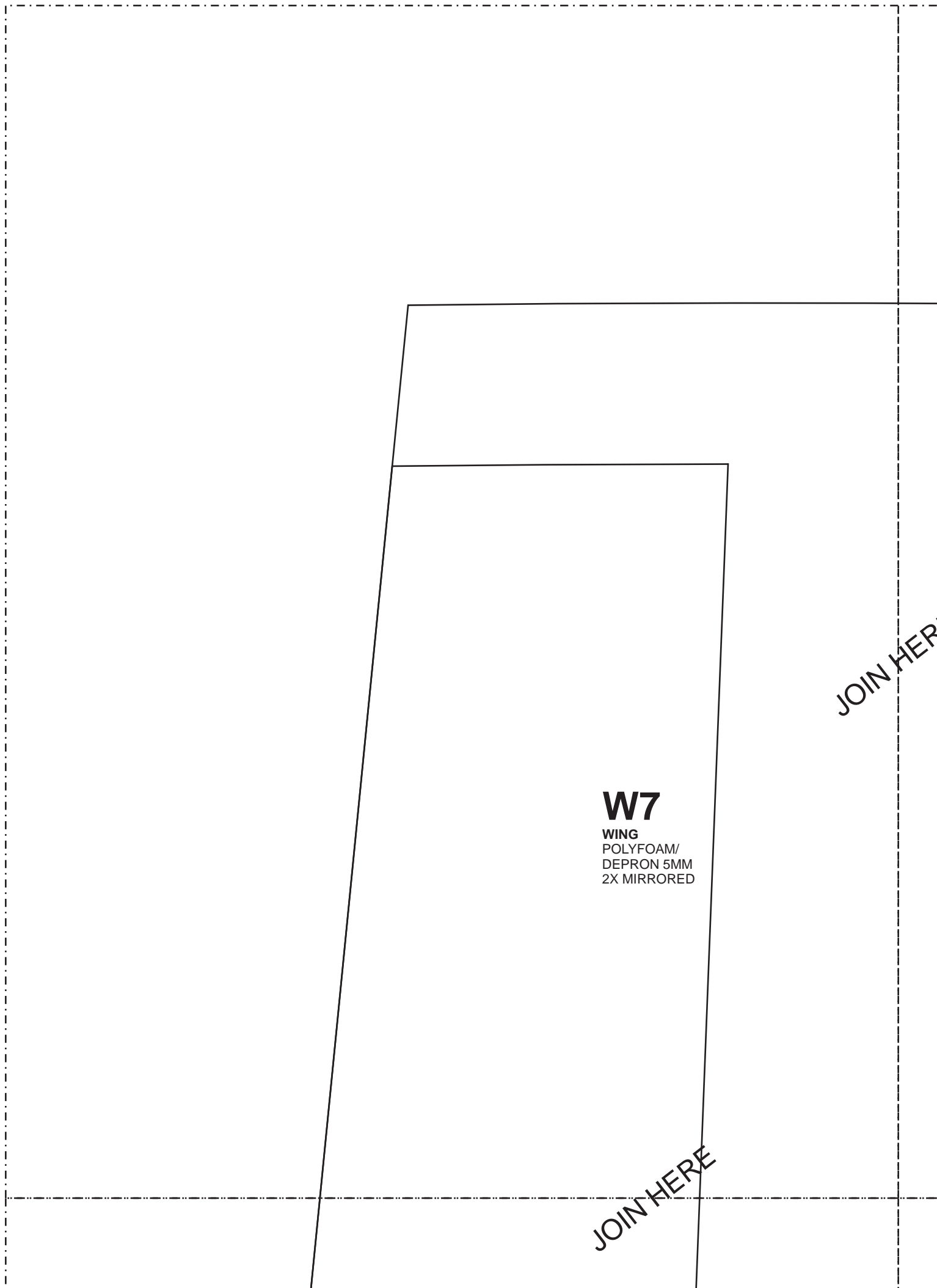

**W7**

**WING**  
POLYFOAM/  
DEPRON 5MM  
2X MIRRORED

JOIN HERE

JOIN HERE



JOIN HERE

W7

JOIN HERE

JOIN HERE

JOIN HERE

W7

JOIN HERE

JOIN HERE

JOIN HERE

W7

JOIN HERE

JOIN HERE

W7

JOIN HERE

**MAIN LANDING GEAR**

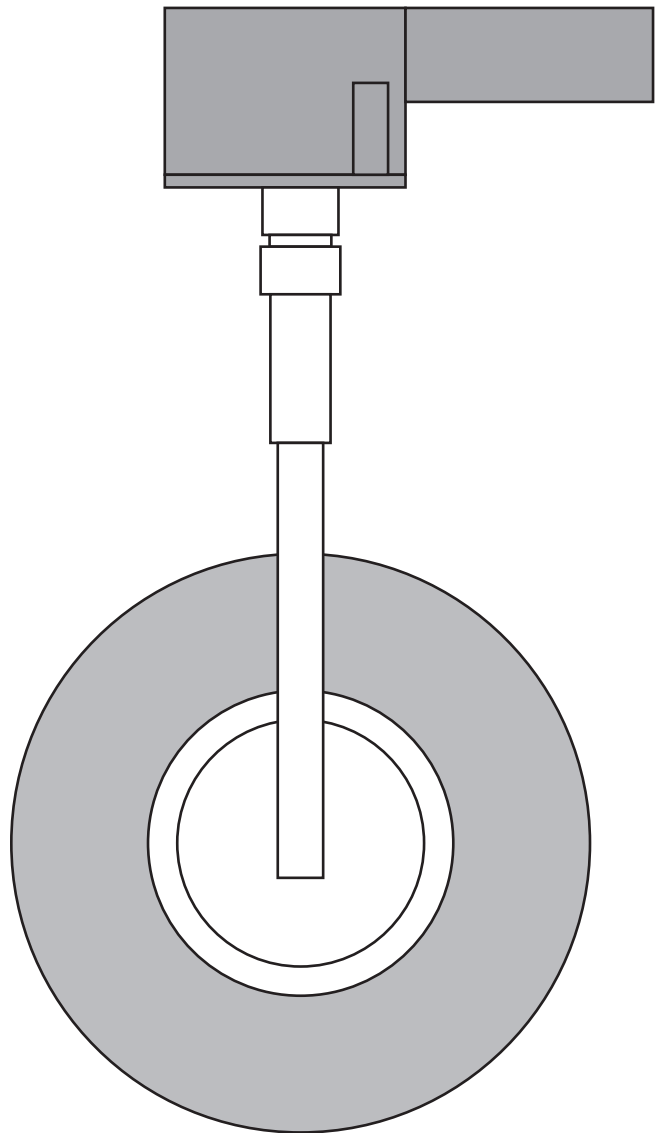

JOIN HERE

JOIN HERE

W7

**W8**

WING  
POLYFOAM/  
DEPRON 3MM  
2X MIRRORED

JOIN HERE

**W15**

WING  
POLYFOAM/  
DEPRON 5MM  
16X

**W9**

WING  
POLYFOAM/  
DEPRON 3MM  
2X MIRRORED

JOIN HERE

JOIN HERE

TOP

W8

**W13**

WING  
POLYFOAM/  
DEPRON 5MM  
2X

**W14**

WING  
POLYFOAM/  
DEPRON 5MM  
2X

**W16**

WING  
PAPER/ PLASTIC  
2X

**W10**

WING  
POLYFOAM/  
DEPRON 5MM  
4X MIRRORED

**W12**

WING FORMER  
POLYFOAM/  
DEPRON 5MM  
2X

**W11**

WING  
POLYFOAM/  
DEPRON 5MM  
2X

JOIN HERE

JOIN HERE

W10

JOIN HERE

W9

P6

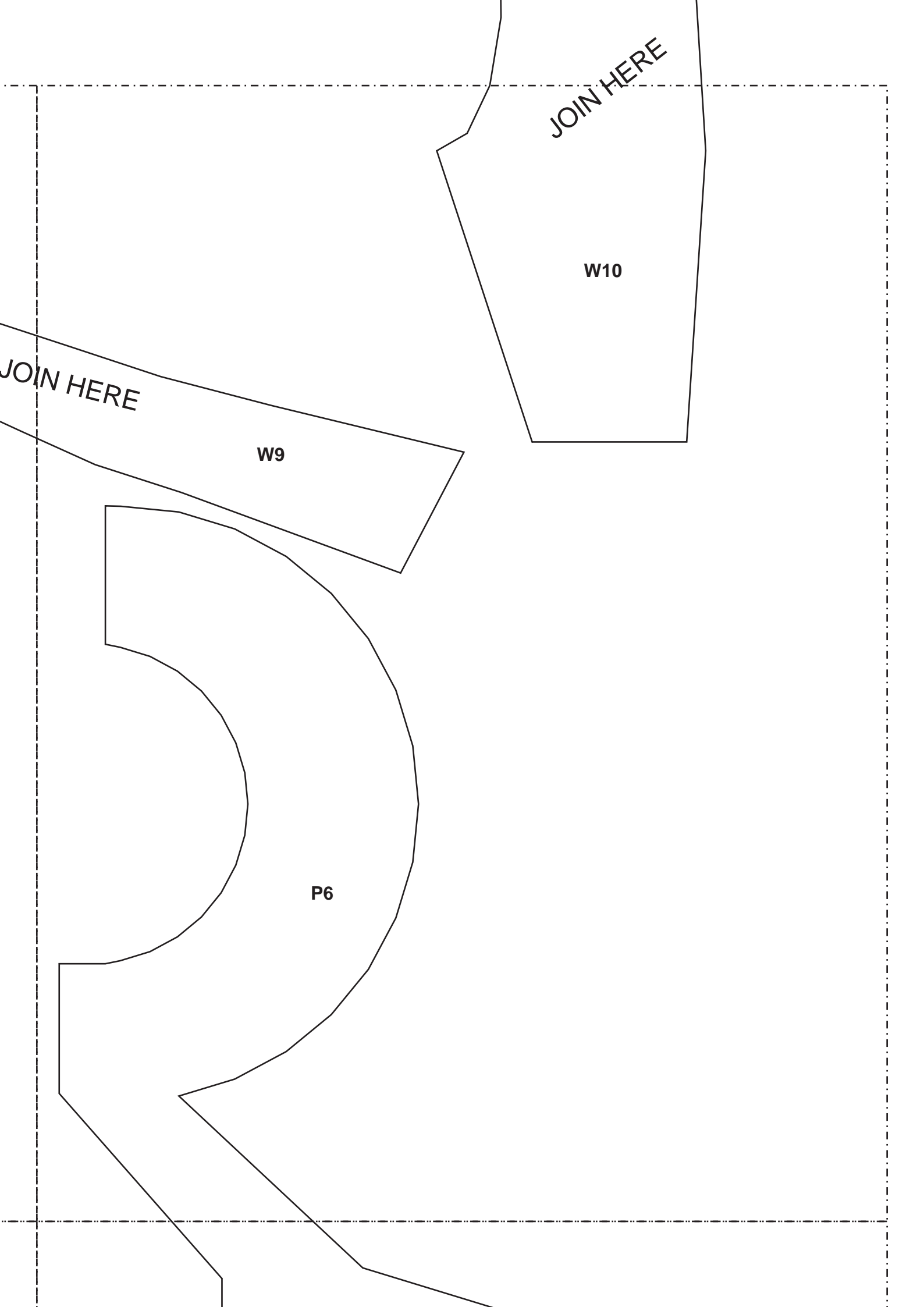



**P6**  
EDF MOUNTING  
PLYWOOD 3MM  
1X

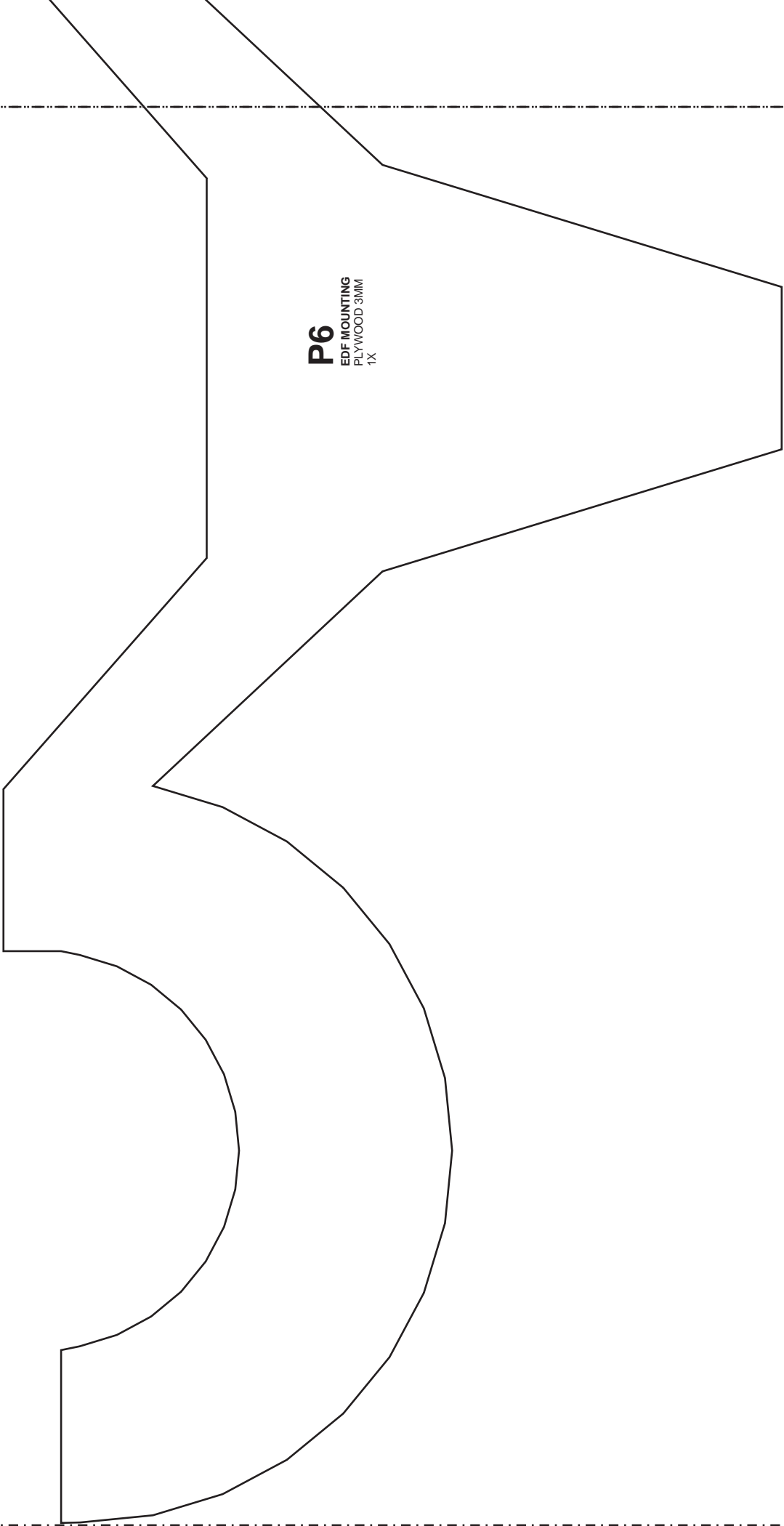

**E1**  
ENGINE NACELLE  
POLYFOAM/  
DEPRON 5MM  
2X

JOIN HERE

JOIN HERE

E1

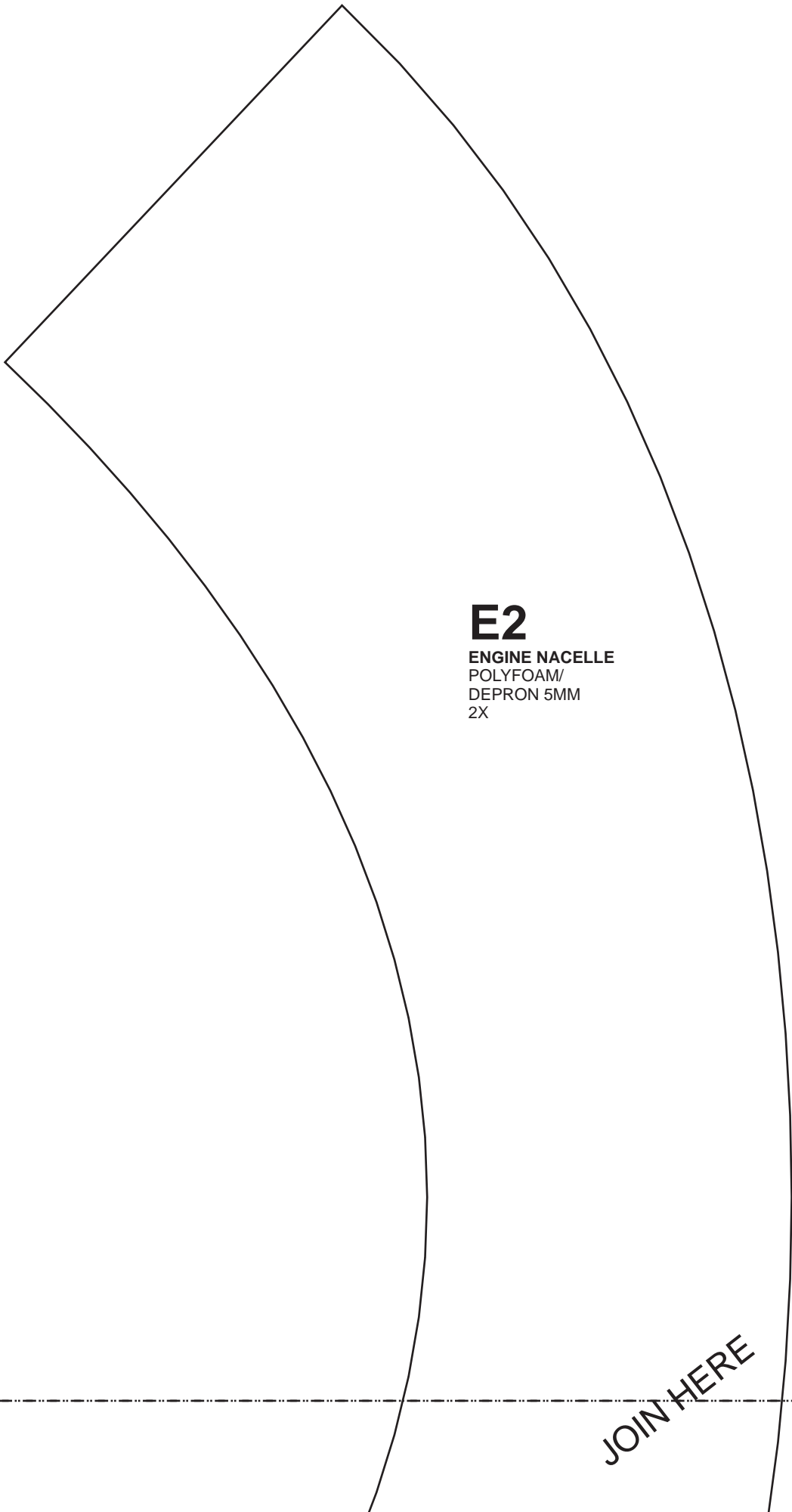

# E2

ENGINE NACELLE  
POLYFOAM/  
DEPRON 5MM  
2X

JOIN HERE

JOIN HERE

E2

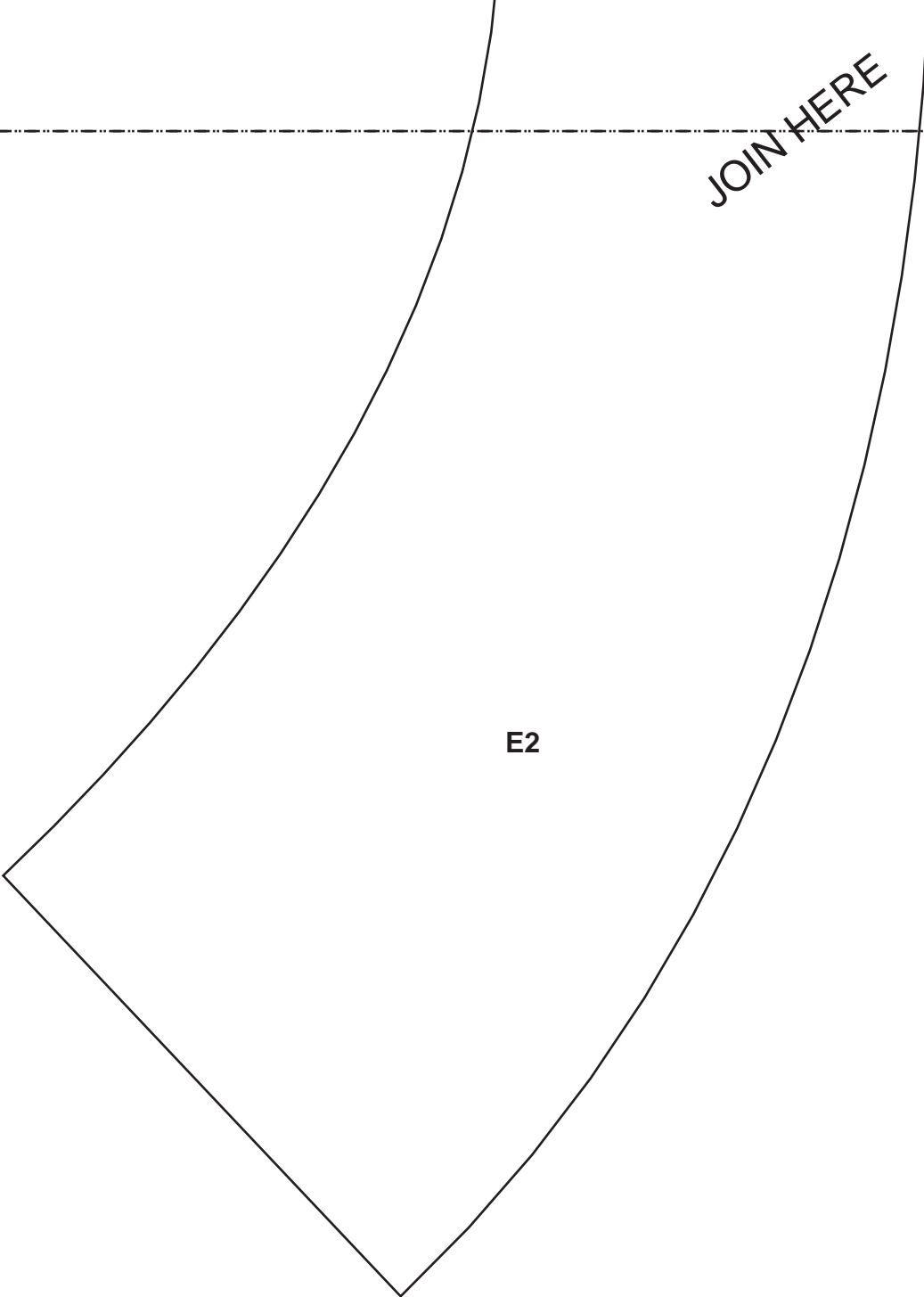

**E3**

**ENGINE NACELLE**  
POLYFOAM/  
DEPRON 5MM  
2X

JOIN HERE

**E4**

**ENGINE NACELLE**  
POLYFOAM/  
DEPRON 5MM  
2X

**E5**

**ENGINE NACELLE**  
POLYFOAM/  
DEPRON 5MM  
4X

JOIN HERE

JOIN HERE

E3

E4A

JOIN HE



JOIN HERE

E4

JOIN HERE

E4A

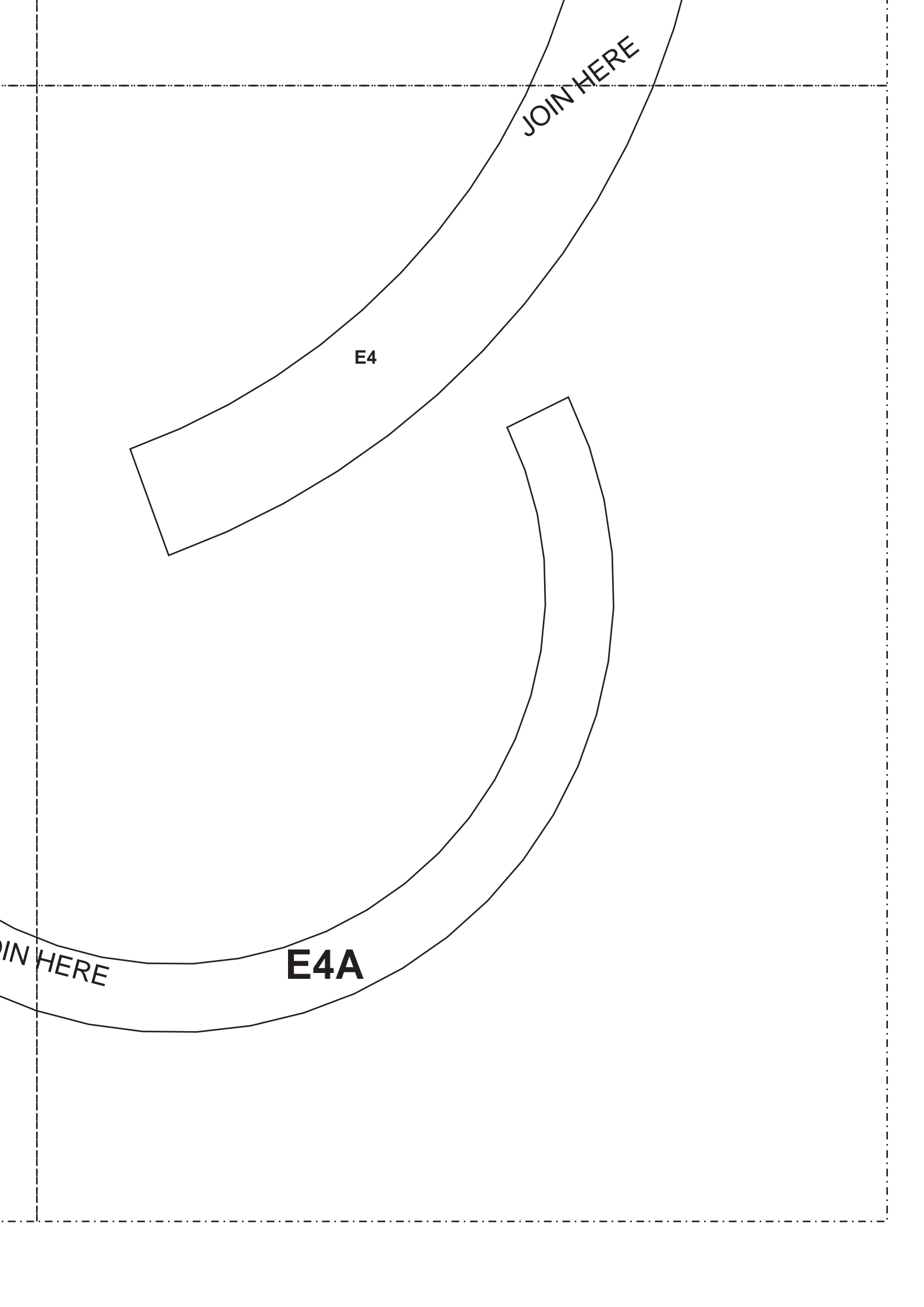

**E7**

ENGINE NACELLE  
POLYFOAM/  
DEPRON 3MM  
2X

**G7A**

TEMPLATE

JOIN HERE

JOIN HERE

**E7**

**E6**

**ENGINE NACELLE**  
POLYFOAM/  
DEPRON 3MM  
2X

JOIN HERE

JOIN HERE

E6

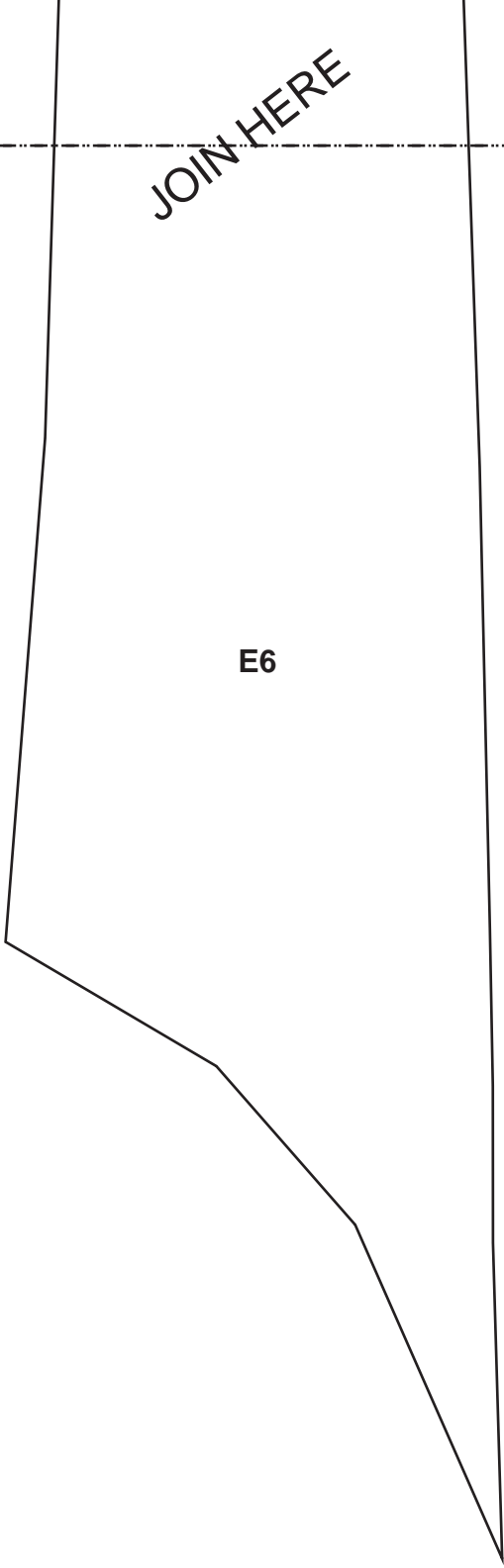

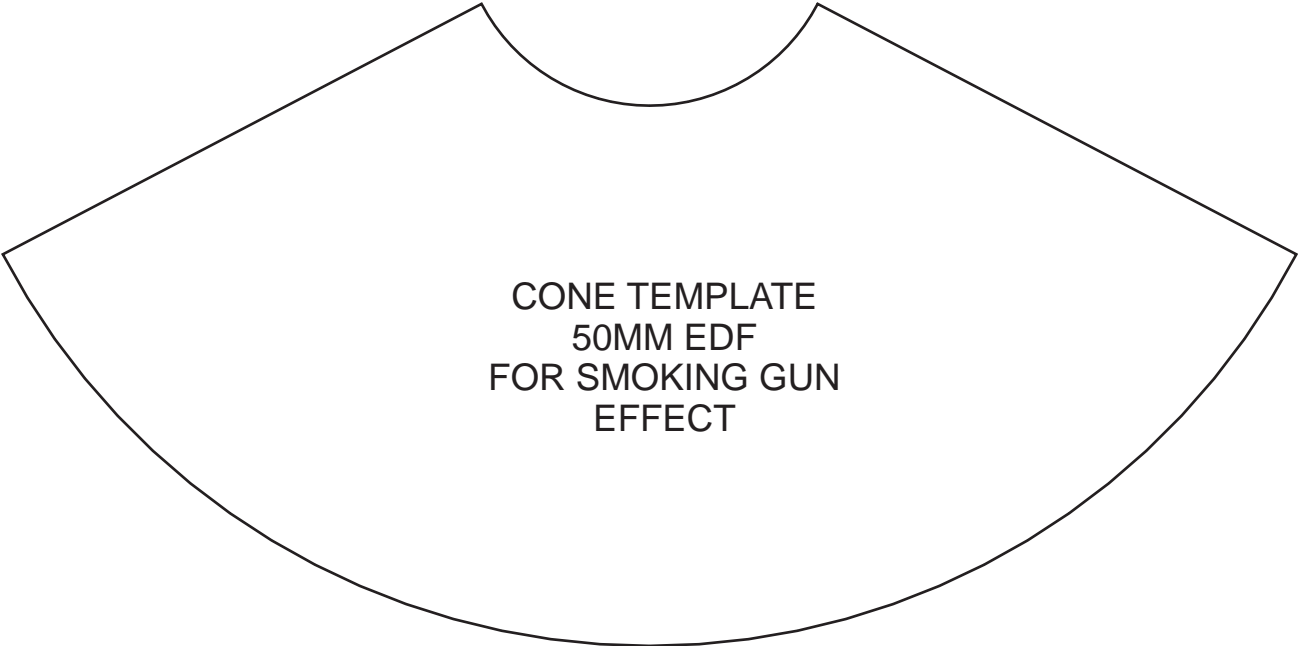

CONE TEMPLATE  
50MM EDF  
FOR SMOKING GUN  
EFFECT

THRUST TUBE



# E8

AIR INTAKE  
MICA PLASTIC 0.3mm/  
PAPER CARD  
2X

JOIN HERE

JOIN HERE

E8