



Model : 21/2021



# T-45 Goshawk

800mm

## Specs :

1. Wingspan 800mm / 31.5 inches
2. Flying weight : 850 grams/ 30 oz
3. Wing loading : 68.5 gram/dm<sup>2</sup> - 22.5 oz/sq.ft.
4. Wing cube loading : 19.5
5. Wing Area : 12.4 dm<sup>2</sup> / 192 sq.in.
6. CG : 11.8 cm from LE

## Electronics

- Tested with 2826 2200kv brushless motor with 6X4 propeller
- 2212 motor/ drone race motor
- 40A ESC
- Battery Lipo 3S 2200mah / 1300mah
- 4 plastic gear 9 gram servos (micro servo)

## Materials :

1. 5mm Depron/ Polyfoam
2. 3mm Plywood / PVC foam board
3. 0.5mm Mica Plastic
4. hot glue, UHU glue, CA glue
5. packing tape/ laminating film

## Build Instructions :

1. [paper-replika.com](http://paper-replika.com)
2. youtube channel : Julius Perdana

**F1**

**FUSELAGE**  
POLYFOAM/ DEPRON 5MM  
2X MIRRORED

**F2**

**FUSELAGE**  
POLYFOAM/ DEPRON 5MM

JOIN HERE

JOIN HERE

JOIN HERE

JOIN HERE

F1

F2

JOIN HERE

JOIN HERE

JOIN HERE

JOIN HERE

F1

F2



JOIN HERE

JOIN HERE

JOIN HERE

F1

JOIN HERE

F2

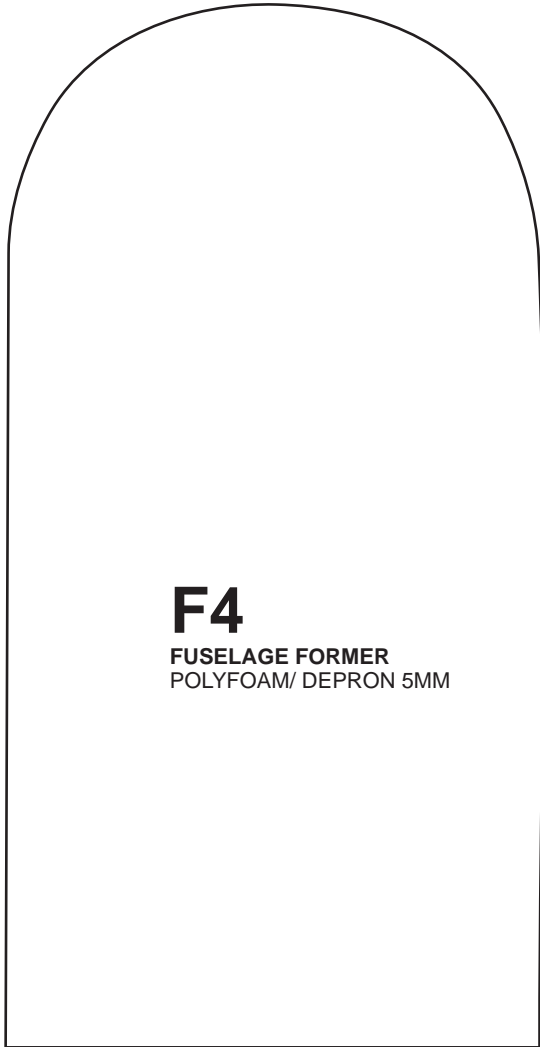

**F4**  
FUSELAGE FORMER  
POLYFOAM/ DEPRON 5MM

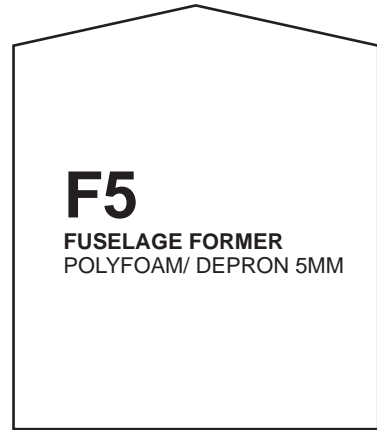

**F5**  
FUSELAGE FORMER  
POLYFOAM/ DEPRON 5MM

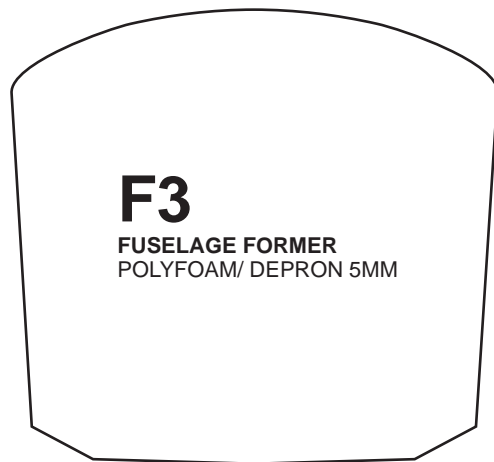

**F3**  
FUSELAGE FORMER  
POLYFOAM/ DEPRON 5MM

**F7**

FUSELAGE  
POLYFOAM/ DEPRON 5MM



**F6**

FUSELAGE  
POLYFOAM/ DEPRON 5MM

**F9**

NOSE CONE  
POLYFOAM/ DEPRON 5MM  
14X

JOIN HERE

JOIN HERE

F7

**T1**

NOSE CONE  
CARVE GUIDE

**F8**

FUSELAGE  
POLYFOAM/ DEPRON 5MM

**S2**

VER-STAB  
POLYFOAM/  
DEPRON 5MM

JOIN HERE

**F11**

LG  
DEPRON/ POLYFOAM 5MM

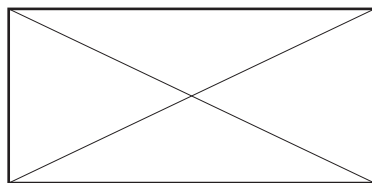



**S1**

**HOR-STAB**  
POLYFOAM/ DEPRON 5MM  
2X MIRRORED

JOIN HERE

**F10** **LG**  
PVC FOAM BOARD 3MM  
3X



# W1

WING BASE  
POLYFOAM/ DEPRON 5MM  
2X MIRRORED

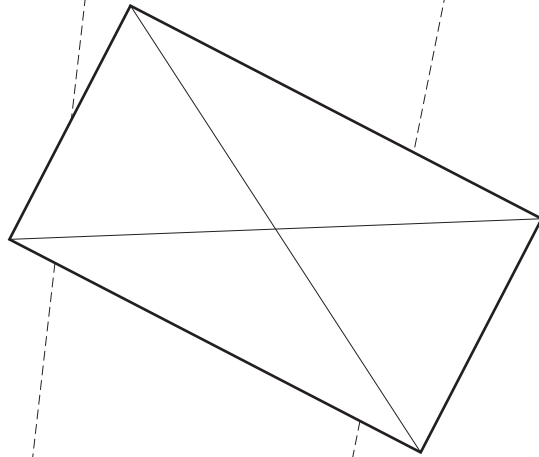

JOIN HERE

JOIN HERE

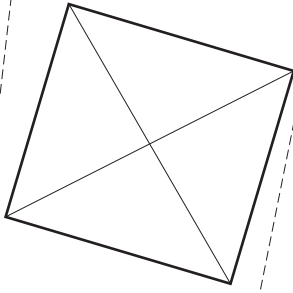

W1

AIRFOIL FORMER  
POLYFOAM/ DEPRON 5MM  
2X

W2

JOIN HERE

**W4**

WING SPAR  
POLYFOAM/ DEPRON 5MM  
2X

JOIN HERE

**W3**

WING SPAR  
POLYFOAM/ DEPRON 5MM  
2X

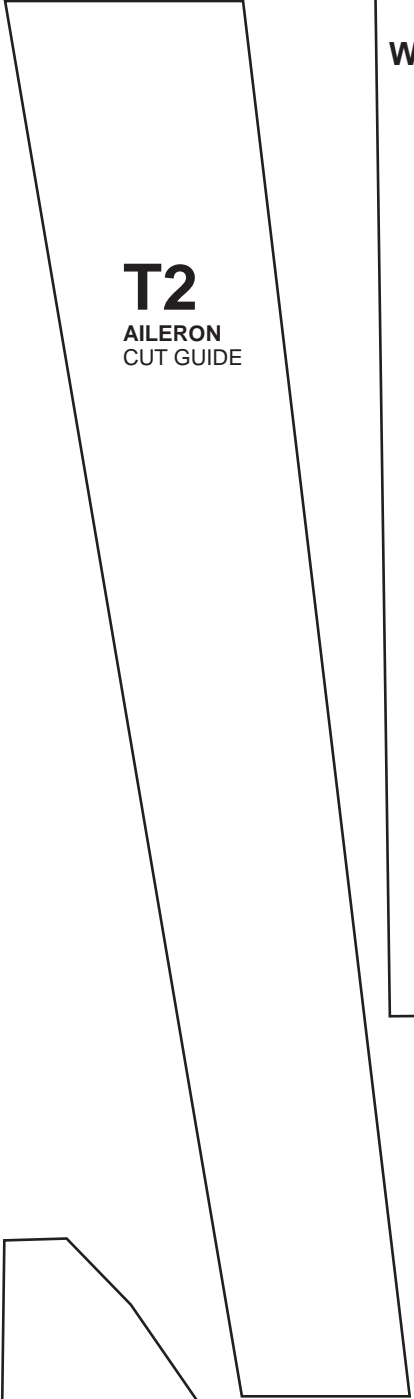

**T2**  
AILERON  
CUT GUIDE

JOIN HERE  
W4

JOIN HERE  
W3

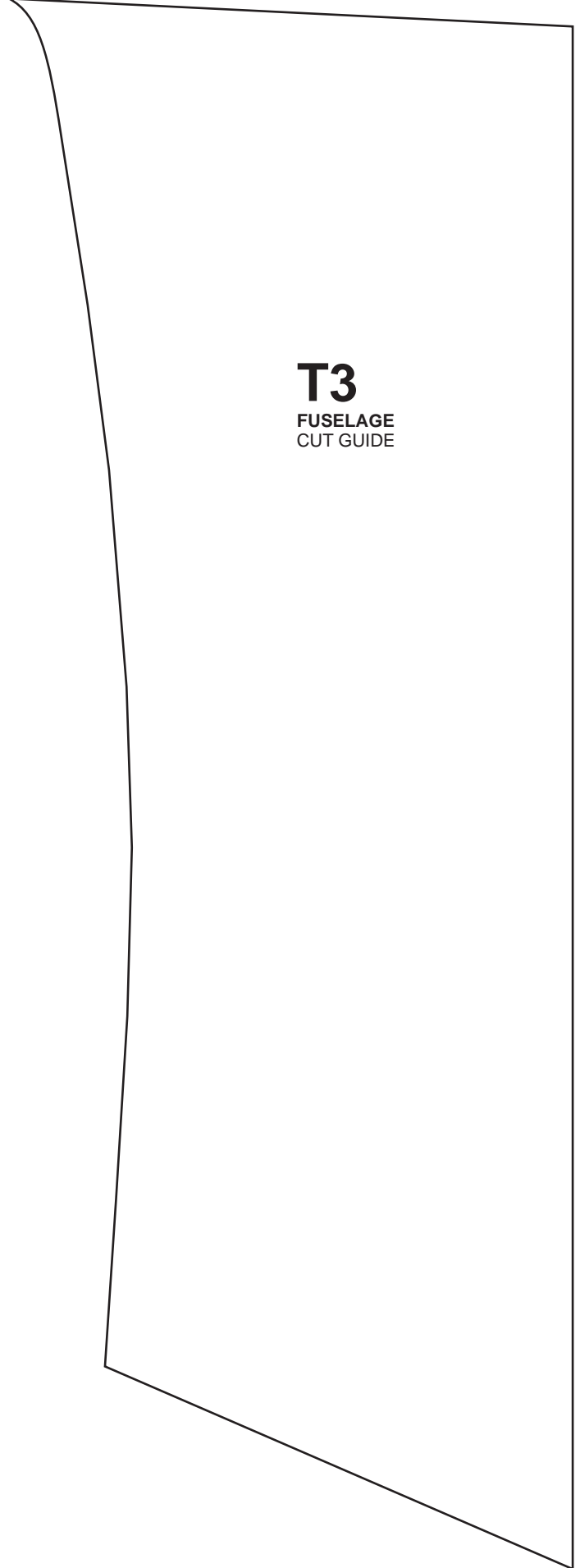

**T3**  
FUSELAGE  
CUT GUIDE



**W7**  
BELLY FIN  
MICA PLASTIC  
0.5 MM  
2X

# F16

COCKPIT  
POLYFOAM/ DEPRON 5MM

# W5

TOP WING  
POLYFOAM/ DEPRON 5MM  
2X MIRRORED

CG = 11.8cm

JOIN HERE

JOIN HERE

JOIN HERE

W5

**F14**

AIR INTAKE  
POLYFOAM/ DEPRON 5MM  
2X MIRRORED

**F13**

AIR INTAKE  
POLYFOAM/ DEPRON 5MM  
2X MIRRORED

**F12**

AIR INTAKE  
POLYFOAM/ DEPRON 5MM  
2X MIRRORED

**F11**

AIR INTAKE  
POLYFOAM/ DEPRON 5MM  
2X MIRRORED

JOIN HERE

W5

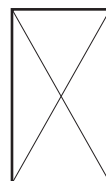

**F12**  
SERVO PLATFORM  
PVC FOAM BOARD  
3MM



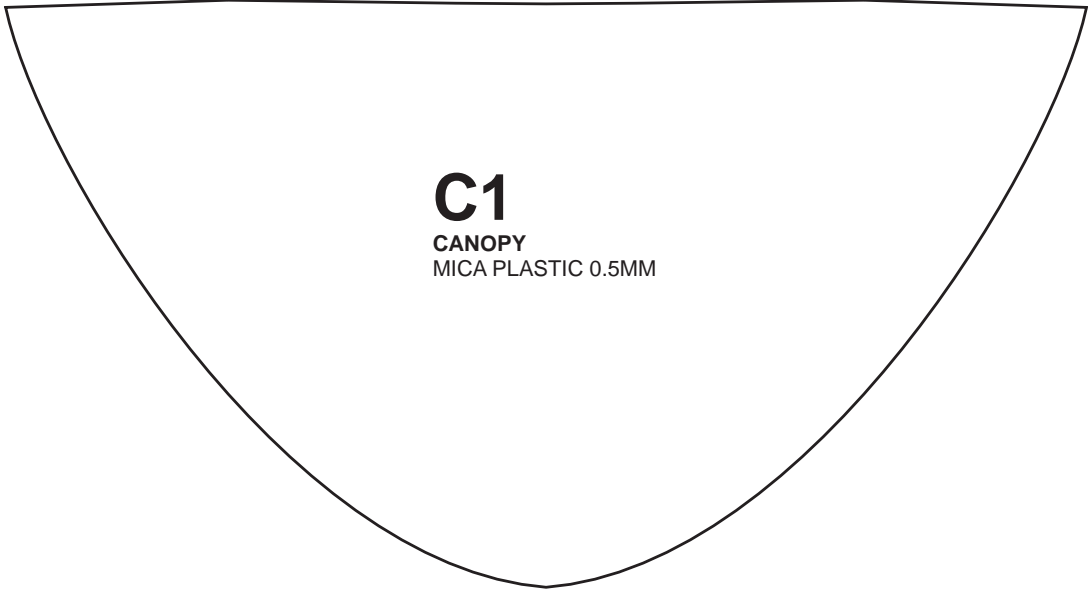
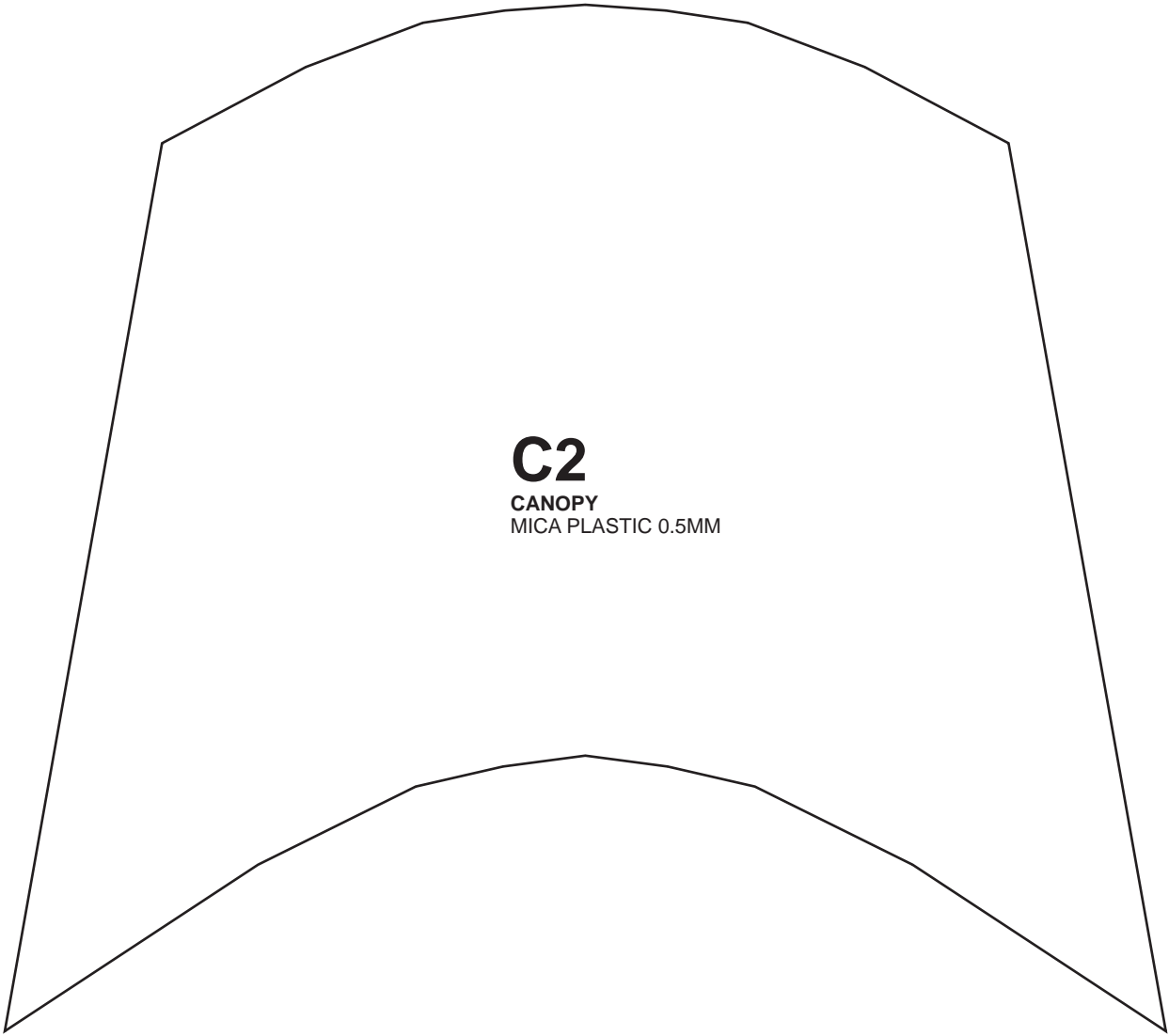

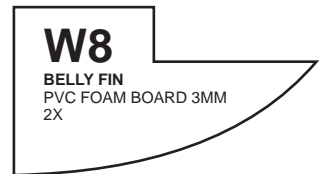
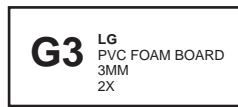
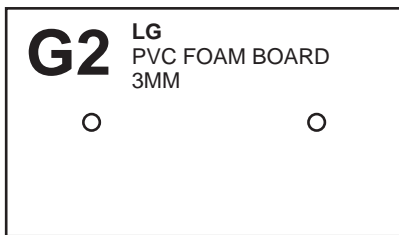
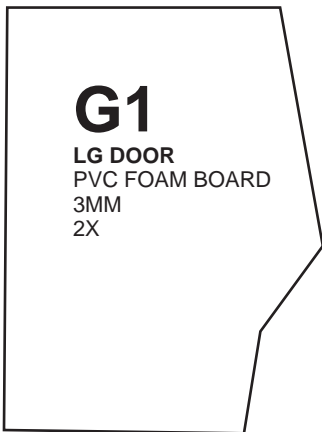
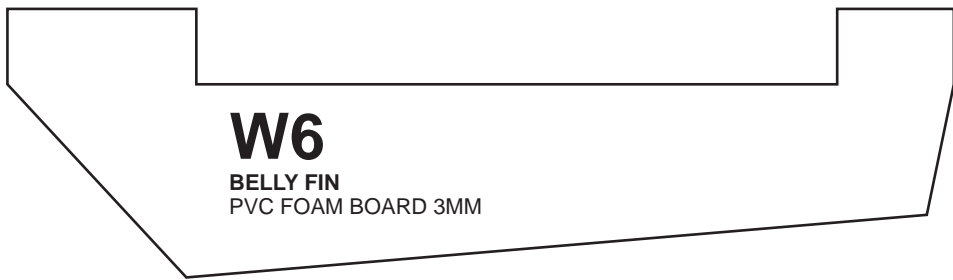
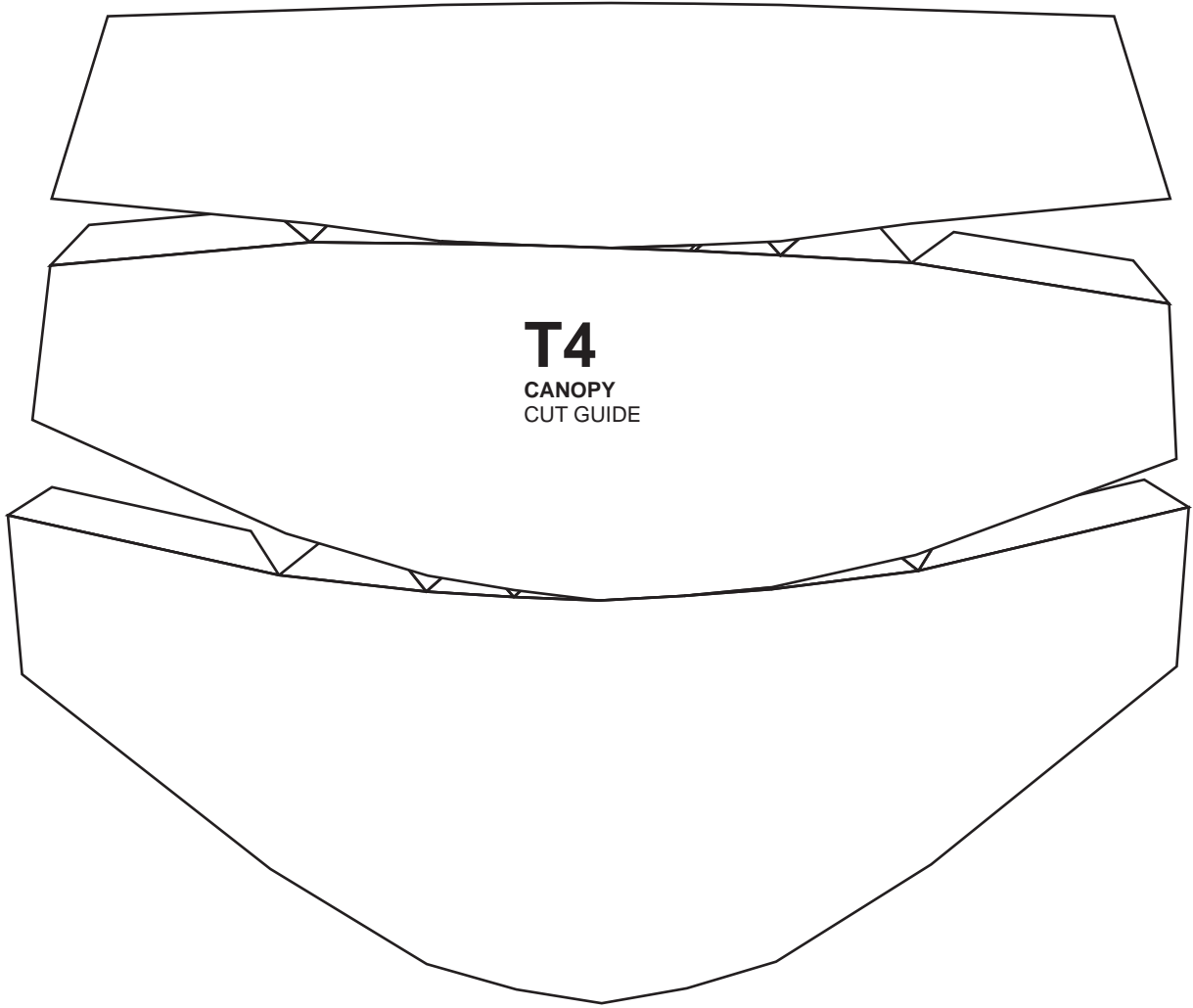

## FRONT LANDING GEAR

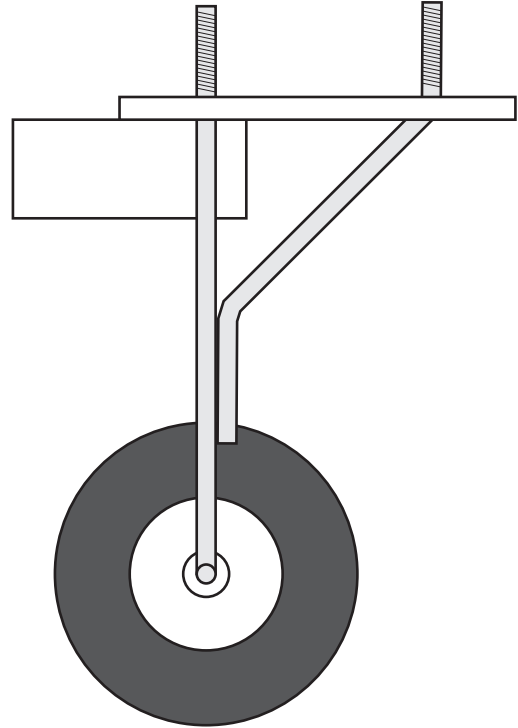
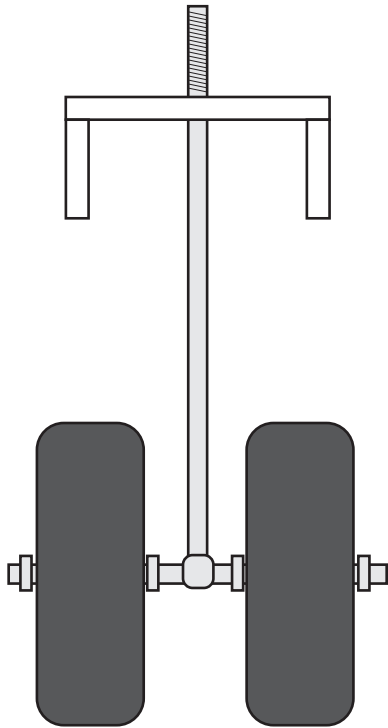

## MAIN LANDING GEAR (L/R)

