

Model : 36/2022

## Cartoon A6M Zero

1000mm

- Specs :**
- 1. Wingspan : 1000 mm / 39.4 inches
  - 2. Flying weight : 1005 grams/ 2.2 lbs/ 35.4 oz
  - 3. Wing loading : 38.3 gram/cm<sup>2</sup> - 12.6 oz/sq.ft.
  - 4. Wing cube loading : 7.5
  - 5. Wing Area : 26.22 dm<sup>2</sup> / 406 sq.in.
  - 6. CG : 7.75 cm / 3 inch from L.E. (leading edge on root chord)
- Materials :**
- 1. 5mm + 3mm Foamboard/ Depron/ Polyfoam
  - 2. 3mm Plywood
  - 3. hot glue, UHU glue, CA glue
  - 4. white packing tapes
- Electronics (Pusher)**
- DYN 2536 120kv
  - 40A ESC
  - Battery Lipo 3S 2200mah
  - 4 x 9 gram servos (micro servo)
  - 11x6x3 propeller (3 blades) or 12x6 propeller (2 blades)
  - 30mm, 2 x 100mm foam wheels
- Build Instructions :**
- 1. paper-repika.com
  - 2. youtube channel : Julius Perdana

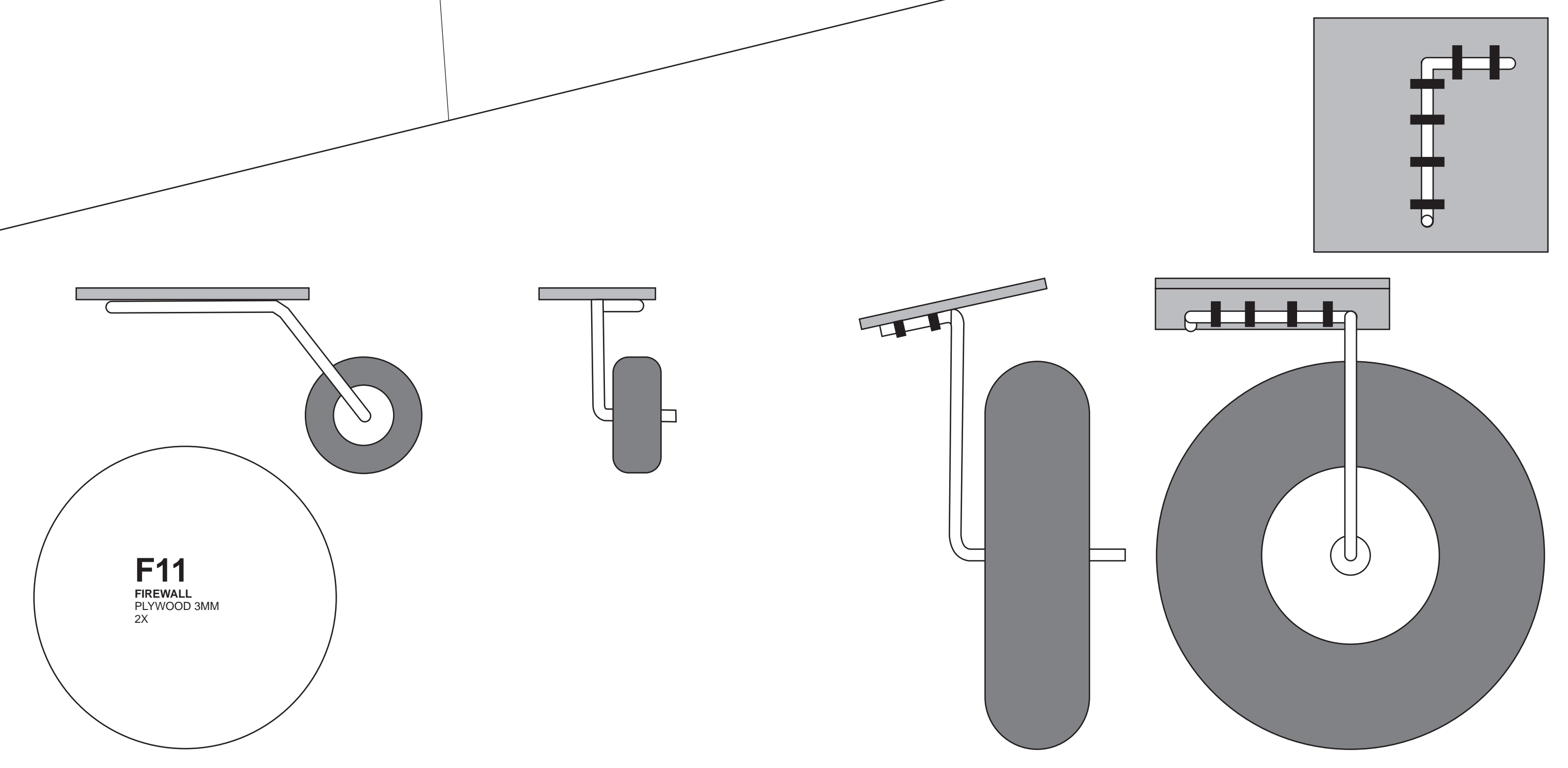
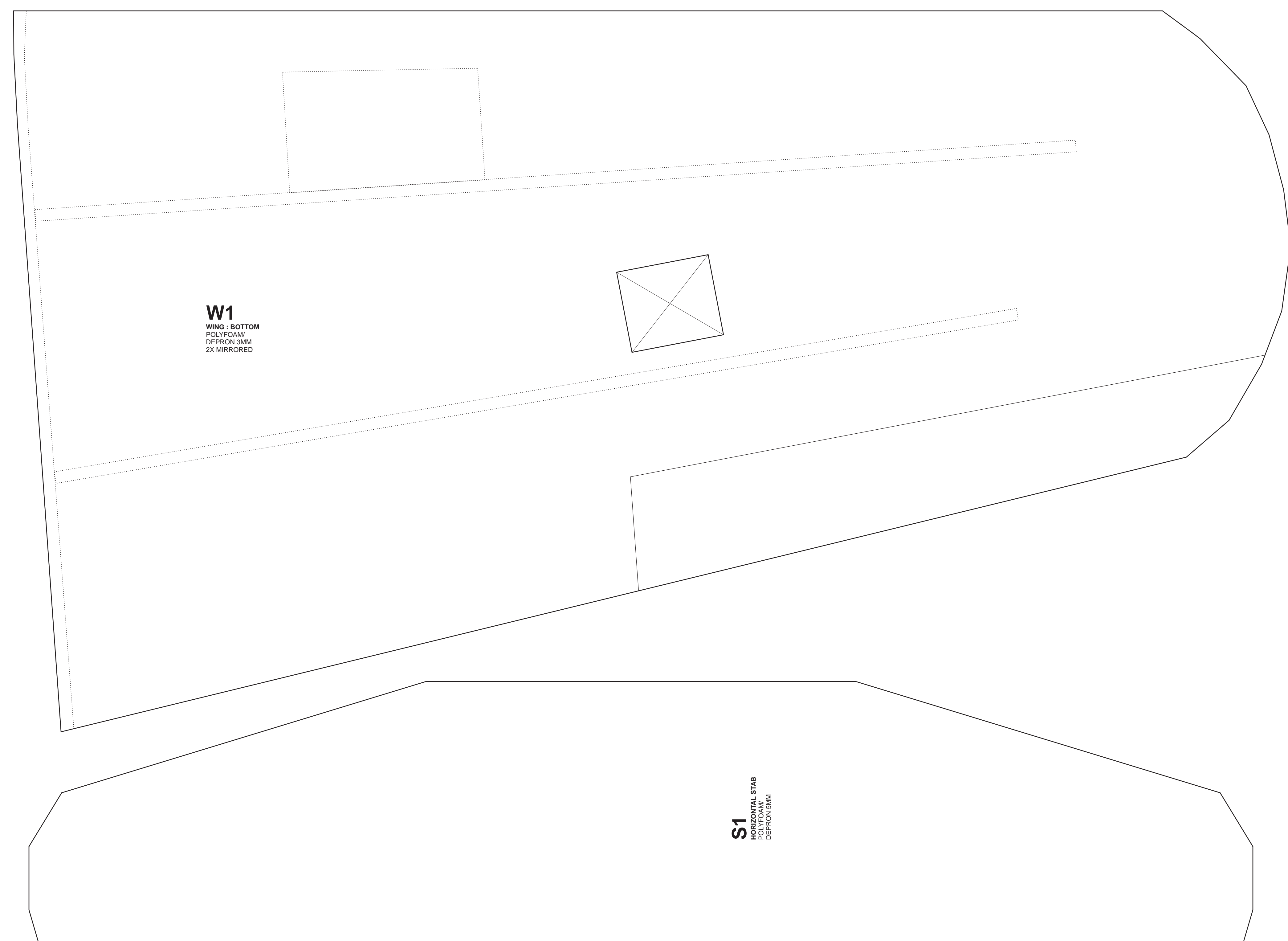
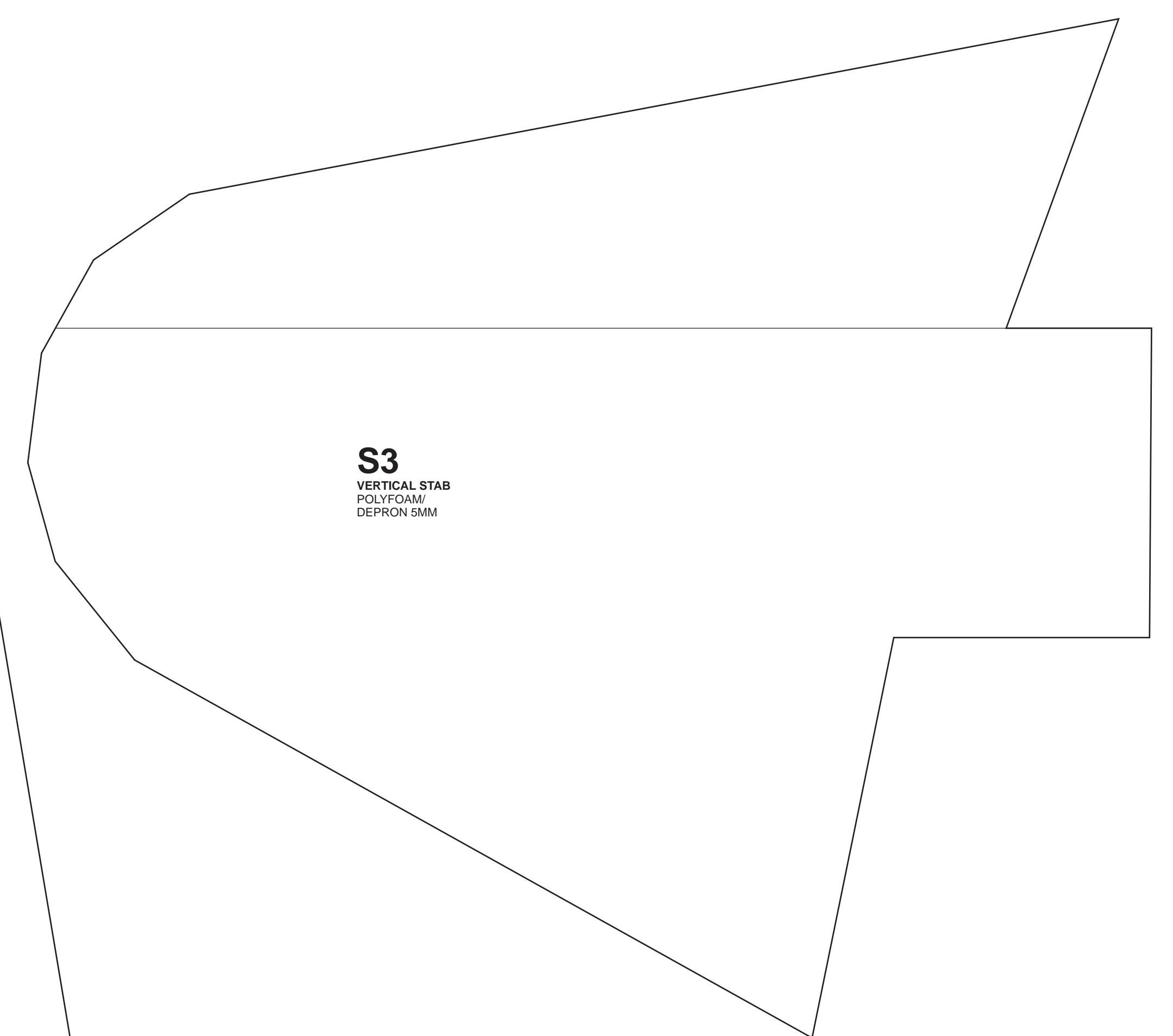
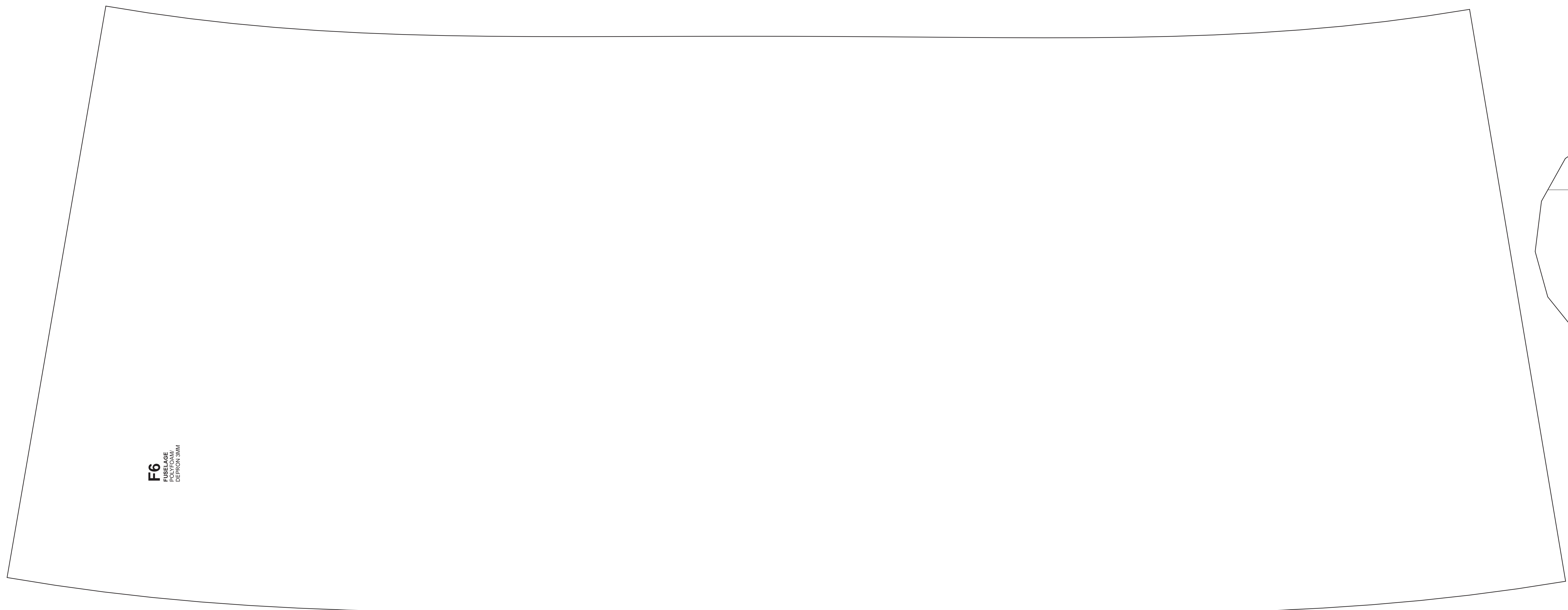

**S1**  
HORIZONTAL STAB  
POLYFOAM  
DEPRON 3MM